

RA708

Ruggedised Telephone



Reliability, Durability.
Weather & Vandal
Resistant.



DAC's RA708 Telephone – highly corrosion resistant & weatherproof cast aluminium case, providing excellent resistance to wear, even in the most arduous environments.

Utilising DAC's unique TUFF Handset, the RA708 telephone is the most robust ruggedised telephone in railway trackside applications.

Telephone failure's lead to train delays, incurring significant cost to Network Rail & Train Operating Companies (TOC's). It is estimated there are 8 million train delay minutes annually, many of which are related to faulty trackside equipment. Telephone reliability is Paramount.

A safety critical railway infrastructure component.

DAC's RA708 Telephone Engineering & Development

The RA708 Ruggedised Telephone has been established for over 30 years and still today, DAC are continually evolving their products quality and capabilities.

- ✓ Weather & Vandal Resistant
- ✓ 30 Years of Product Development
- ✓ GSM & GSMR
- ✓ VOIP & Analogue
- ✓ Renewable Power Sources
- ✓ Audibility Test
- ✓ Network Rail & High Speed Approved

For more information, please get in touch: sales@daclimited.co.uk

RA708 Ruggedised Telephone

Network Rail – Independently Verified History of Proven Reliability

The following overviews of two separate Network Rail investigations and tests conducted independently, verify the suitability and reliability of DAC's RA708 crossing and trackside telephone.



Investigation a) Network Rail Ruggedised Telephone Reliability

2 X trial runs at 30 of the worst performing crossings where telephones were installed. Trial 1 with competitor Telephone. Trial 2 with DAC RA708 Telephone.

The results concluded that DAC's RA708 Telephone was 300% more reliable than the competitor telephone, across the 12-month test period.

Investigation b) Network Rail Ruggedised Telephone Performance

Network Rail conducted tests to determine why the DAC RA708 telephone performed better over longer distances than other lineside telephones in use.

Investigation Findings:

- DAC RA708 telephone = Sound quality held to 12km
- Competitor telephone = Sound quality loss at 6km

DAC's RA708 telephone outperformed the competitor telephone by 100%



(Network Rail – Annual Report 2014 pp.146 – 147)

“Crossing telephone failures account for 15 per cent of the delay incidents [...] The preferred telephone model (DAC 708) was selected following trials and has now been adopted as the phone of choice for installing and using at level crossings. This new phone has proved to be more reliable and will be used for future projects and renewals.”

RA708 Ruggedised Telephone

Available with Magnet or NR No. 1 Lock

RA708 with No. 1 Lock

Available on any variation of RA708 Ruggedised Telephone.

Designed for applications where Network Rail are currently utilising Anti-Vandal Housings to protect telephones from interference. A cost effective and easy to install solution, negating the need to install expensive and labour intensive Anti Vandal Housings.

Network Rail Approved – PADS Number 087-000651



RA708 With Magnet

Available on any variation of RA708 Ruggedised Telephone.

Designed for applications where the telephone door might be opened due to passing vehicles, for example in tunnels where pressure cycles are created by High Speed trains.

Network Rail & High Speed (HS1) Approved reference CT2005096

Technical Specification

Speech/ Network Interface:
VOIP, GSM, GSM-R, Analogue

Ringing:
Frequency modulated, piezo transducer, cadence as per incoming ringing. REN 1.0, speaker.

Power Supply:
Line powered [PSTN], POE [VoIP], DC [VoIP, GSM], battery pack [GSM], solar & wind power [GSM].

Time out:
Programmable

Temperature:
Operating: -30° C to +60° C
Storing: -40° C to +70° C

Relative Humidity:
Up to 95% (non-condensing)

Casing Material:
Robust cast aluminium.

Weight:
3.5kg

Colours:
Standard yellow or grey durable powder coat.
[custom colours available].

Safety:
Manufactured to BS EN 60950
EN55022:1998 (EMC - Emissions)
EN50121-4:2006 (EMC compatibility – railway applications)
ITU-T K21 (Resistibility of telecommunications equipment to over voltages and over-current)

Protection:
Dust and liquids – IP65

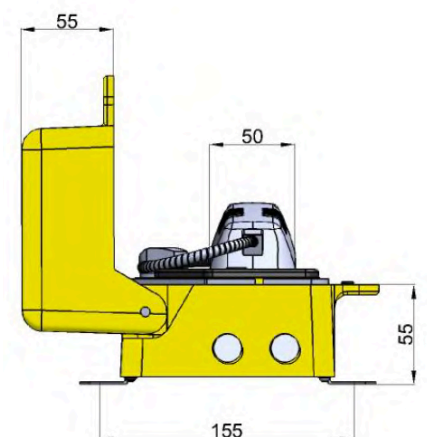
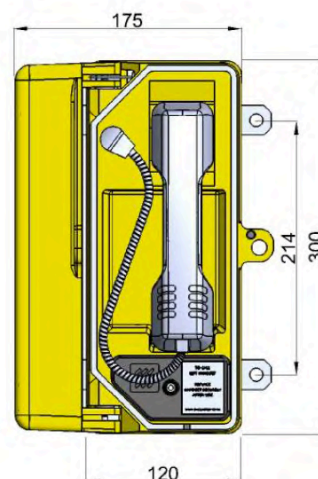

RA708 Ruggedised Telephone Accessories

PSTN Post

Lightweight design for easier installation. Deburred and powder coated for a smooth corrosion resistant finish, with soft edges for safer handling.

Network Rail Approved – PADS Numbers, see Table 1

PADS Number	Item Description
0087/001133	PSTN Mounting Post Galvanised
0087/001350	PSTN Mounting Post Grey
0087/001351	PSTN Mounting Post Yellow



Label Holder

Network Rail Approved – PADS Number 087/100821

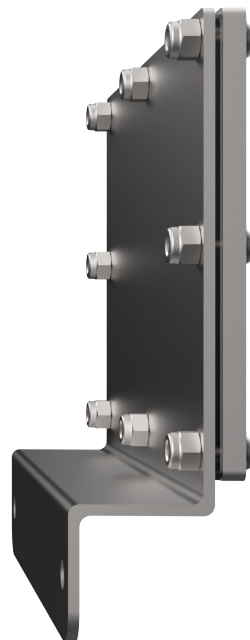

The DAC Label Holder provides external (to telephone) protection for location labels mounted on UWC telephones in order to provide the user with the necessary information when contacting the signalman.

Suitable for all UWC telephones, simple installation, extremely robust.



DAC Limited
T: +44(0) 1282 447000
F: +44(0) 8452801915
E: sales@daclimited.co.uk
www.daclimited.co.uk

