

**PADS No. 087/000665**  
**Weatherproof Telephone RA711-CB**

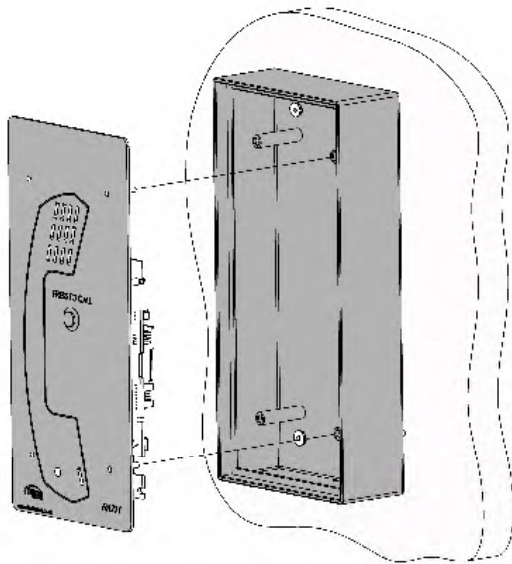

- RA711 Series
- Network Rail acceptance
- CB (Hot Dial) operation
- Auto Clear Down
- LED Indicator for off-hook
- Raised button in line with DDA directives
- All weather protection
- Simple installation
- Fast-fit terminal connection
- Various mounting options
- REN-1 rating
- Line powered
- CE compliant

Mounting options:



**Top of pole mounting:**  
Top of Pole bracket available from DAC:  
**PADS No. 087/000667**

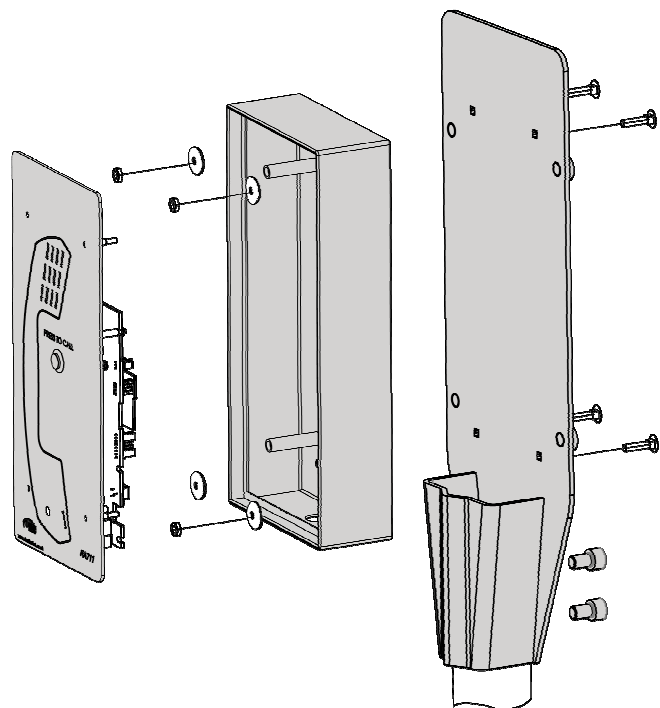

**Wall mounting:**  
On Wall box available from DAC:  
**Part No. RA711-NR**  
**PADS No. 087/000666**

# TECHNICAL SPECIFICATION

## Speech/ Network Interface:

Voice switched (VOX) semi duplex operation.

## Ringing:

Through internal speaker, REN 1,

## Power Supply:

Line powered, 15mA min.

## Call Cleardown/Time out:

Adjustable timer from 1 to 10 minutes or off.  
Auto cleardown function on tone detection from the line

## Temperature:

Operating: -30° C to +60° C  
Storing: -40° C to +70° C

## Relative Humidity:

Up to 95% (non-condensing)

## Keypad/Buttons:

Heavy duty metal keypad and buttons, Vandal resistant.

## Material:

Robust high grade Stainless Steel

## Programming:

Using on board keypad and externally connected security keypad

## Weight:

1.8kg

## Safety:

Manufactured to BS EN 60950

## Protection:

Dust and Liquids to IP55

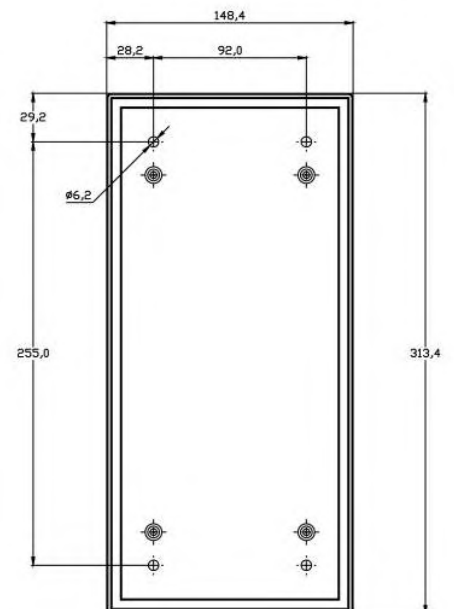
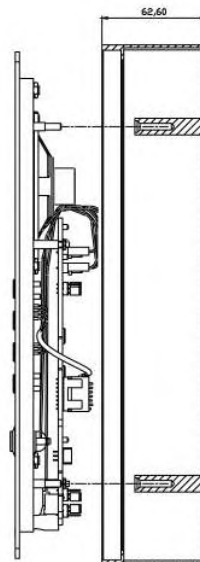
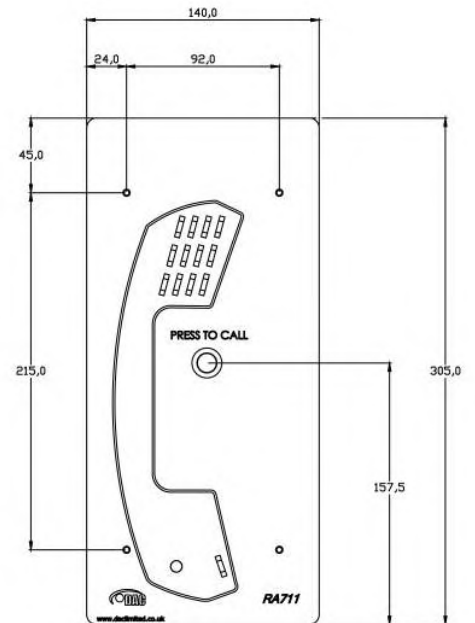
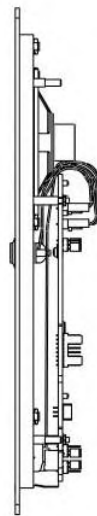

DAC Limited  
Union Mill, Watt Street,  
Sabden, United Kingdom  
BB7 9ED

Tel. +44 (0) 1282 447000, Fax: +44 (0) 845 280 1915  
[www.daclimited.co.uk](http://www.daclimited.co.uk)