

SUBJECT **300 BAUD DATA MODEM TYPE 2B**

Your modem type 2B has been tested and configured prior to despatch. The modem is built to an exceptionally high standard and will give many years of continuous service. No attempt should be made to modify or alter internal straps without prior consultation with our technical staff.

The modem 2B is capable of half or full duplex data communication at any speed up to 300 baud via a standard single pair 600 ohm type communications line. The modem tone frequencies, and input output connections conform to the European CCITT standard.

Line and data connections.

Data connections to and from the computer or terminal equipment are made via a standard 25 way 'D' type socket with RS232 specification voltage levels, see fig. 1.

Connections to the communications line and auto answer strapping are made via the 16 way terminal block situated under the rear cover plate. The communications line is connected to terminals 11 and 12.

For auto answer use, link terminals 13 and 15, connect a 1.00 mf 250v non polarised capacitor between terminals 6 and 7, and a thermistor type 1A between terminals 5 and 8. After installation of the auto answer modification the RING INDICATOR output (pin 22 on 25 way 'D' socket) will go HIGH in unison with the ringing voltage detected from the communications line, giving an indication to the computer that an incoming call is present, and if so desired, may be answered by taking pin 20 HIGH. An auto answer mod kit is available at £2.50 plus VAT.

Modem use.

All functions of the modem 2B can be controlled via, either pin 20 on the 25 way 'D' connector, or the two brown test jacks situated under the hinged front panel. It is important to note that the two test jacks OVERRIDE functions from the interface connections.

For normal use ensure that the brown jack plugs on the front panel are in the "AUTO" and "DATA" positions. Dial the remote computer number i.e. DISTEL on 01-679 1888, establish your connection on hearing the high pitched answer tone, and within 15 seconds either take pin 20 on the 25 way 'D' type interface socket HIGH, OR move the test jack plug on the control module to the "CALL" position. Either of these operations will loop and hold the line, and turn on the modem carrier tone, enabling you to replace your handset, and eliminate any extraneous room noise.

Always remember to return the jack to the 'AUTO' position or remove the signal on pin 20 after you have finished with a data call, otherwise your line will be held as long as either of these signals are present.

Other signals are available on the 25 way 'D' connector such as CARRIER DETECT. This signal is HIGH as long as a carrier tone from a remote computer is present. Via software on your CPU, loss of this signal could tell your computer to abort the call, stop a program and reset the modem, thus returning the line to normal.

For an excellent book on modems and data communications we would recommend "Modems in Data Communications" by P.R.D. Scott available from Display Electronics at £16.00 plus carriage.

NOTE - Display Electronics do not accept any responsibility actual or implied as to use of modems or loss or damage in any form whatsoever resulting from use of modems. Permission to connect the 2 wires from the modem to the 2 wires of a telephone line may be required.

CCITT Circuit Description	No	25 Way D Socket Pin No.
Transmitted Data	103	2
Received Data	104	3
Request to Send	105	4
Ready for Sending	106	5
Data Set Ready	107	6
Signal Common Return	102	7
Carrier Detect	109	8
Select Transmit Frequency	126	11
Connect Data Set to Line, or	108/1	
Data Terminal Ready	108/2	20
Ring Indicator	125	22

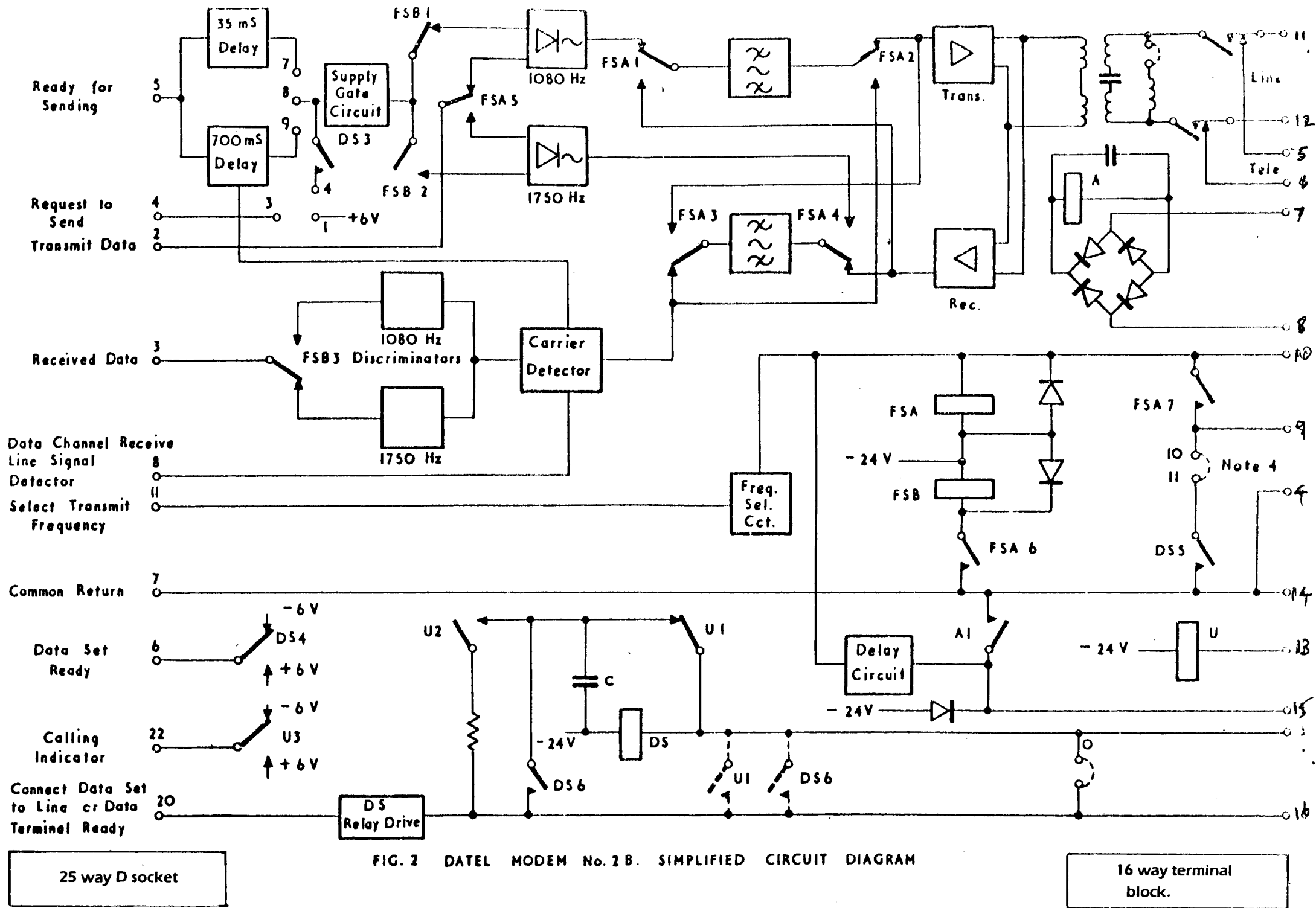

25 way D socket

16 way terminal block.