

## A NEW C.B. MICROTELEPHONE.

A. J. ALDRIDGE, E. J. BARNES, E. FOULGER,

**I**NTRODUCTION.—In August, 1927, the Research Section was asked by the Engineer-in-Chief to design a microtelephone which would be equal to any instrument of that type then available, and which would not infringe any existing patents.

Extensive tests of microtelephones from all sources had been carried on for many years, but the results were generally far inferior to those obtained with the fixed solid back trans-

mitter and Bell receiver of the P.O. standard pedestal telephone.

*General features of the proposed instrument.* The requirements which it was desired the instrument should meet were:—

*Electric and Acoustic.*—

(1) Sending efficiency should not be more than 1.4 d.b. worse than P.O. basic standard.



FIG. 1.—THE NEW C.B. MICROTELEPHONE.

(2) Receiving efficiency should not be more than 1 d.b. worse than Department's standard.

(3) Articulation should be 10%, or more, better than standard.

(4) Frying and packing should not be worse than on the No. 1 C.B. Transmitter.

(5) The instrument should be capable of use without serious change in efficiency when used in any practicable position.

(6) The instrument should not "howl" on a short local line.

These desiderata are rather severe, but it was considered advisable to work to them if possible.

be self-contained on the lines of the No. 1 transmitters, as this has been found in the past to be a good design.

(3) The mouthpiece should be hygienic and easily cleaned.

(4) The instrument should be robust, of pleasing appearance and not easily interfered with by the subscriber.

#### *Transmitter Design.*

A large number of model transmitters were made up, mainly by using parts of the No. 1 C.B. transmitter. The points which were



FIG. 2.—THE HAND-SET ASSEMBLY.

Several patterns of headgear type receivers giving good transmission efficiency were known and no difficulty was expected in adapting any of these for this purpose. Attention was therefore mainly concentrated upon the transmitter and the following mechanical points were kept in mind:—

- (1) Transmitter and Receiver should be of "inset" type for ease of replacement.
- (2) The granule chamber should preferably

chiefly kept in mind were means to enable the transmitter to work in any position, the reduction in the sharp resonance of the No. 1 Transmitter, and the improvement in efficiency by reduction of the weight of the moving parts.

The most satisfactory model consisted of a granule chamber made up in cylindrical form, the end away from the diaphragm being closed with a mica diaphragm and electrode, identical

with that in the No. 1 transmitter except that the excess brass present was very considerably cut down. This moveable electrode was connected with the diaphragm by means of an insulated bolt passing through the granule chamber. The other electrode was in the form of a gold-plated ring fixed about half-way down the chamber.

Satisfactory performance was obtained with transmitters of this type as regards maintenance of efficiency when used away from the vertical, but it was soon found that when the diaphragm was reduced to a size suitable for use in a micro-telephone the sending efficiency fell away seriously. This was remedied by the use of a coned diaphragm of thin aluminium with an annulus of thin surgical silk to reduce the stiffness. This diaphragm was later replaced by one consisting of two opposed cones, between which the annulus was clamped. This produced a more rigid piston and also eliminates the difficulty of attaching the annulus to the cone. The silk annulus was also later replaced with one of thin aluminium foil. The result is a stiff, piston type diaphragm, with a very flexible edge; the weight of the whole moving system is under two grammes as against 7.8 grammes for the No. 1 type transmitter.

*Shape of Handle.* The first handles made were of triangular section with rounded edges, the handle itself sweeping into a more or less hemispherical boss carrying the transmitter, and into a similar but smaller boss carrying the receiver. After considerable discussion, and the examination of various different experimental models, a shape was finally adopted which is very similar to that of the A.T. & T. Co's. instrument.

The length of the handle was based upon fresh measurements of a large number of heads, and is actually 5" between the centre of the ear-piece and the nearest point of the transmitter case. The inside of the mouthpiece is a nearly cylindrical tube with a bore of about  $1\frac{3}{8}$ ". The transmitter inset itself is provided with a perforated metal guard, the holes in which are out of line with the holes in the grid at the base of the mouthpiece, so that there is no possibility of objects being pushed on to the diaphragm. The plane of the opening of the mouthpiece is at an angle of about  $45^\circ$  with the line of the handle, so that a shorter handle is possible than would

otherwise be the case without causing the lips of a long-headed user to touch the instrument.

*Complete Test of 5 C.B. Microtelephones.* Six complete handles (somewhat different in shape from the final models) were made up in ebonite and fitted with transmitters and receivers. The receivers were of the Sterling Telephone 1A pattern and no special steps were taken at this time to ensure that they were the best obtainable. Five instruments were submitted to test, the other being kept apart for demonstration if required.

The following is a summary of the results obtained, each transmitter being tested in the handle by 20 speakers to obtain a reliable average. All tests were made on Standard C.B. 300-ohm local:—

Volume efficiency, head in normal position.	1.5 d.b. Worse than Standard.
Range between instruments	0.3 d.b. to 2.7 d.b. Worse than Standard.
Receiving efficiency	2.5 d.b. Worse than Standard.
Range	0.2 d.b. to 6.2 d.b. Worse than Standard.
Articulation	6% Better than Standard.
Range	8% Worse — 22% Better than Standard.
Naturalness (Ease of recognising a voice)	Errors reduced to 75% in comparison with No. 1 C.B.
Resistance	61 ohms.
Range	54-77 ohms.
Frying	Passes specification for No. 1 transmitter at any angle up to $45^\circ$ .

The "naturalness" test was made because it was felt the articulation figures did not fairly represent the improvement. It is well known that a receiver, for example, when used as a transmitter, is very articulate but the tone is

unnatural, being thin and reedy. The "naturalness" test was made by twelve observers, well-known to one another, each reading to each of the others a short passage. The observer was required to name the reader. It was found that on the average with the No. 1 transmitter 33% mistakes were made, whereas with the new transmitter 25% mistakes were made.

A microtelephone fitted with a good transmitter and a good receiver showed no tendency to "howl" on a 35-ohm local.

It will be seen that these transmitters are superior to the average supplies of No. 1 C.B. transmitters (last 3 sample batches were 2.4 d.b. worse than Standard) in both volume and articulation.

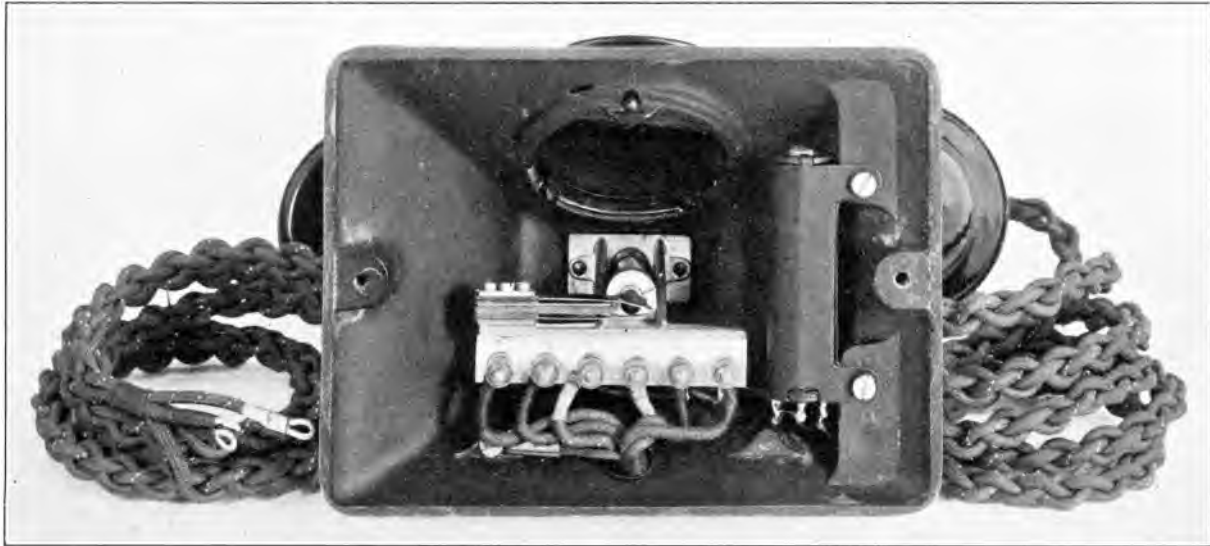

FIG. 3.—VIEW UNDER BASE OF CRADLE.

*Life Test.* Four of the transmitters were subjected to the usual life test of 30,000 opera-

tions and the following table gives the complete results after this:—

EFFICIENCY TESTS AFTER 30,000 OPERATIONS.

Transmitter No.	Head Vertical.			Head at 45°			Head Horizontal.		
	Effcy. d.b.	Resis.	Articulation	Effcy. d.b.	Resis.	Articulation	Effcy. d.b.	Resis.	Articulation
	11 Observers	Ohms		11 Observers	Ohms		3* Observers	Ohms	
B	0.4W	72	4% B	0.8B	104	8% B	1.9B	140	Not tested
C	0.3B	96	10% B	0.7B	113	7% B	0	159	16% B
D	0.6W	78	1% B	0.4B	117	10% B	3.6W	157	3% B
E	1.4W	71	6% B	1.0W	95	3% B	0.4B	184	4% B
Mean	0.5W	79	5% B	0.2B	107	7% B	0.3W	100	8% B

\* The results obtained with the three observers have been corrected to allow for the fact that they were not average.

The transmitters had thus somewhat improved in efficiency but the resistance had risen. This rise may be the cause of the improved efficiency.

Efficiency and articulation were well main-

tained, at any rate up to the 45° position. Tests were made in the 90° position as a matter of interest, but the position is only reached in practice with very considerable discomfort.

The resistance is high, particularly in posi-

tions away from the vertical position, but this latter is not of great importance in a micro-telephone for the reason that the transmitter is almost certain to be put into a vertical position before being put into the "use" position. This would cause the supervisory signals to be operated and these will then remain operated for any position of the transmitter. Steps were, however, taken to reduce the resistance.

FREQUENCY CHARACTERISTICS OF C.B. TRANSMITTERS.

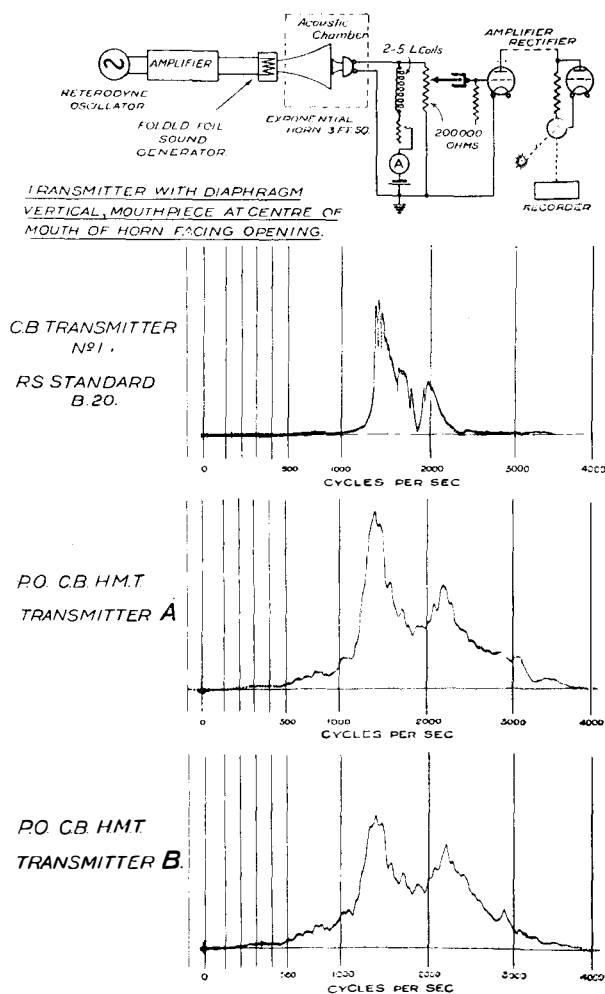

FIG. 4.

**Mechanical Test.** Three transmitters were taken from the handles and mounted in a wooden frame which could be raised one quarter of an inch and then dropped on to a block of wood.

The frame was dropped 50,000 times, and volume and resistance tests were then again made.

An average reduction in efficiency of 1.4 d.b. was obtained.

**Frequency Characteristics.** Frequency characteristics of two of the transmitters with a representative No. 1 C.B. transmitter for comparison are given in an accompanying figure. It will be seen that the characteristic is a considerable improvement over that of the No. 1 Transmitter.

**Reproducibility.** It was found that if proper precautions were taken in manufacture and assembly, different transmitters gave very similar efficiencies, and a transmitter could be dis-assembled and re-assembled without appreciable change in efficiency.

**Manufacturing Development.** These results were considered so satisfactory that steps were taken, under the usual Departmental procedure, to obtain Provisional Protection. The Department then approached Messrs. Siemens Bros., with a view to their taking up the provision of commercial models, as it had been found that that Company had been developing a micro-telephone and had reached about the same position as the Department. Tests of Messrs. Siemens transmitter, which was of quite different design, gave results almost identical in all respects with those obtained with the Department's transmitters. It was therefore decided to make certain small mechanical modifications with a view to the use of either transmitter in a common handle. Messrs. Siemens Bros. were given an order for a considerable number of each pattern with a view to both types being given a commercial trial.

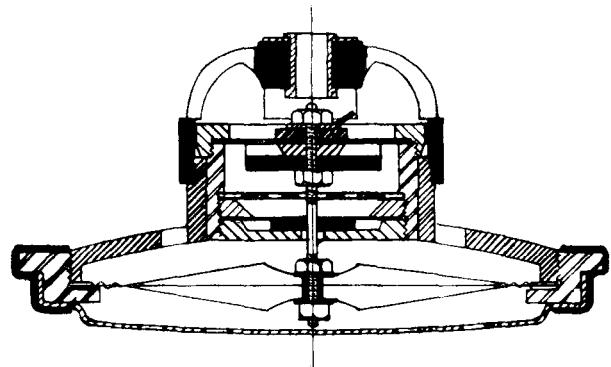

FIG. 5.—P.O. TYPE TRANSMITTER.

Particulars are given in the accompanying drawings and photographs of the complete instrument, and of both the P.O. and Siemens pattern transmitter, either of which can be used in the one handle.

A short description of each transmitter is given.

*P.O. Transmitter.* The diaphragm receiving the sound is a double cone aluminium piston,

carbon electrode. This is polished and is of the same size as the front electrode of the No. 1 Transmitter but it has no brass backing. Clamped to it, as shown, is the mica diaphragm which closes the side of the granule chamber remote from the piston diaphragm. The other electrode is an annular ring of brass, gold-plated, and perforated with a number of holes. These holes allow of free granule movement

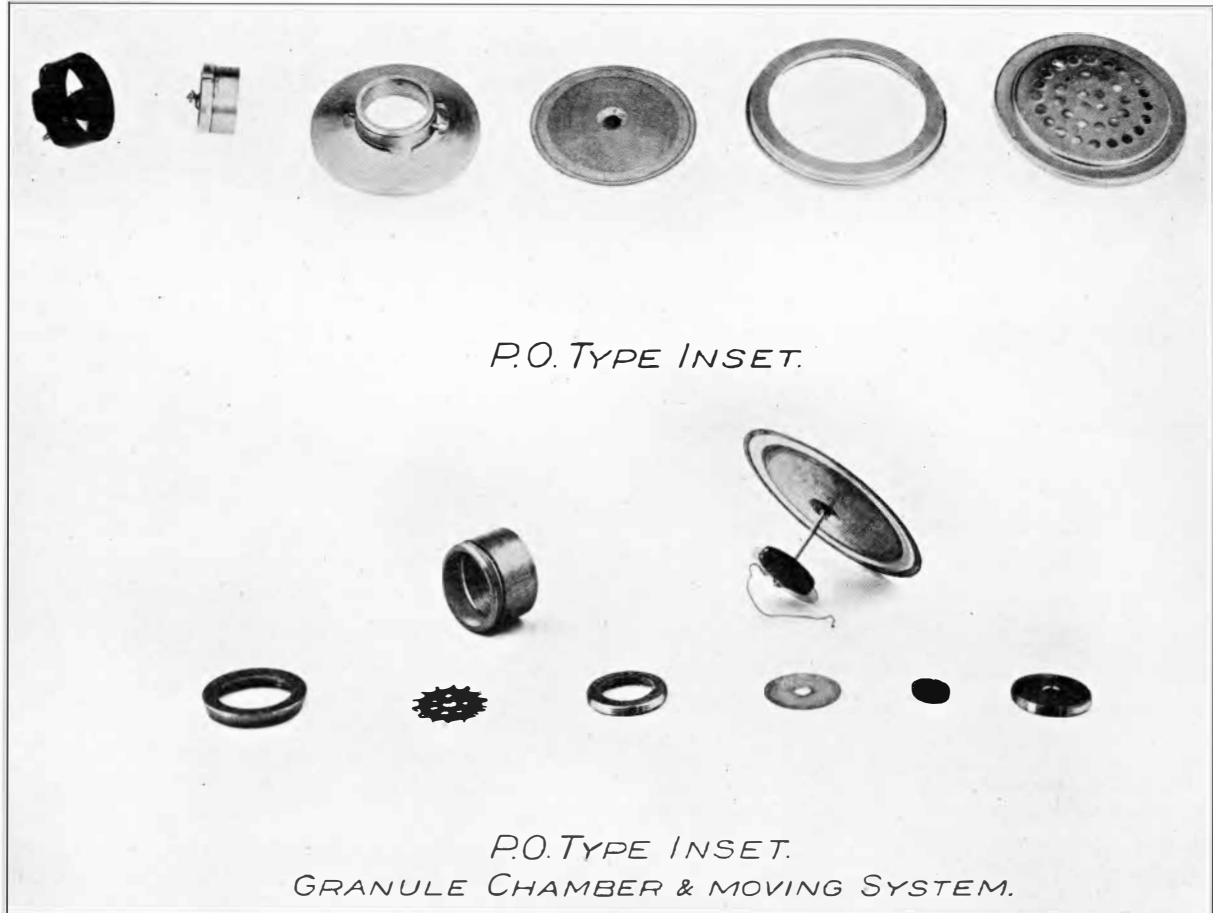

FIG. 6.

the two cones being riveted together with a perforated ebonite rivet, and clamping between them an annulus of aluminium foil. The outer edge of this is strengthened by two thin brass rings cemented to it. These form the clamping surface. Through the ebonite centre rivet a small bolt is passed to which the piston is bolted. The bolt passes (insulated) through the granule chamber and carries the moveable

and cause a lower resistance than occurs with a solid electrode. They also render more easy the filling in of the granules. It will be seen that both electrodes are almost completely embedded in granules and that as the transmitter is turned over on its back more and more of the granules are carried by the moveable electrode. This ensures the maintenance of good working in any position.

*Siemens Transmitters (Patent No. 308630).* The diaphragm receiving the sound is a single corrugated aluminium cone. Attached to the centre is a small aluminium cylinder, the other end of which carries one electrode (carbon). This cylinder projects into the granule chamber as shewn. The other electrode, also of carbon,

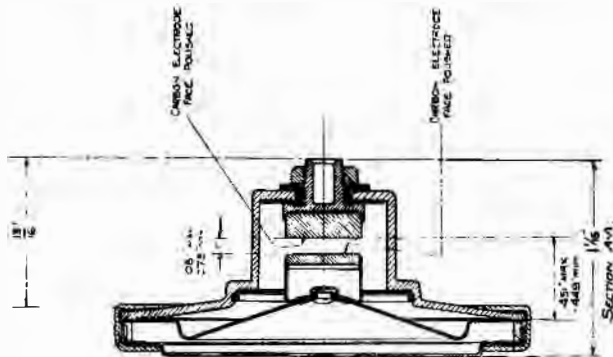

FIG. 7.—SIEMENS TYPE TRANSMITTER.

is mounted at the base of the granule chamber, which is of such a size that the two electrodes are correctly spaced apart at about the centre of the chamber. The granules are prevented from

escaping by annuli of silk clamped in the granule chamber and forming a sliding fit on the cylinder attached to the diaphragm.

*Receivers.* The only special points about the receivers are the provision of a substantial aluminium case, giving a good seating for the diaphragm, and the use of a straight cobalt steel magnet. The receiver is attached to the handle by two clamping screws which also form the terminal connections.

*Side Tone and Extraneous Noise.* The high efficiency of these instruments produces very considerable side tone, and also renders any noise in the room very distressing. It was agreed that some form of anti-side-tone circuit was essential, and the most effective arrangement was considered to be one which had been brought out by Messrs. Siemens. This consists in the addition of a small subsidiary, two-winding induction coil, one winding being connected across the receiver terminals and the other across the transmitter, and so connected that the subsidiary output from the transmitter into the receiver is in opposition to the normal transmitter output into the receiver.

The inherent effect of this coil is to reduce the sending efficiency by about 2 d.b. but this

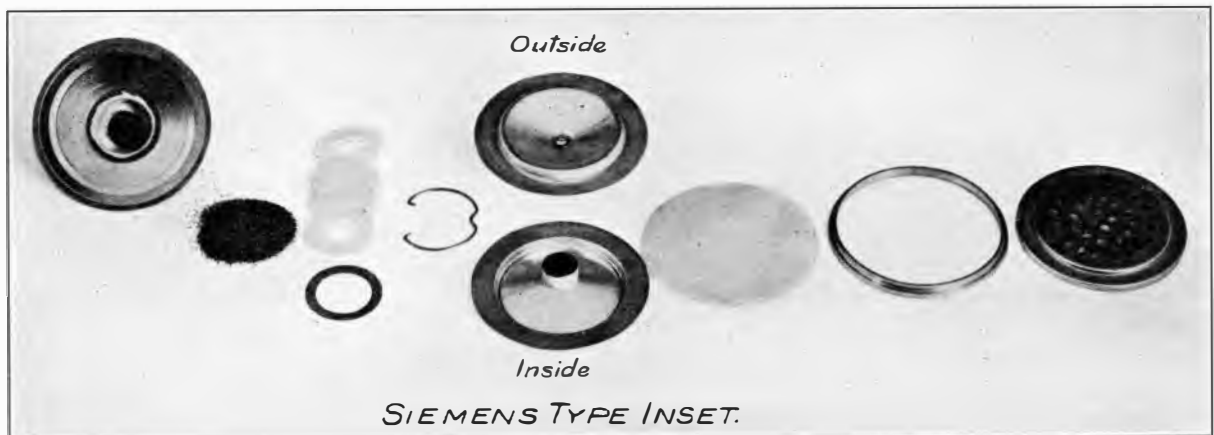

FIG. 8.

escaping by annuli of silk clamped in the granule chamber and forming a sliding fit on the cylinder attached to the diaphragm. It will be seen that in this pattern also both electrodes are almost completely embedded in granules in any position of the transmitter.

Both transmitters are made up as insets, contact being made in the same way in each, viz.: by plug and socket for one connection and

is almost exactly compensated for by the fact that in practice when the side tone is reduced the voice is somewhat raised in volume. Reception efficiency is reduced by about 0.5 d.b. The side tone and extraneous noise are reduced by from 7 to 10 d.b. The subsidiary coil is mounted in the base of the cradle. The instrument is connected to the Bell Set No. 1 by the usual three conductor cord and can be used

interchangeably with Telephones Nos. 2, 124, etc.

*Performance.* A number of difficulties have been experienced in testing these instruments. These are due:—

- (1) To the large differences obtained in efficiency with different speakers due to:
  - (a) Size of head.
  - (b) Shape of head.
  - (c) Character of voice.
- (2) The effect of the side tone.
- (3) The effect of the presence of the instrument on the head in its relation to the picking up of the sound vibrations, other than directly on the diaphragm.

In normal transmission testing the receiver at the sending end is not held to the head, but in this case it must play some part. The use of a guard to fix the distance of the speaker is inadmissible, partly, because it eliminates the effect of any communication of sound down or from the handle and, partly, because a man with a large head will produce much side tone and will therefore tend to reduce his voice more than will a man who produces less side tone.

The method finally adopted to determine the

efficiency is to use 20 speakers, each man holding the microtelephone to the head in the normal way. The anti-side-tone coil is in use, and the microtelephone receiver also alive. On the standard circuit a transmitter and receiver, as nearly as possible each equal to standard, are used, and the receiver held on the ear when speaking. Several microtelephones were thus standardised against the usual standards and used subsequently as substandards to calibrate other microtelephones. For this calibration, substandard and test microtelephones were each fitted with wire guards at approximately the average speaking distance and the guards spoken to close up as to a No. 1 C.B. transmitter.

Four P.O. instruments were selected as substandards, the sending allowance of the complete instrument, obtained as outlined, being in each case 0, in terms of the Department's standard.

A number of instruments of each pattern (constructed by Messrs. Siemens Bros.) have now been tested and the following Table gives the results.

All results are in terms of the Department's Standard transmitter or receiver.

Trans.	No. tested	Allowance in d.b.		Resistance * ohms	
		Mean	Range	Mean	Range
P.O.	25	1.5 Better	0.2 Better— 3.5 Better	47	39—55
Siemens	45	1.5 Better	0.1 Worse— 3.4 Better	45	35—60
Receivers	70	0.9 Worse	1.0 Better— 3.7 Worse		

\* These figures include the anti-side-tone coil.

The articulation of both types of transmitter is distinctly superior to that of the No. 1 C.B. transmitter, but it is difficult to give a quantitative statement of the amount. Results have been obtained with these samples varying from 4% Better to 45% Better. The figure depends upon the observers making the test, upon the conditions of the test and upon the circuit conditions. For example, a direct test between a No. 1 C.B. transmitter and the microtelephone on the working circuit does not necessarily produce the same relative articulation efficiency as is obtained by a test of each instrument against a distortionless circuit. The two patterns of

transmitter are found to give practically identical results, and probably an average figure of about 15% better than standard is about right.

All the transmitters are satisfactory as regards frying when the microtelephone is held on the head, the latter being vertical. About 20% exceed the allowable amount when the head is held at 45°, and most are unsatisfactory when the head is held with the line through the ears vertical. This position is only reached with very considerable discomfort.

Tests have also been made of the possibility of sparking occurring in the transmitter whilst being lifted from or replaced on the switch-hook.



---

With the Siemens type of transmitter it was found impossible to produce a disconnection in the transmitter whilst the switch-hook contacts were closed.

With the P.O. type a disconnection could only be produced when the microtelephone was replaced on the cradle in a very violent manner. With neither type did the resistance rise to any

very high values when the microtelephone was handled normally.

It should be mentioned that since the preliminary samples have been obtained, various minor modifications have been made in the P.O. inset. These should result in an even better transmitter.

---