

# THE POST OFFICE ELECTRICAL ENGINEERS' JOURNAL

---



## SUBSCRIBER TRUNK DIALLING

Vol. 51 Part 4

JANUARY 1959

# The Pay-on-Answer Coin-Box System

F. J. BASTOW, B.Sc.(Eng.), A.M.I.E.E., J. D. COLLINGWOOD, A.M.I.E.E.,  
E. NEWELL, B.Sc.(Eng.), A.M.I.E.E., and C. K. PRICE†

U.D.C. 621.395.663.6:621.395.374

A new method of coin-box working was needed in conjunction with subscriber trunk dialling. A pay-on-answer system was evolved requiring the development of a completely new coin-box and the design of associated exchange equipment; these are described in this article.

## INTRODUCTION

THE present coin-collecting box with its A and B buttons is nearly 35 years old in its basic design, and although it has from time to time been compared unfavourably with foreign systems having automatic collection and refund facilities, it has given good service. The system needs no special equipment at the exchange and is therefore simple and inexpensive. The Post Office is, however, introducing subscriber trunk dialling (S.T.D.) to reduce the number of operators required for completing trunk connexions, and as approximately one-third of the trunk calls made during the cheap night-rate period originate in call offices, it would be undesirable to exclude these from the scheme. No reasonable modification would have enabled the present box to be used to pay for automatically connected trunk calls and hence a new design of box was required.

Other requirements for which a new coin-box must cater include: the public demand for a slot to take a 3d. piece; the desire to time local calls from coin-boxes; the need for a simple method of adjusting the call charges, and the desire for a box of more pleasing appearance. These factors led to the development of a new coin-collecting system.

## THE CHOICE OF A SYSTEM

The requirements could be met by either pre-payment or post-payment systems but attention was focused on the post-payment system because it avoided the need to hold money in suspense and thus permitted the A and B buttons to be eliminated without introducing the need for automatic deposit and refund mechanisms. A further advantage of a post-payment system is that it is intrinsically free from many types of fraudulent operation. Basically, the new system requires that money should be inserted to connect the speech path after the call has been set up and the called subscriber has answered. Once coins have been inserted they cannot be recovered by the caller, although worn or spurious coins will be rejected by the equipment. The new system has been named "pay-on-answer" to distinguish it from the existing manually controlled post-payment system.

A 3d. slot was an accepted requirement and it was considered that this slot should replace the 1d. slot of the present coin-box. This considerably increases the amount of money which the self-sealing cash container can hold and thus permits less-frequent clearance of the box. With 3d. as the basic unit the signalling code can

take the form of one pulse for 3d., two for 6d. and four for 1s.

The remaining point to be considered was the method of charging. The new coin-box has to provide coin-box users with the full range of S.T.D. facilities. It has therefore to operate in conjunction with a periodic-metering system<sup>1</sup> on both local and S.T.D. calls. This implies that the pay-on-answer system should allow for extensions of a call by the insertion of further coins at various times throughout the call; the values of these coins being signalled to the exchange equipment, where they are recorded and compared, for each call, with the number of levied meter-pulses received.

Summarizing, the essential features of the system are as follows:

(a) Payment for calls should be made when the called subscriber answers and not, as with the present box, before dialling.

(b) There should be no buttons.

(c) The box should be capable of providing trunk-dialling facilities.

(d) There should be facilities for timing local calls and for extending the duration of these and other dialled calls by the insertion of additional money.

(e) The penny slot should be replaced by one for threepenny pieces.

## OPERATION OF THE SYSTEM

### *Automatic Call*

Referring to Fig. 1, on an automatic call the caller lifts the receiver, listens for dial tone and then dials the number.

(1) If the called subscriber is engaged, busy tone is returned and the caller clears.

(2) If the number is unobtainable, N.U. tone is returned and again the caller clears.

In cases (1) and (2) the coin slots remain locked and therefore coins cannot be inserted.

(3) If the called line is free, ring tone is returned to the caller.

When the called subscriber answers, the coin slots are unlocked and pay tone replaces ring tone. This pay tone, which is heard by both calling and called subscribers, informs the caller that coins must be inserted, and the called subscriber that the call is from a coin-box user.

(4) If the caller fails to insert coins then the pay tone persists for some 10 seconds, at the end of which time the coin slots are locked; 2 seconds later the call is "force-released" and N.U. tone is returned to the caller.

(5) If the caller inserts a coin (or coins) the pay tone is disconnected, the transmission path is opened and the conversation can begin.

When the period has elapsed for which payment has been made, pay tone is reconnected for some 3 seconds to inform both subscribers that the caller must insert a further coin (or coins) if the call is to continue.

(6) The caller may decline to insert a coin, and clear, or

(7) he may insert further coins. In this case pay tone

† The authors are, respectively, Senior Executive Engineer, Engineering Organization and Efficiency Branch (formerly of the Telephone Exchange Systems Development Branch), Executive Engineer, Subscribers Apparatus and Miscellaneous Services Branch, and Executive Engineer and Assistant Engineer, Telephone Exchange Systems Development Branch, E.-in-C.'s Office.

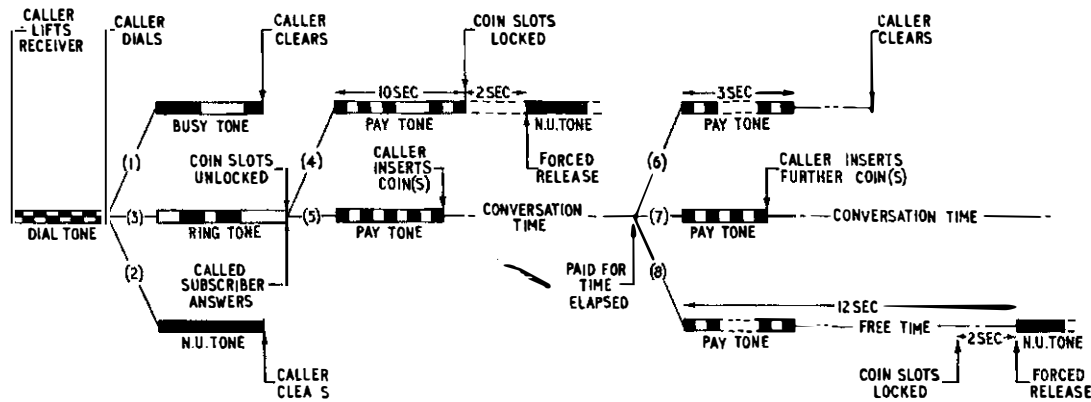

FIG. 1—AUTOMATIC CALL

is disconnected and the conversation may continue.

(8) The caller may, however, decline to insert further coins but continue the conversation, in which case the coin slots remain unlocked for some 10 seconds; after a further 2 seconds the call is force-released.

The transmission path is not disconnected during periods of subsequent pay tone and the 12-second period from the commencement of that tone until forced release is free time; only one free period is given per call although the application of pay tone may occur as often as is necessary. The coin slots are normally unlocked throughout the call from the time the called subscriber answers until clear down or forced release, and thus the caller may insert coins at any time. Pay tone consists of a 400 c/s tone interrupted at approximately 0.2 seconds on, 0.2 seconds off, although this may be changed as a result of international agreements.

#### Manual-Board Call

The origin of a call will be indicated at the exchange by either a distinctive lamp or, where the ordinary and coin-box junctions are in a common group, by the application of pay tone to the line when the operator answers. This discriminating tone, which cannot be heard by the caller, is disconnected by a momentary operation of the manual-board-position ring key.

When the operator requires the caller to insert coins into the box the coin slots are unlocked by a second momentary operation of the ring key. Each basic unit of money causes a 400 c/s pip of tone to be signalled to the operator, i.e. one pip for 3d. two for 6d. and four for 1s. This method of signalling eliminates the somewhat unsatisfactory existing method using gong and bell signals. The latter signals have been found difficult to distinguish on rural lines and where extraneous noise is present, and they also lend themselves to fraudulent simulation. Should the operator wish to recheck the amount of money inserted in the box during the call a further momentary operation of the ring key will cause the pips of tone to be repeated, equal in number to the actual amount inserted or to the amount in excess of any multiple of 24 units. For ease of counting, the pips are grouped into fours and, when rechecking, the slots are locked to prevent interference from other coins being inserted. This facility, which is referred to as an "audit" facility, may be used as often as is desired.

#### TECHNICAL OUTLINE OF THE SYSTEM

##### Trunking

Fig. 2 shows the basic trunking arrangement for a

coin-box line in a non-director exchange. Each 1st selector in the coin-box group is preceded by a coin and fee checking (C.F.C.) equipment, as shown in the diagram.

#### Coin-Box Line Signalling

Two signals are required: the first is a signal, sent from the exchange to the coin-box, to unlock the coin-slots; the second is a signal from the coin-box to the exchange to indicate the value of coins inserted. If consideration is limited to a method of slot unlocking using direct-current signals, then the most satisfactory signal for coin-slot control is a reversal of the line potentials.

The coin-signalling system has to meet a wider range of requirements, and that chosen as offering the best compromise between simplicity in the coin-box and economic provision of equipment at the exchange is a loop/resistance method. As its title indicates, the signal consists of the reduction in line current caused by the insertion, at the coin-box, of a resistance of 5,000 ohms in the line loop. Each reduction in line current represents a single coin pulse and, to facilitate identification of a group of one, two or four coin pulses, the coin-pulse train is terminated by a short disconnection of the line. Fraudulent simulation of the signal, e.g. by interfering with the handset cord, has been made difficult by suitable arrangement of the coin-box circuit; access to the lead-in wires has also been made difficult. A pulsing speed of 4 p.p.s. and a loop/resistance time ratio of about 2 : 1 have been chosen to ensure correct functioning of the

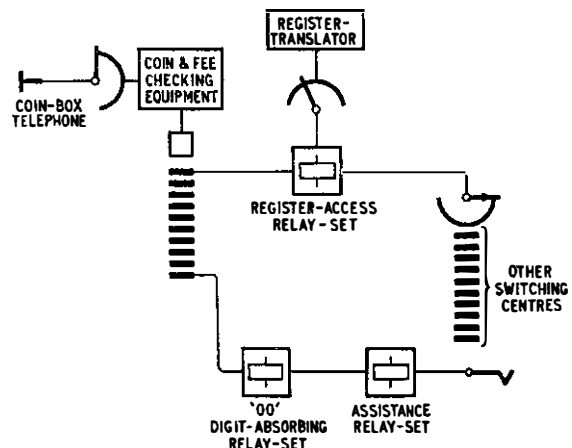

FIG. 2—TRUNKING OF COIN-BOX CIRCUITS AT A NON-DIRECTOR EXCHANGE

exchange meter and to facilitate the counting of tone pulses by the operator. It is hoped that the simplicity of the system will aid its reliability.

### Manual-Board Signalling

A signal is required between the manual-board termination and the C.F.C. equipment for the purposes of coin-slot control, audit and, if required, coin-box discriminating-tone signalling. In director and discriminating satellite exchanges arrangements are made for this signal to bypass the 1st code selector, discriminating selector repeater (D.S.R.) or satellite 1st selector. Bypassing is achieved by providing an extra pair of wires from the outgoing side of the selector or repeater to the C.F.C. equipment. A further requirement is that the signal from the manual board must be inactive within the 1st code selector, D.S.R. or satellite 1st selector; this precludes the use of a reversal. In addition the signal-detecting element within the C.F.C. equipment must be of high input-impedance since it is required to be permanently connected across the outgoing positive and negative wires of the selector in the presence of speech. The signal used is a positive-battery pulse and the detecting circuit employs a transistor.

### Treatment of Automatic Calls

When the call is answered by the called subscriber, receipt of the first meter pulse causes the C.F.C. equipment to cut the transmission path and return pay tone to both the called and calling lines. On local calls subsequent meter pulses are generated within the C.F.C. equipment whilst on calls completed by a register-translator they are returned from the associated relay-set. These latter meter pulses from the succeeding equipment arrive at the C.F.C. equipment after the appropriate period, irrespective of whether a coin has been inserted or not, and to give correct charging it is necessary to delay their effect by a time equal, in the first instance, to the interval between the receipt of the first meter pulse and the reconnection of the transmission path on the insertion of the first coin. On national or international calls, where the metering rate is high, one or more of these pulses could arrive in the C.F.C. equipment during the initial pay-tone period and before the insertion of a coin, and arrangements must be made in the equipment to avoid any difficulties arising from this cause. The problem and the preferred solution to it are illustrated in the sequence chart of Fig. 3. It will be seen that a meter pulse (No. 2) is absorbed if it occurs before insertion of the first coin (A), and the time interval ( $t_1$ ) between meter

pulse 2 and the insertion of coin A is restored to the caller by delaying the levying of the next meter pulse (3). The extra 1 second of delay is explained later.

The arrangement to be used in the initial installation at Bristol follows a different principle. Pulses from the tariff-control equipment at six times the metering rate are repeated by the register-access relay-set and returned to the C.F.C. equipment, and a "divide by six" circuit is switched into use in the C.F.C. equipment only on insertion of the first coin. This circuit applies the first periodic pulse after counting seven supply pulses, to ensure that the first time interval is not less than the metering period, and thereafter a meter pulse is applied for every six supply pulses received. This was satisfactory at the time it was approved for use at Bristol, except perhaps for the rather frequent presence of positive-battery metering signals (a pulse every 2 seconds on a call of over 50 miles radial distance); subsequently, however, it was decided that it did not give adequate flexibility for possible future changes in tariff and that it would not be satisfactory for international subscriber-dialled calls. In addition, the maximum metering rate of one per second which can be handled by the metering-over-junctions system<sup>2</sup> would limit the international charging rates even if the divide factor were reduced to below six.

Referring again to Fig. 3, another difficulty brought into prominence on a high-metering-rate call is the loss of conversation time whenever a coin is inserted. On such calls this loss will be restored to the caller by delaying the levying of each subsequent meter pulse by 1 second for each coin after the first, as shown by coin B and meter pulses 3 and 4 and by coins C and D and meter pulse 5. When the delay time becomes greater than the metering period (6 seconds in the example) a meter pulse is absorbed and the delay reduced accordingly. This is illustrated by meter pulses 5, 6 and 7; pulse 5 is delayed by a total time of  $t_1 + 3 = 7$  seconds and consequently pulse 6 is absorbed and the delay is reduced to  $t_2$  (i.e.  $7 - 6 = 1$  second). As no more money is inserted, pulse 7 and subsequent meter pulses are delayed by this time only.

Meter pulses 8 and 9 illustrate a further facility which is required on high-metering-rate calls, such as will occur with international subscriber dialling, when a meter pulse (9) arrives during the subsequent pay-tone or the free time period and causes a debt of 6d. This meter pulse is arranged to lock the slots and, 2 seconds later, to force release the call unless, prior to the slots locking, a coin has been inserted capable of taking the caller out of debt; a minimum of 6d. is required.

On lines from public call offices the C.F.C. equipment

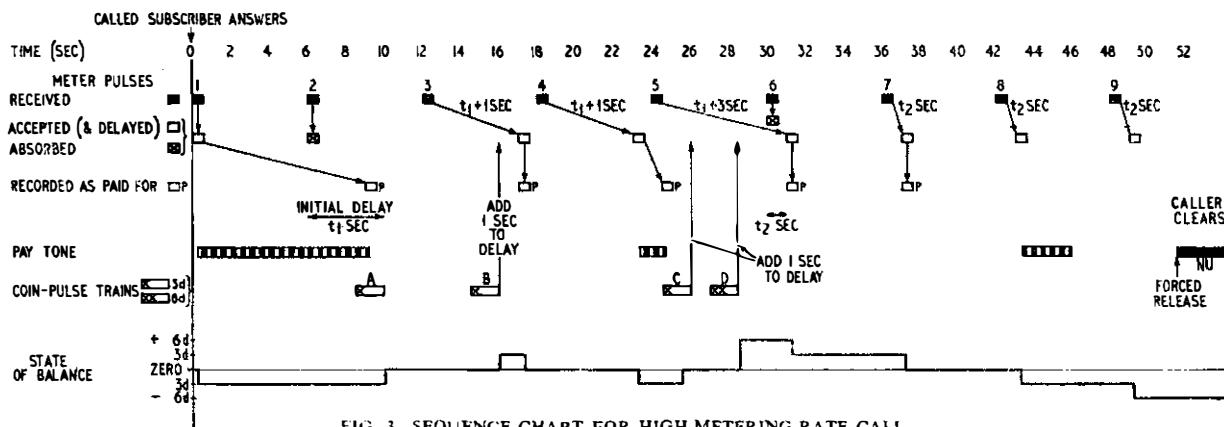
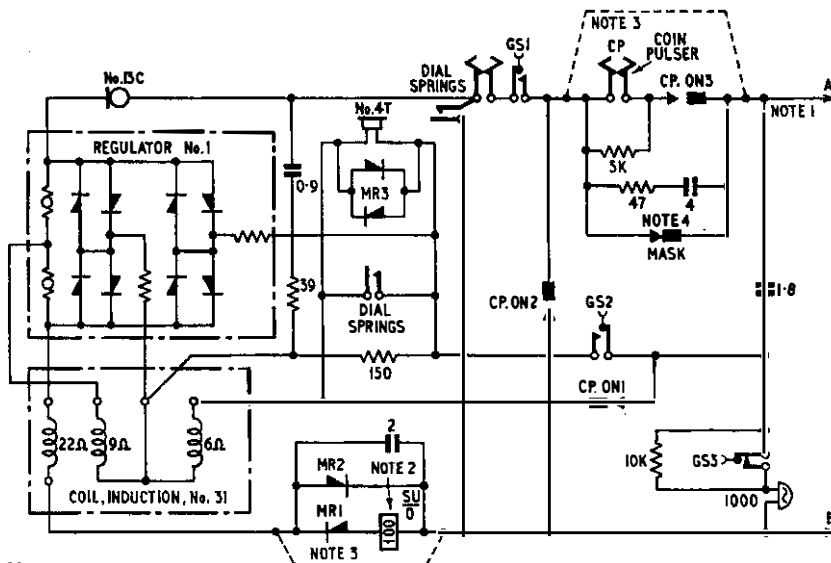

FIG. 3.—SEQUENCE CHART FOR HIGH-METERING-RATE CALL



- Notes:
1. The A line is positive until the called subscriber answers, then negative.
  2. Relay SU unlocks coin-slots when energized by current reversal (See Note 1).
  3. These points are connected by a jack to provide "999" service with the mechanism removed.
  4. The "Mask" springs are shown operated.

FIG. 4.—PAY-ON-ANSWER COIN-BOX CIRCUIT

provides for recording all coin pulses on the exchange meter. On a subscriber's coin-box line, only those meter pulses are recorded (labelled P in Fig. 3) for which a corresponding coin pulse has been received. This ensures that the subscriber is not charged for answered calls for which a coin is not inserted.

#### Coin and Meter Pulse Registration

Provision is made in the C.F.C. equipment for incoming P, PM and M wires. The P wire provides holding and guarding facilities with or without positive-battery coin pulses. The PM wire provides holding and guarding facilities with positive-battery meter pulses or merely returns negative-battery or earth meter-pulses. In both cases meter-pulse registration is dependent upon one coin pulse per meter pulse having been received, i.e. the meter pulses registered must have been paid for. The M wire returns negative-battery or earth coin-pulses.

These alternatives cover all existing exchange metering systems and permit the use of two meters per coin-box line for the recording of both coin and paid-for meter pulses. With a single meter per calling equipment the public coin-box meter would be connected to record coin pulses and the subscriber's coin-box meter to record paid-for meter pulses.

#### CIRCUIT DESCRIPTION

##### Coin-Box Circuit

Fig. 4 shows the circuit of the coin-box. The telephone circuit itself is basically that of the new 700-type telephone.<sup>3</sup> Auxiliary dial springs are not required and hence the dial is of a standard type. A 100-ohm relay, SU, made sensitive by rectifiers to line reversals, is inserted to control the unlocking of the coin slots, but there is no reduction in the

1,000-ohm line limit of the 700-type telephone, because the low-resistance line-signalling relay in the C.F.C. equipment transmission bridge sufficiently compensates for the resistance of relay SU.

The resistance coin-pulses are generated by the coin pulser CP contacts, the resistance-capacitance network acting as a spark quench in addition to minimizing the click heard by the called subscriber at the commencement of each coin train. The functions of the off-normal springs (CP.ON) are given below, and Fig. 5 shows their timing relative to the coin pulses. The first coin pulse is 10 ms longer than subsequent ones to allow for its initial recognition in the C.F.C. equipment whenever coins are inserted.

(a) CP.ON1 short-circuits the receiver during coin pulsing. As the introduction of relay SU increased the direct current

flowing through the receiver, the current was reduced to its normal value by the 10,000-ohm resistor switched in by GS3 to minimize the click when CP.ON1 operates.

(b) CP.ON2 is required to ensure that the line is closed by a precise 5,000-ohm coin-pulsing condition and to prevent interference with the coin pulsing by the gravity switch, the dial, or by the variable resistance of the transmitter. It was found, however, that its operation before commencement of coin pulsing, i.e. while the line current was high, caused a click to be heard by the called subscriber. Hence it is timed to operate approximately 50 ms after the commencement of the first coin-pulse, by which time the exchange equipment has disconnected the transmission path and thus prevented the called subscriber hearing any resulting click. The caller is, of course, protected by the CP.ON1 receiver short-circuit.

(c) CP.ON3 initiates the full break at the end of a coin train.

(d) Mask Contact. This prevents signals being sent by a rejected coin or by a coin which is finally withdrawn. Its resetting at the end of the cycle terminates the full break.

##### Coin and Fee Checking Circuit

The primary functions of the coin and fee checking

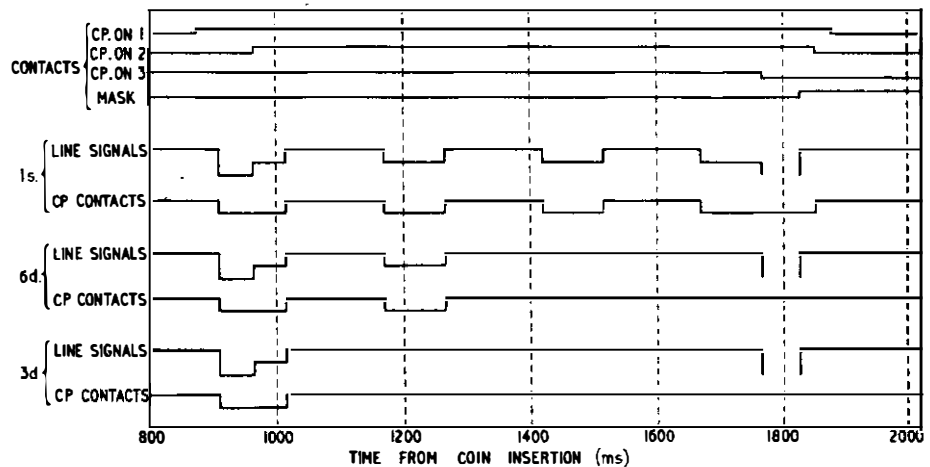
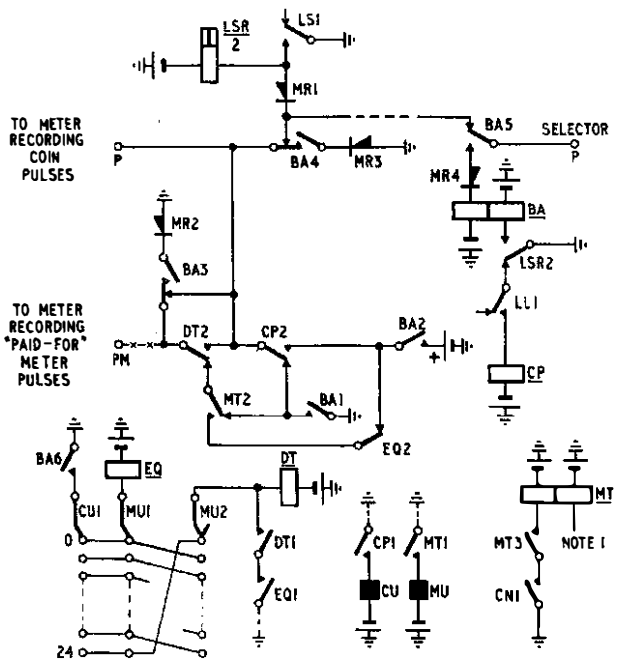

FIG. 5.—PULSER TIMING CHART





- Notes:
1. Accepted meter pulses from Fig. 10 (S.T.D. call) or from local-call timing element.
  2. The contacts marked CU1, and those marked MU1 and MU2, are the wiper and bank contacts of uniselectors CU and MU respectively.
  3. The strapping (x-x) shown is that appropriate to a positive-battery-metering exchange.

FIG. 8—COIN AND METER PULSE COMPARISON AND REGISTRATION CIRCUIT

voltage does not exceed the maximum specified for the transistor. Fig. 7 shows also the method of controlling the coin slots. On seizure, the line polarity is such that relay SU in the coin-box remains normal and operates to unlock the slots only on the operation of relay LR.

**Comparison and Registration of Coin and Meter Pulses.** Fig. 8 shows the circuit element used to determine the state of the balance between the total number of coin pulses received and the total number of levied meter-pulses. The figure shows also the circuit element used to control the coin-box line-circuit meter, which may be associated with terminal P or PM, as required, to record "Total Coin Pulses" or "Total Paid-for Meter Pulses." Additional circuit arrangements allow for negative-battery or earth paid-for meter-pulses on terminal PM and include a terminal M (not shown in Fig. 8) to cater for negative-battery or earth coin-pulses.

On seizure, contact LSI earths terminals P and PM to give fast guarding and holding conditions and operates relief relay LSR. Contact LSR2 operates relay BA, and contact BA1 takes over the guard and hold functions. Contacts BA3 and 4 provide alternative earth conditions via rectifiers MR2 and 3 to cover the transit time of the actual metering contacts. Contact BA5 splits the P wire to permit interception of the metering pulses returned from the succeeding equipment.

Uniselectors CU and MU are actuated, respectively, by coin pulses via relay CP and "accepted" meter pulses via relay MT, and take up positions throughout the call corresponding to the totals of those pulses received. The state of the caller's balance during the call is indicated by relays EQ and DT, which are controlled by arcs CU1, MU1 and MU2. There is a credit whilst both relays are normal, a zero balance when relay EQ only is operated, and a debit when relay DT only is

operated. The holding circuit for relay DT (contacts DT1 and EQ1) ensures that relay DT remains operated should a further meter pulse be received while in debt. This situation can arise with international-call metering rates and results in the locking of the coin slots, followed some 2 seconds later by forced release. If, however, a coin is already in transit it must be detected and the call permitted to proceed only if, at the termination of the coin train, relay DT is normal.

Contact CP2 extends positive battery to terminal P for each coin pulse and, when there is a debit at the time of payment, to terminal PM. While there is a credit balance terminal PM is pulsed by successive accepted meter-pulses via contact MT2. When the balance becomes zero, contact EQ2 operates and inhibits contact MT2 to prevent the next accepted meter-pulse, which has not been paid for, from producing a corresponding pulse at terminal PM. However, contact MT1 steps uniselector MU, and relay DT operates to initiate a pay demand. Terminal PM will be pulsed again by contact CP2 only during the coin train which must follow if the call is not going to be terminated. In order that contact DT2 shall not clip a pulse from contact CP2 it is necessary to ensure that, whenever a coin-pulse train and an accepted meter-pulse overlap, the meter pulse is extended until the end of the train. This is achieved by holding relay MT via contact MT3 and coin-pulse-train relay contact CN1 until relay CN releases at the end of the coin-pulse train.

**The Delaying of Meter Pulses.** The two remaining uniselectors TU and DU are associated with local-call timing, the accumulation of delay time and the delaying of meter pulses on S.T.D. calls. Uniselector DU, stepping at a rate of one outlet per second, times and stores the interval between the meter pulse, received from the succeeding equipment on called-subscriber answer, and the insertion of the first coin. However, should any subsequent meter pulses be received from the succeeding equipment during this period, the uniselector must home and recommence timing. It must also step once for each subsequent coin inserted to compensate for the resulting loss of conversation time. These requirements are met by the circuit shown in Fig. 9. At the end of the initial meter pulse a relay MY operates and contact MY1 extends the drive circuit for uniselector DU to contact

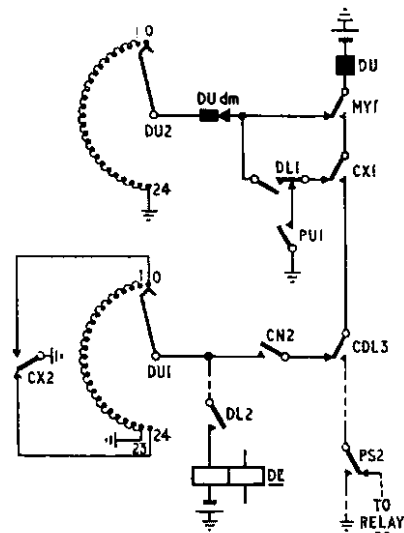

FIG. 9—DELAY TIME CIRCUIT



PU1, which is pulsing at 1 p.p.s. The insertion of the first coin operates a relay CX which, at contact CX1, disconnects this drive circuit, the operation of relay CX being inhibited during a PU make-pulse to prevent clipping of that pulse. Relay DL operates for each subsequent meter pulse and, prior to the insertion of coins, i.e. with contact CX1 normal, contact DL1 causes uniselector DU to home. During homing a DL contact inhibits the operation of relay CX to prevent interruption of the homing circuit should a coin pulse be received. Coin-pulse-train relay contact CN2 steps uniselector DU once for each coin received. With contact CX2 operated, arc DU1 allows for a delay time of up to 23 seconds. On an S.T.D. call, each meter pulse from the succeeding equipment received after the insertion of coins is delayed by the delay time currently recorded on uniselector DU, before operating relay MT.

If a further meter pulse is received during the delay of the previous pulse, i.e. when the delay time exceeds the metering period, this further pulse must be absorbed and time equal to the metering period deducted from the delay time. Fig. 10 shows the circuit operation. A trunk-call relay TC operates on receipt of the second meter pulse and contact TC2 homes uniselector TU which, until this stage of the call, has been performing as a local-call timer. Relay DL operates to the second

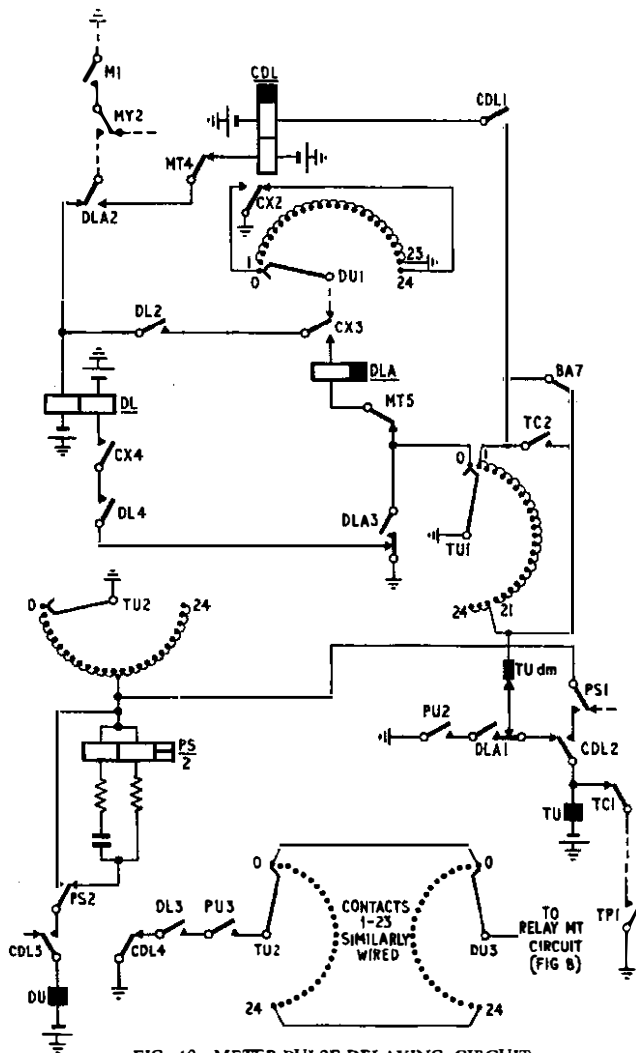
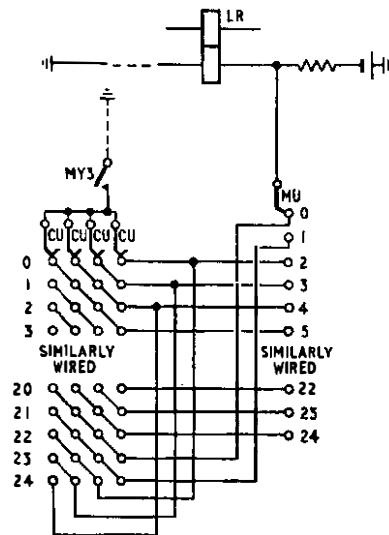

FIG. 10—METER-PULSE-DELAYING CIRCUIT

and subsequent meter pulses and, at contact DL2, prepares a circuit for relay DLA. With uniselector TU in its home position, and following the insertion of coins (CX3 contact operated), relay DLA operates and contact DLA1 connects one-second PU pulses to the TU magnet. The 1 p.p.s. stepping of uniselector TU continues until a PU pulse via arcs TU2 and DU3 operates relay MT. Contact MT5 releases relays DL and DLA so that uniselector TU homes. When a further meter pulse is received during the delaying period relay CDL operates and contact CDL3 energizes the timing relay PS. In addition, contacts CDL2 and CDL3 place the stepping of uniselectors TU and DU under the control of contacts PS 1 and PS2. Pulsing at a nominal 10 p.p.s., contacts PS1 and PS2 step the two uniselectors until uniselector TU, on stepping to its home position, disconnects the operate circuit of relay PS and releases relay CDL. Stepping of uniselector TU at 1 p.p.s. recommences until relay MT operates to record the previous meter pulse, when relays DL and DLA release, and uniselector TU homes, as before.

**Maximum Credit.** Reference has been made already to arcs CU1, MU1 and MU2 of the coin-pulse and meter-pulse uniselectors (see Fig. 8); further arcs CU2-5 and MU3 ensure that the limited storage capacity of the coin-pulse uniselector is not exceeded, by arranging for the locking of the coin-slots by the release of relay LR when a credit of 20 coin pulses has accrued (see Fig. 11). This allows for the circumstance in which a credit of 19 exists and a shilling is inserted giving a total credit of 23—the maximum that the circuit can accommodate. The slots are unlocked again when the receipt of a meter pulse (or pulses) reduces the credit to 19.



The contacts marked CU and MU are the wiper and bank contacts of uniselectors CU and MU

FIG. 11—MAXIMUM CREDIT CIRCUIT

**Positive-Battery-Pulse Detection.** Fig. 12 shows the circuit used for the detection of positive-battery signals returned, from the manual-board relay-set, to a director or discriminating-satellite exchange. The transistor has a high input-impedance which allows it to remain connected to the line during speech. Its high sensitivity makes it tolerant of positive-battery voltage variations and junction resistance.

**Audit.** A sequence uniselector SU, stepping at a rate



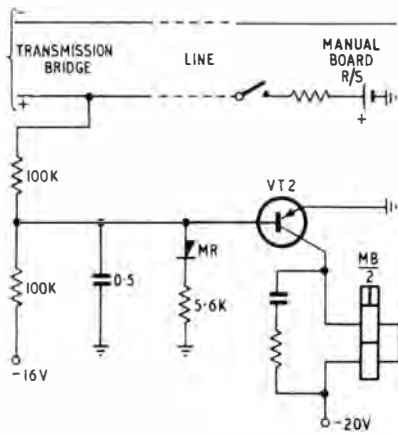

FIG. 12—POSITIVE-BATTERY-PULSE DETECTING CIRCUIT

of one outlet per second, times and controls the initial and subsequent pay-tone sequences. In addition, it is also involved in the generation of pips of tone for the audit facility. Following receipt of a positive-battery signal from the operator demanding audit, a relay AUD operates and contact AUD1 (see Fig. 13) energizes a

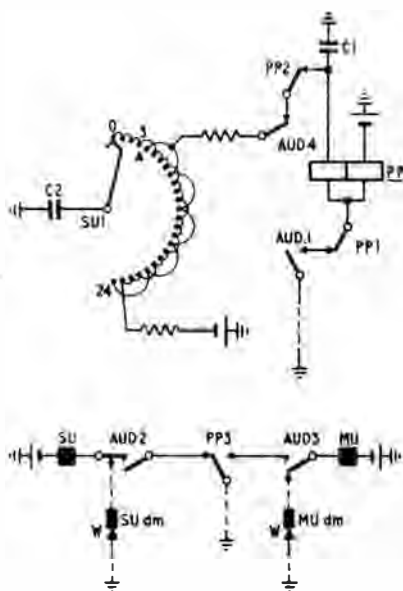

FIG. 13—AUDIT CIRCUIT

self-interacting-relay timing element PP. Relay PP pulses at approximately 0.2 seconds "on," 0.2 seconds "off" and a group of four pulses of tone is sent to the operator as uniselectors SU and MU step over outlets 0-3 under the control of contact PP3. The interval between this group of pulses and the next is achieved by the introduction of an additional capacitor, C2, at outlet 4 to increase the operate time of relay PP. The sending of audit pips and the stepping of uniselectors SU and MU continues in a similar manner until the operation of relay EQ (see Fig. 8) indicates that the number of pulses sent to the operator equals that of the coin pulses as stored on uniselector CU. Relay AUD then releases and uniselectors SU and MU home.

## THE COIN-BOX

The general size and shape of the new box have been determined by the decisions to combine coin-box and telephone in a single instrument; to use aluminium alloy for the casing; and to restrict certain dimensions in the interests of interchangeability with the present box. The final appearance of the instrument is, however, the work of an industrial designer, and has received the approval of the Council of Industrial Design. It is to be known as a "Telephone No. 705" and is shown in Fig. 14.

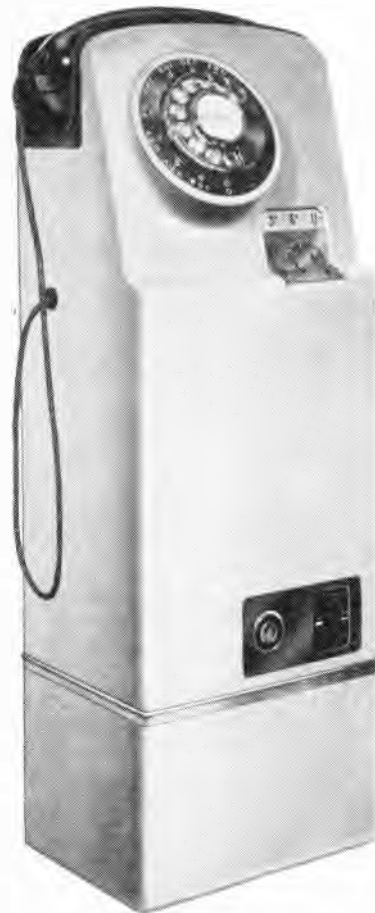

FIG. 14—TELEPHONE NO. 705

### Description

The main sections of the casing are pressure castings in aluminium alloy, thus eliminating the possibility of rusting. The stove-enamelled finish, which will withstand a long period of normal wear-and-tear, is in a warm shade of grey. The handset and handset recess are black while the receiver rests and other bright fittings are of stainless steel. The coin-denomination plate has a matt chromium finish to enhance the legibility of the figures. The handset cord is grebe grey and the dial number-ring and the rejected-coin recess are in forest green, to blend with the case colouring.

The main components of the Telephone No. 705 are shown in Fig. 15. The cash compartment is bolted to the bottom of the backplate and, when assembled, the coin-operated mechanism is jacked into the top portion. The cash compartment and its sliding door are steel lined to give good security and, to prevent the accidental

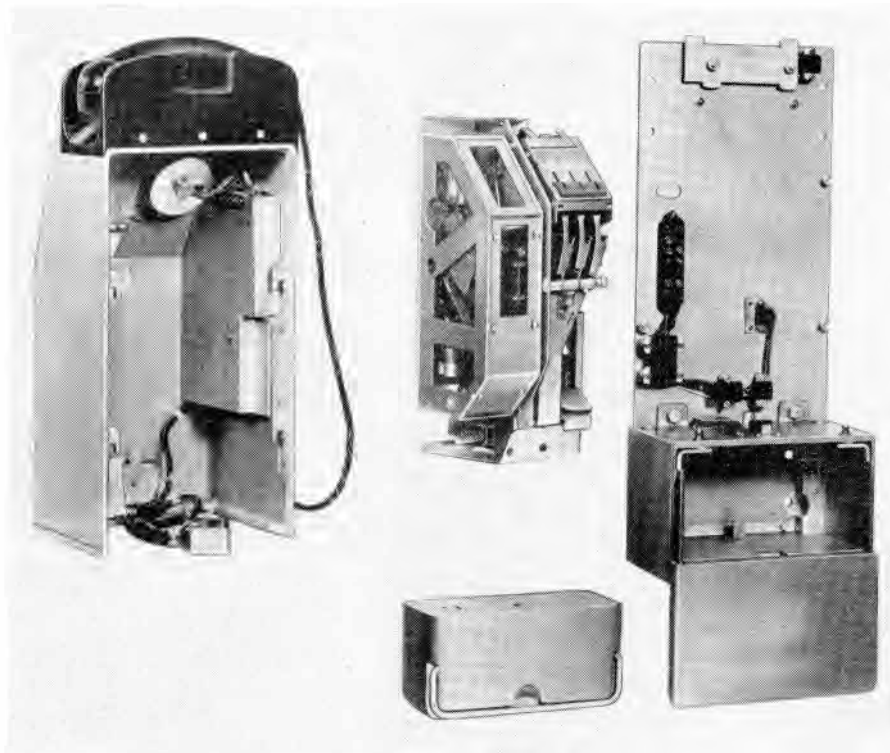

FIG. 15—MAIN COMPONENTS OF THE TELEPHONE NO. 705

omission of the "self-sealer", the door of the cash compartment cannot be fully shut unless a cash container is in position. When unlocked, the door drops downwards and allows the self-sealing cash container to be withdrawn like a drawer. The cover over the mechanism compartment is attached to the backplate in such a way as to make forcible removal difficult, and to prevent any strain being applied to the lock. This cover carries the whole of the telephone equipment so that when the mechanism is removed for maintenance the insertion of a plug into a socket on the backplate enables the telephone circuit to be used for non-chargeable calls. If the telephone is left in this condition for public use, the coin plate aperture is closed by a label stating, "TEMPORARILY OUT OF USE, except for calls to FIRE, POLICE, OR AMBULANCE".

The handset is the same as that used for the new Telephone No. 706, and the receiver rest has been designed to ensure that however the handset is replaced the gravity switch will operate and will not be fouled by the handset cord. Normally the bell-set, which carries the gravity-switch spring-set, is attached to the inside of the cover as shown in Fig. 15, but it can be removed for maintenance without disconnecting the circuit. The reject-coin return has to handle only one coin at a time, and this has enabled it to be designed to present a rejected coin to the caller so that it can be picked up cleanly. The locks of the cash and mechanism compartments and the self-sealer lock are the same as those used on the existing coin-box. Means of releasing the cash compartment or the mechanism cover in the event of a lock failing have been provided.

The coin-operated mechanism is shown in the centre of Fig. 15. The pulser mechanism can be seen on the left and the coin acceptor on the right of the central main frame. The main structural members throughout the

mechanism are of mild steel, cadmium plated and passivated, whilst use is also made of stainless steel, anodized aluminium, nickel-silver and rigid p.v.c. for certain key parts. A transparent plastic cover is fitted over the pulser mechanism; although not airtight, this cover will reduce the amount of dust that settles on the spring sets and will afford protection against normal handling.

#### Operation

The movement imparted to the mechanism as the full diameter of the coin is inserted in the appropriate coin slot raises the pulser cams. When the cams are fully raised the coin falls inwards and the cams then commence to fall at their governed speed. The first half of their fall allows time for the coin to be tested and, during the second half, coin pulses are generated and these are transmitted to line provided that the coin has been accepted.

The coin acceptor has a coin plate with three slots, one each for threepenny pieces (twelve sided), sixpences and shillings. When a coin is pressed into the appropriate slot, the coin attempts to move an arm which has one end projecting part of the way across the slot. There are three such arms, one for each slot, and they have several functions. It is these arms which are electromechanically locked by relay SU under the control of the C.F.C. equipment to prevent the insertion of coins, and mechanically locked while one coin is being signalled to prevent a second coin being inserted before the operational cycle is complete. Before the operation of relay SU, the slots are kept locked by a latch which is put into lateral compression by pressure from a coin on any of the movable arms, and thus no force is transmitted to the relay armature; the mechanical locking is safeguarded in the same way. It is arranged that no two arms can be moved simultaneously, so that it is only possible to insert one denomination of coin at a time. The movement of any one of these arms by the insertion of a coin lifts the pulser cams in readiness for coin signalling and also positions the coin-pulser spring-set opposite the appropriate cam. This spring-set is normally positioned against the sixpenny cam to minimize the work to be done by the smallest coin. Once the coin has passed the movable arm it is checked on a coin tester similar in principle, but of improved design, to that used in existing coin-boxes. Where the use of counterfeit coins is prevalent a milling detector can be fitted to either or both of the silver-coin testers. After successfully passing the tester, the coin operates the mask contacts (see Fig. 4) to remove the short-circuit from the pulser, and then falls into the cash compartment.

The pulser mechanism has six cams linked to a dial-type governor in such a way that they can be quickly raised but will fall steadily during the 2-second period of the operational cycle. Should the pressure on the coin be relaxed during insertion a double-acting ratchet

supports the cams at the point reached to avoid lost ground. This ratchet also prevents the cams being re-lifted once they have started their downward swing.

During each operation of the pulser, four spring-sets CP.ON1, CP.ON2, CP.ON3 and CP are actuated. A fifth spring-set, the MASK, is operated by any coin which successfully passes the coin tester and is reset as the cam bank comes to rest. CP.ON1, CP.ON2 and CP.ON3 are associated each with its own cam and operate in the same sequence independently of the value of coin inserted, but CP is mounted on a pivoted carriage and is positioned, during coin insertion, opposite the appropriate cam to produce one, two or four pulses. An interval of 900 ms is allowed between the fall of a coin and the commencement of pulsing to ensure that a slowly moving coin has had time to operate the mask. (See Fig. 5.)

The amount of energy available to operate the pulser is derived from the insertion of the coin, and it must be limited if the coin-insertion pressure is to be kept to an acceptable figure. For this reason the distance through which the cams can travel, and hence the length of a lobe on a cam, is rather short, and the precision with which the spring-sets can be adjusted relative to the cams must be high if the required accuracy of timing is to be obtained. It is arranged, therefore, that the engagement of the spring-sets with the cams can be adjusted accurately by means of rockers, and the relative timing of the spring-sets controlled by positioning the operating levers by means of spring-loaded screws giving a fine adjustment.

#### *Maintenance*

The coin-box equipment has been designed with the maintenance aspect very much in mind and is of unit

construction throughout. Thus, any part of the casing which becomes worn or damaged in service can be replaced in the field without removing the backplate or the permanent wiring. The two main units of the mechanism are the coin acceptor and the pulser. It is not anticipated that the pulser will normally have parts replaced in the field but the coin acceptor has a readily detachable coin-runway assembly which can be changed if it becomes faulty. The front of the reject-coin guide-tube is detachable so that, for example, any jam caused by interference with the reject-coin slot can be readily cleared by the maintenance staff. It is thought probable that any fault on the pulsing unit will be dealt with at a coin-box overhaul centre, after the whole mechanism has been jacked out and a spare one inserted.

A testing kit has been prepared for use in an overhaul centre, and a multi-point test jack and plug are provided at the base of the pulsing unit to isolate and give access to the various circuit elements. The kit will enable the overall time of the fall of the cams to be set up correctly, and the correct positioning of the spring-sets to be obtained.

#### ACKNOWLEDGEMENTS

Acknowledgement is made to Messrs. Associated Automation Ltd., the development contractors for the new coin-box.

#### *References*

- <sup>1</sup> WALKER, N. Periodic Metering. (In this issue of the *P.O.E.E.J.*).
- <sup>2</sup> HEPTINSTALL, D. L., and RYAN, W. A. Metering over Junctions. (In this issue of the *P.O.E.E.J.*).
- <sup>3</sup> SPENCER, H. J. C., and WILSON, F. A. The New, 700-Type Telephone. *P.O.E.E.J.*, Vol. 49, p. 69, July 1956.