

Not to be shown outside British Telecom

“AMBASSADOR” TELEPHONES



AMBASSADOR TELEPHONES

These guide notes have been designed to assist Field Staff with the installation and maintenance of AMBASSADOR. To gain maximum benefit from them they should be read completely, by both Installation and Maintenance staff.

DIFFICULTIES

THQ relies to a large extent on the A646 procedure to show up problems which staff experience with items of equipment. Please take advantage of this procedure to inform THQ of difficulties so that corrective action can be taken.

T1 E1 A0091 describes the A646 procedure fully.

Contents	Page
1. General Description	1
2. Facilities	5
3. Installation	13
4. Telephones	19
5. Plan Numbers and PBX Extensions	23
6. Maintenance	27
7. Diagrams	33
8. Converted Bells & 8700 Type Teles	41
9. List of Spare Parts	42

Designed & Printed by BT Reprographics

1. General Description

Ambassador telephones incorporate improvements in design to improve customer quality of service, especially regarding noise complaints, and to uprate reliability to best international standards. The enhanced features include:—

- i. Handset 16 uses a “linear microphone” (Microphone Inset ...21A), not a carbon granule type.
- ii. Shrouded gravity switch springset with twin “wiping” contacts. The operating linkage is arranged to prevent a calling signal to line when the tele cover removed.
- iii. Internal “straps” have push-on connexions.
- iv. Easy lift-off cover is secured by two captive screws and incorporates a carrying handle and a flip-lid personal directory. The gravity switch plunger is retained in the case.
- v. Choice of three positions for line cord entry.
- vi. Improved flat cordage with plug and socket terminations accessible without removing the tele cover.
- vii. Handset and line cords plug into sockets in the telephone. The line cord also plugs into a socket at the line terminating jack.
- viii. Battery (when fitted) accessible without removing the tele cover.

Suffix R – earth recall

Suffix RR – “timed break” recall (The switch gives a timed break pulse to line when operated, this is used on MF Main Exchanges to provide “Register Recall”.

Suffix AR – “alternative” recall, (supplied as “timed break” but by means of strapping changes can be altered to “earth recall.

e.g. Tele 8200R – a SC tele wired for “earth” recall.

- ix. Two versions, “Basic” and “Developed” are available. The “Developed” version is supplied in two variants, there being minor differences due to manufacturer.

Two similarly styled versions of the telephone are:—

1 BASIC VERSION

Basic Version (Dial), (figure 1) equipped with a standard dial.
or,

Basic Version (Push Button), (figure 2) which may be for either self contained loop-disconnect pulsing (SC) or for multi frequency (MF) signalling

These telephones have the following titles:—

Tele 8100 – Dial version (fig 1)

Tele 8200 – SC (fig 2)

Tele 8300 – MF (fig 3)

these are superceded by:—

2 DEVELOPED VERSION

The “Developed” versions are produced in two variants, made by different manufacturers. Developed versions are:—

Tele 8202 – SC

Tele 8302 – MF

ALSO AVAILABLE IS THE TELE 8220. This is an SC 10 address repertory dialling version.

The differences between Basic Version and Developed Version and variants of Developed versions will be explained as necessary in the appropriate sections of this book.

Other variants of the developed telephone may become available later.

RECALL

All these type numbers are given a suffix to indicate the type of recall for which the telephone is used.

Suffix R – earth recall

Suffix RR – “timed break” recall (The switch gives a timed break pulse to line when operated, this is used on MF Main Exchanges to provide “Register Recall”).

Suffix AR – “alternative” recall, (supplied as “timed break” but by means of strapping changes can be altered to “earth” recall. e.g. Tele 8200R – a SC tele wired for “earth” recall.



Fig. 1. Basic Version, Dial. Tele 8100

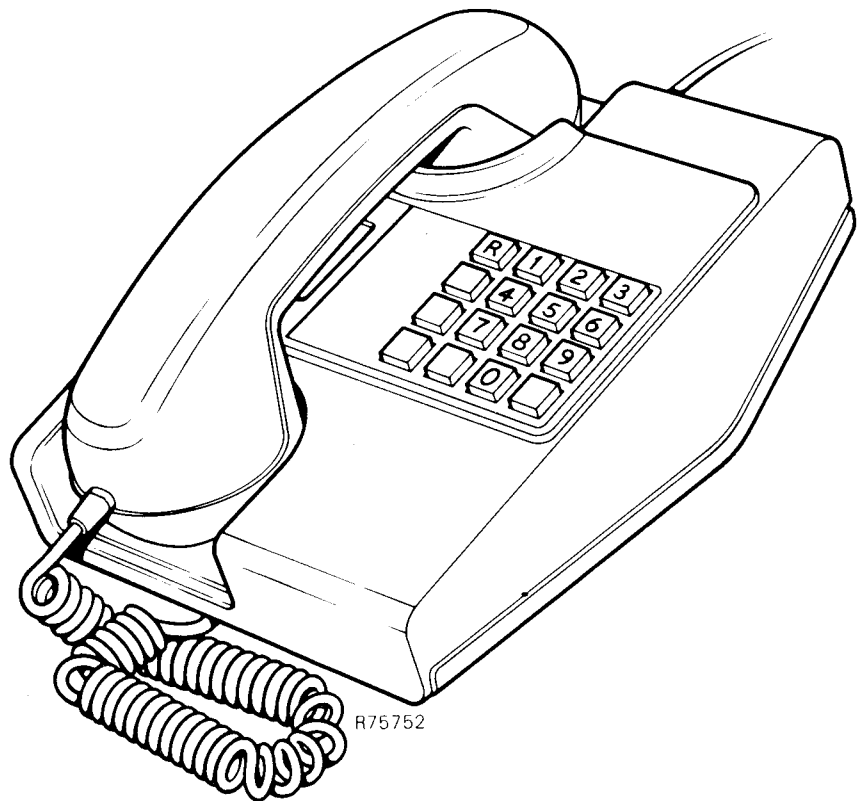

Fig. 2. Basic Version, Self Contained. Tele 8200



Fig. 3. Basic Version M.F. Tele 8300

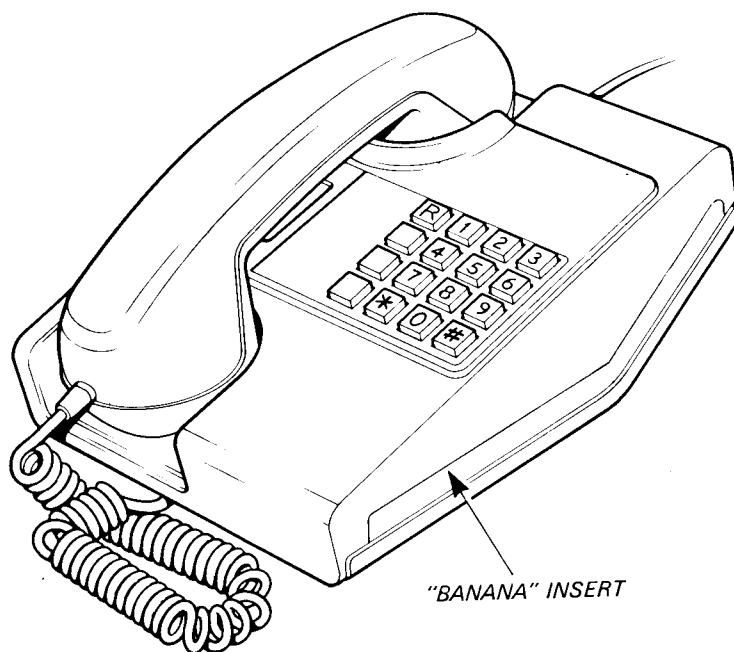

Fig. 4. Developed Version M.F. Tele 8302

The noticeable difference with a "Developed" version is the "Banana" insert in the righthand side of the cover as shown in fig 4.

This provides an attachment for "add on" units such as a loudspeaker unit, SPM unit, answer set, answering recording set, etc.

2. Facilities

The telephones in the Ambassador range have most of the facilities associated with the standard range of telephones. The table shows their range of use.

TELEPHONE	FACILITY/USE								
	DIAL	S.C.	MF	DEL (exclusive service only)	Phone Socket Universal	2 wire PBX extension with or without recall	'C' wire PBX extension	10 Address repertory dialling	'B' end of Plan 105/107 external extension only
8100	✓			✓	✓	✓	✓		✓
8200		✓		✓	✓	✓	✓		✓
8202		✓		✓	✓	✓	✓		✓
8220		✓		✓	✓	✓	✓	✓	✓
8300			✓	✓	✓	✓	✓		✓
8302			✓	✓	✓	✓	✓		✓

NOTE AMBASSADOR telephones should not be used together with low impedance Special Range Telephones on the same installation.

Bell Volume Control – The telephones are provided with a mechanical volume control for the bell.

Telephones 8xx0

Positions loud, medium, soft and off. In the "Off" position a microswitch disconnects the bell and the hammer is locked in position.

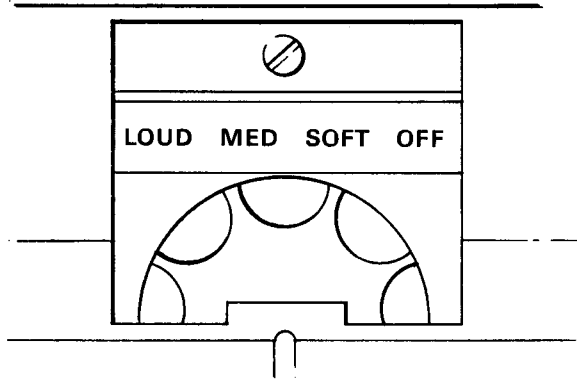

Fig 5

To switch to "off" turn the control from "Loud" through "Soft" to "Off".

Telephones 8xx2

The control on these teles has the positions "Soft", "Loud" and "Off". To switch the bell off it is necessary to turn the control to "Loud" and pull the extended tag forwards. The bell is disconnected by the operation of a microswitch.

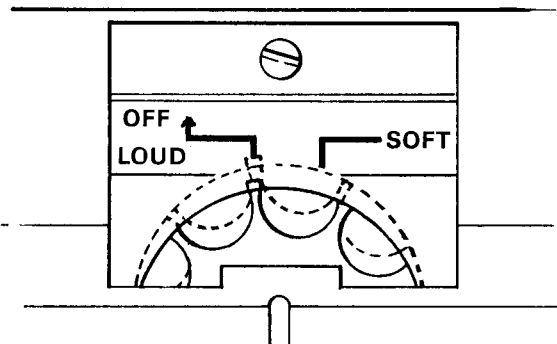

Fig 6

Dotted line shows position of control wheel when in the "Off" position. Solid line shows control switch to "Loud".

Tone Caller

Where a tone caller is used in place of the bell the volume control has the positions "Loud", "build-up", "soft" and "off". In the "off" position the tone caller is disconnected.

Handset No 16 –

All Ambassador telephones use the Handset No 16. Early versions use the Handset 16A, later versions use the Handset No 16B, which is distinguishable from the Handset 16A by its "Pepper Pot" earpiece and a small recess under the earpiece, see Fig 7.

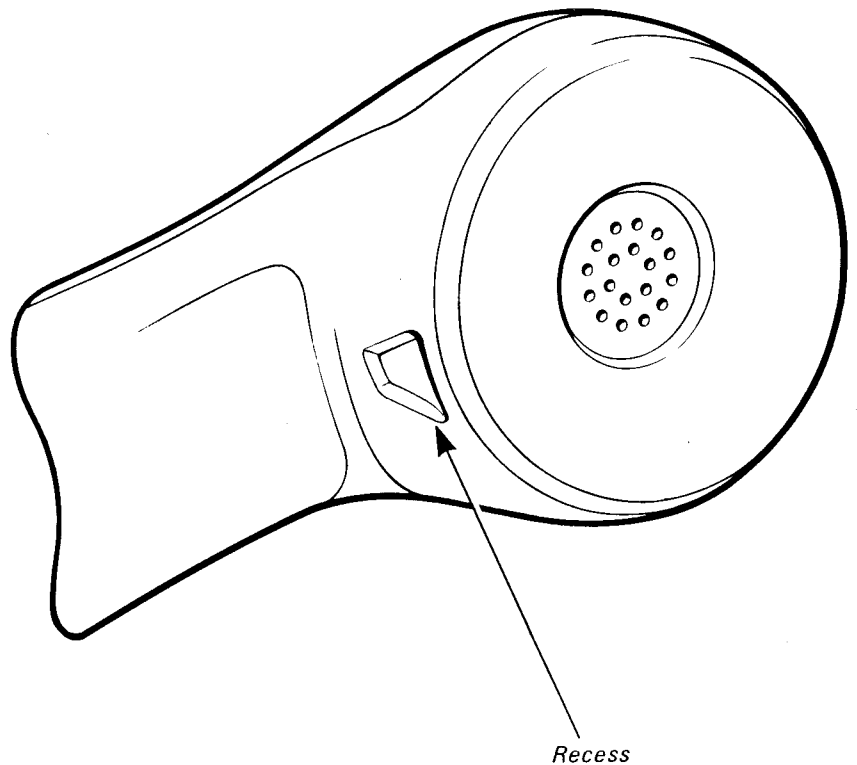

Fig 7. Earpiece of Handset No. 16B

Also available are 3 facility handsets, these are of similar appearance to the Handset No 16B but have the components required for the facility mounted within the earpiece, the facilities are:—

An amplified handset with volume control at the rear of the earpiece. Handset No 16C.

A neon indicator at the rear of the earpiece to give a visual indication of an incoming call. Handset No 16D.

A locking/non-locking on-off switch used as a transmitter cut-out. Handset No 16E.

These handsets are shown in Fig 8.

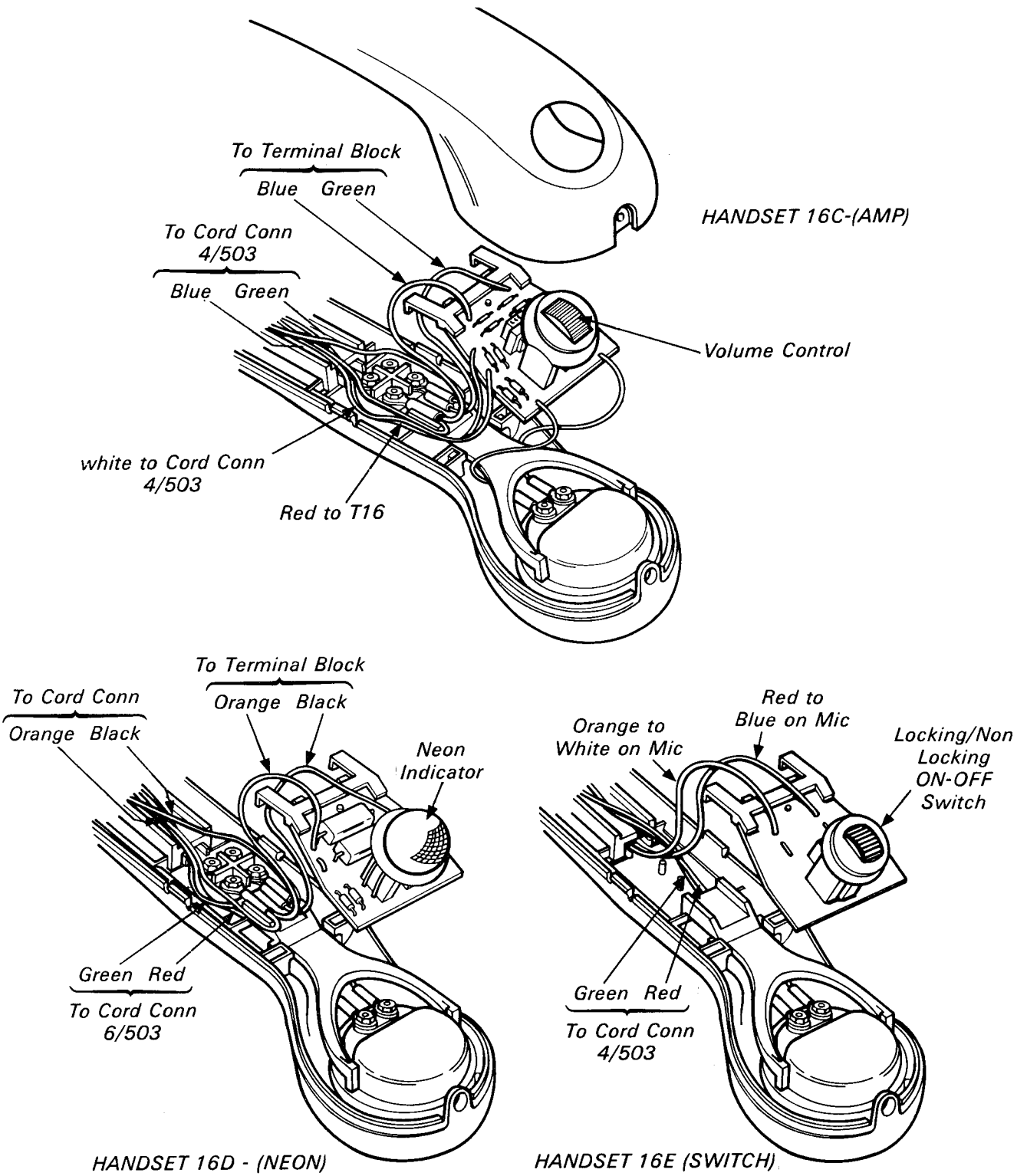

Fig 8. Handsets Nos 16C, D and E

Number Label – At the left-hand side of the tele case is a recessed carrying handle. Above this is a lift-up flap, the lid of which carries the number label. Under the flap is a “personal directory”, uncovered when the flap is lifted. To change or insert a number label, lift the flap and press on the extended ends of the label cover, this ejects the transparent cover pack into place.

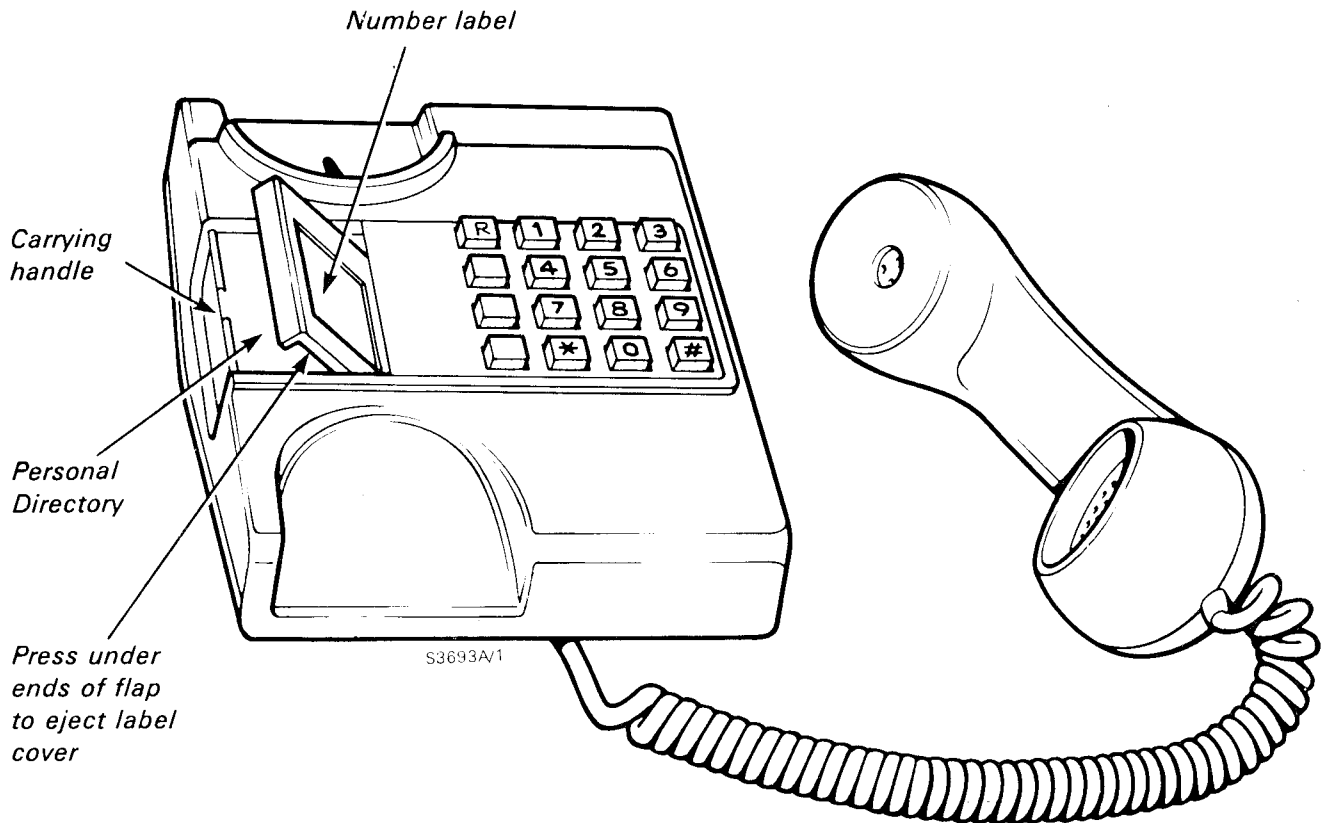

Fig. 9

Keypad – To prevent the depression of spare keys, locking clips should be fitted, these are nylon clips shaped like a square □, (Part 1/DCL/580). The tele cover must be removed to allow the locking clips to be “snapped” under the spare buttons. Do not remove the button top to fit a locking clip, it will be found very difficult to replace the button correctly. To remove a clip, pull off the button top, remove the clip and replace the button.

10 Address Repertory Dialling

Telephones 8200 have the additional facility of a 10 address repertory dialling unit. Up to 10 exchange line numbers each of up to 18 digits can be stored, one under each button from 1 to 0 of the push button dial unit. On these telephones the row of buttons to the left of the push button dial are marked R.T.P. down as in Fig 10.

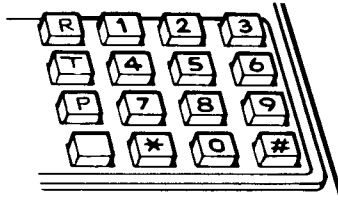



Fig. 10 Typical dial unit keypad

The facilities offered by these telephones are:—

REPEAT LAST NUMBER MANUALLY KEYPED



The last number **manually** keyed can be repeated an unlimited number of times by lifting the handset and on receipt of exchange dial tone depressing and releasing button  twice.

OPERATION AS A CALLMAKER

10 exchange line numbers, each of up to 18 digits can be stored and called automatically.

To store a number

Lift the handset and place it to one side, both hands are needed to operate the correct buttons for this operation.



- i. depress and **hold down** button 
- ii. depress and release the digit button under which the number is to be stored, say digit 3
- iii. “key in” the number to be stored, in the normal fashion, say 01-234 5678
- iv. release button 
- v. replace the handset.

In this example exchange line number 01-234 5678 is stored "under" digit button 3. Numbers containing up to 18 digits as for international dialling numbers can be stored.

To send a stored number

- i. lift the handset and on receipt of exchange dial tone depress and release button 
- ii. depress and release the digit button under which the required number is stored.

To erase a stored number

- i. lift the handset and place it to one side
- ii. depress and hold down button 
- iii. depress and release the digit button under which the number to be erased is stored.
- iv. release button 
- v. replace the handset.

To change a stored number

It is not necessary to erase a stored number before replacing it with a new number. Keying a new number into the store under a digit button already used replaces the previous number in that store.

Batteries

10 address repertory dialling versions require an internal battery to maintain the stored programmes. The battery used depends on the manufacturer of the telephone.

Tele 8220 GEC manufactured (8220 GEN.../...) requires a Battery Dry No. 102.

Tele 8220 TMC version (8220 GNA .../...) requires a Battery Secondary No. 33.

3. Installation

General – Ambassador telephones should be installed following the instructions for “Phone socket” type installations.

Mountings

The “Basic” versions are intended to be used as free standing or “table mounted” only. The “developed” versions may be either table mounted or wall mounted. To provide a wall mounted Ambassador a Bracket Telephone No 20D supplied with an “Ambassador Wall Mounting Kit” is used.

Wall Mounting

The Bracket Telephone No 20D is designed either to hold an Ambassador telephone permanently, with the telephone clipped to the bracket, or to provide a shelf on which the telephone may be placed when required, known as a “Casual” mounting. A short (150mm) line cord may be fitted when the telephone is to be clipped to the bracket.

Fitting the Bracket

Before fixing the bracket to the wall it must be decided whether or not the telephone is to be clipped to the bracket:

If the telephone is to be clipped to the bracket to provide a “permanent” mounting clips 1 & 2 (see fig 11) must be attached before the bracket is screwed to the wall. If a “casual” mounting is required only clip 2 should be fitted. Later kits will have clip 2 already fitted.

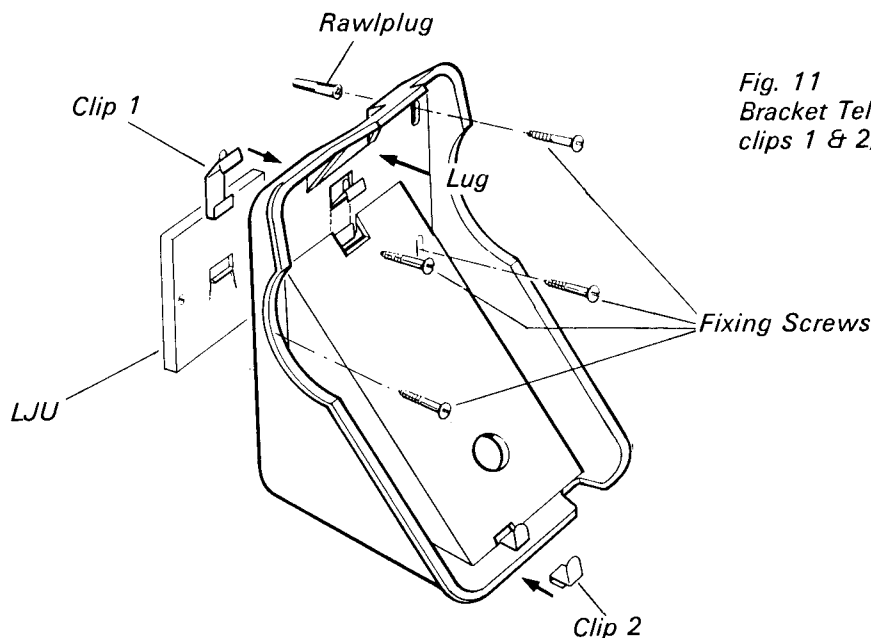

*Fig. 11
Bracket Telephone No 20D showing
clips 1 & 2, fixing screws and LJU*

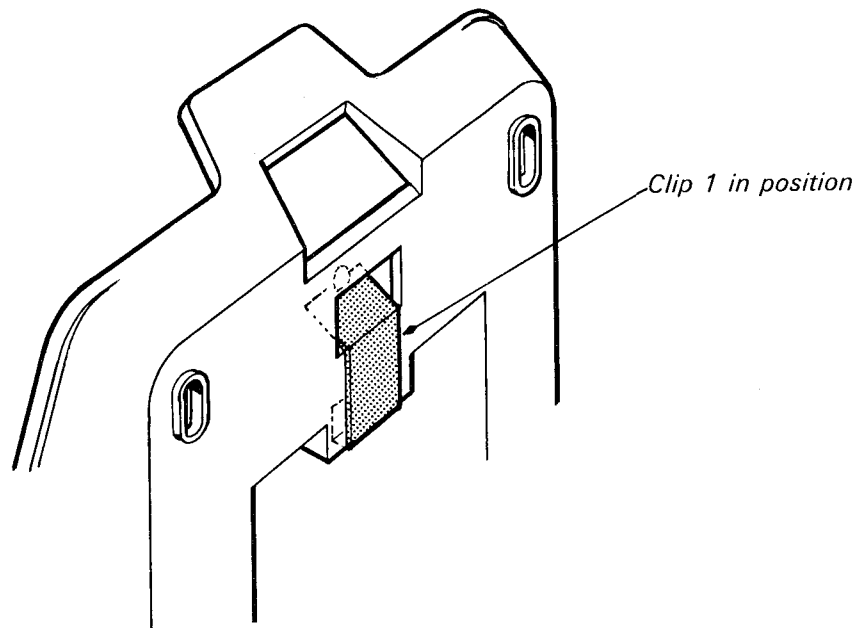
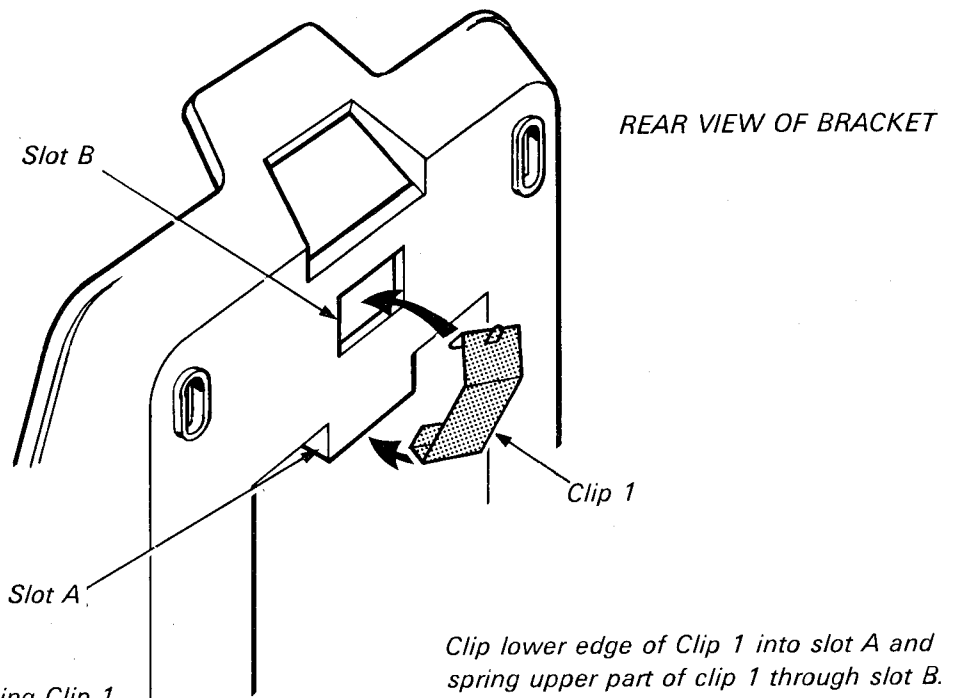

Fig. 13 Clip 1 in position

REAR VIEW OF BRACKET

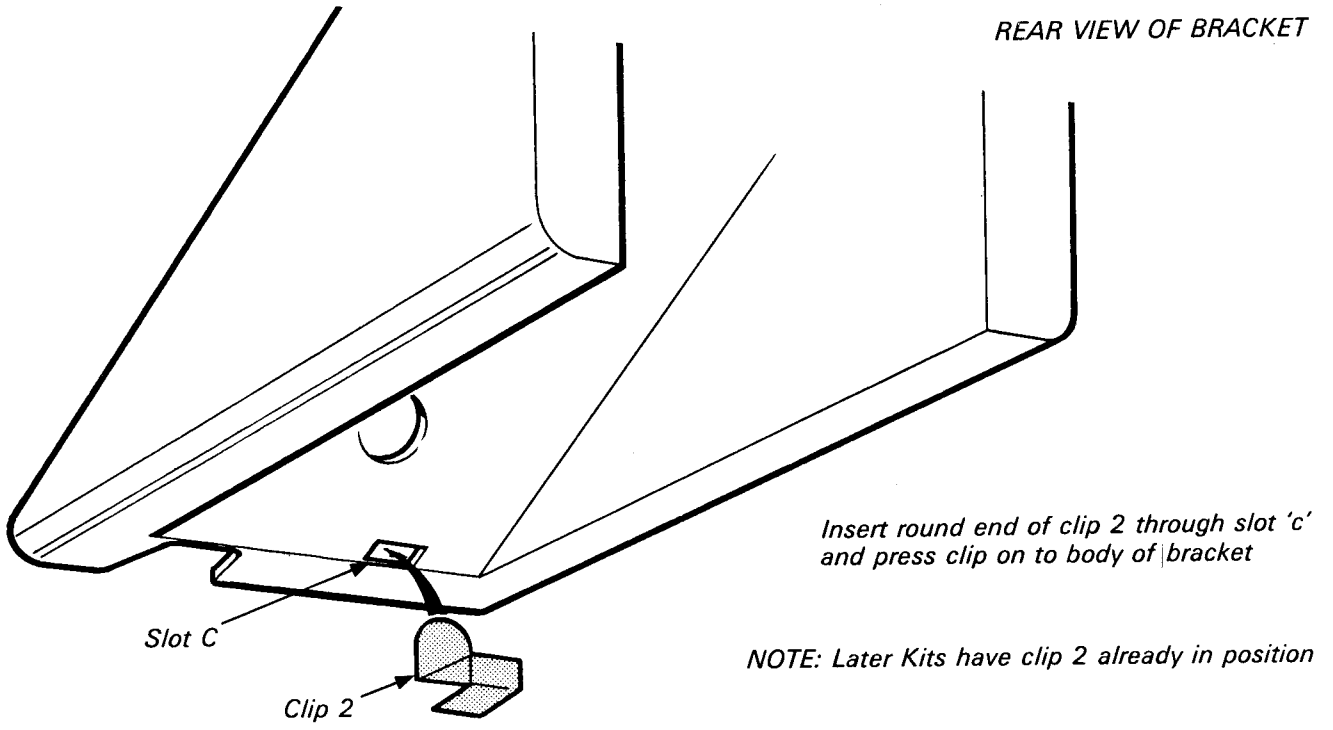

Fig. 14 Inserting Clip 2

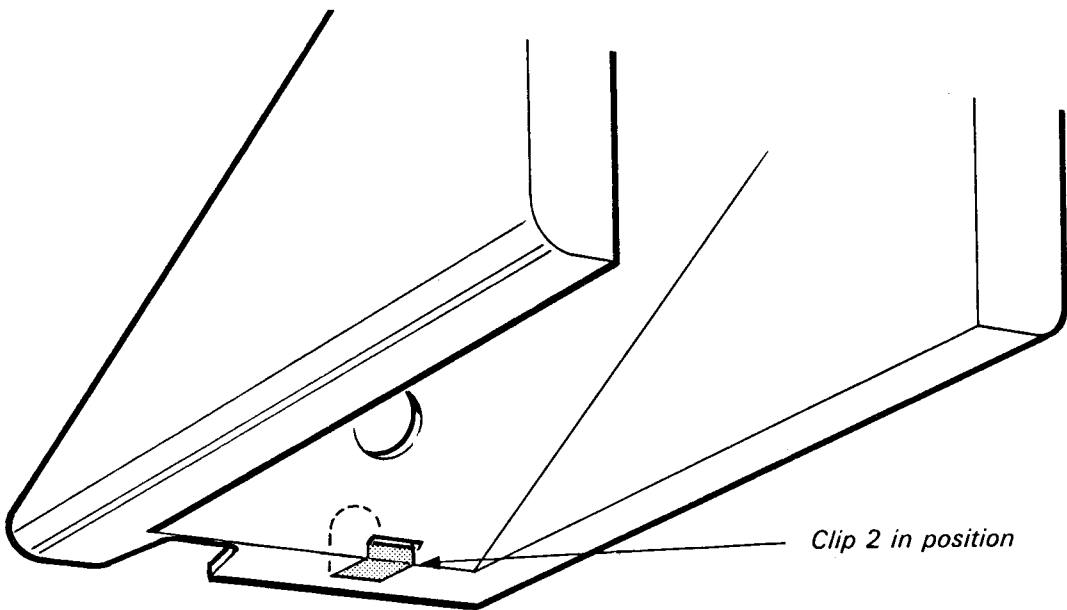

Fig. 15 Clip 2 in position

Figures 12, 13, 14 and 15 show the positions for clips 1 and 2. The bracket should be offered to the wall (to cover the LJU if a permanent mounting is required) and the position of the fixings marked through the bracket on to the wall.

The wall must be drilled with a No 10 or 5.5 mm drill to a sufficient depth to allow the plugs provided with the kit to be fully inserted. The fixing screws are inserted, the bracket levelled and the screws fully tightened.

After connecting the line cord of the desired length to the telephone and the LJU the telephone is placed on the bracket.

To fit the telephone to a "Permanent" wall mounting the lower end of the telephone is placed so that clip 2 on the bracket enters Slot A (see fig 16) on the telephone base. The telephone is then hinged back so that the extended lug on the bracket enters slot B on the telephone case (see fig 16). When the telephone is pressed firmly into place clip 1 on the bracket will snap into place to hold the telephone to the bracket. To fit the telephone in the casually mounted mode, hook slot B in the telephone case (fig 16) over the extended lug on the bracket and engage clip 2 in to slot A. As clip 1 has not been fitted, as previously mentioned, the telephone may be lifted on and off the bracket as required.

NOTE The Handset 16A is not suitable for use with a wall mounted "Ambassador".

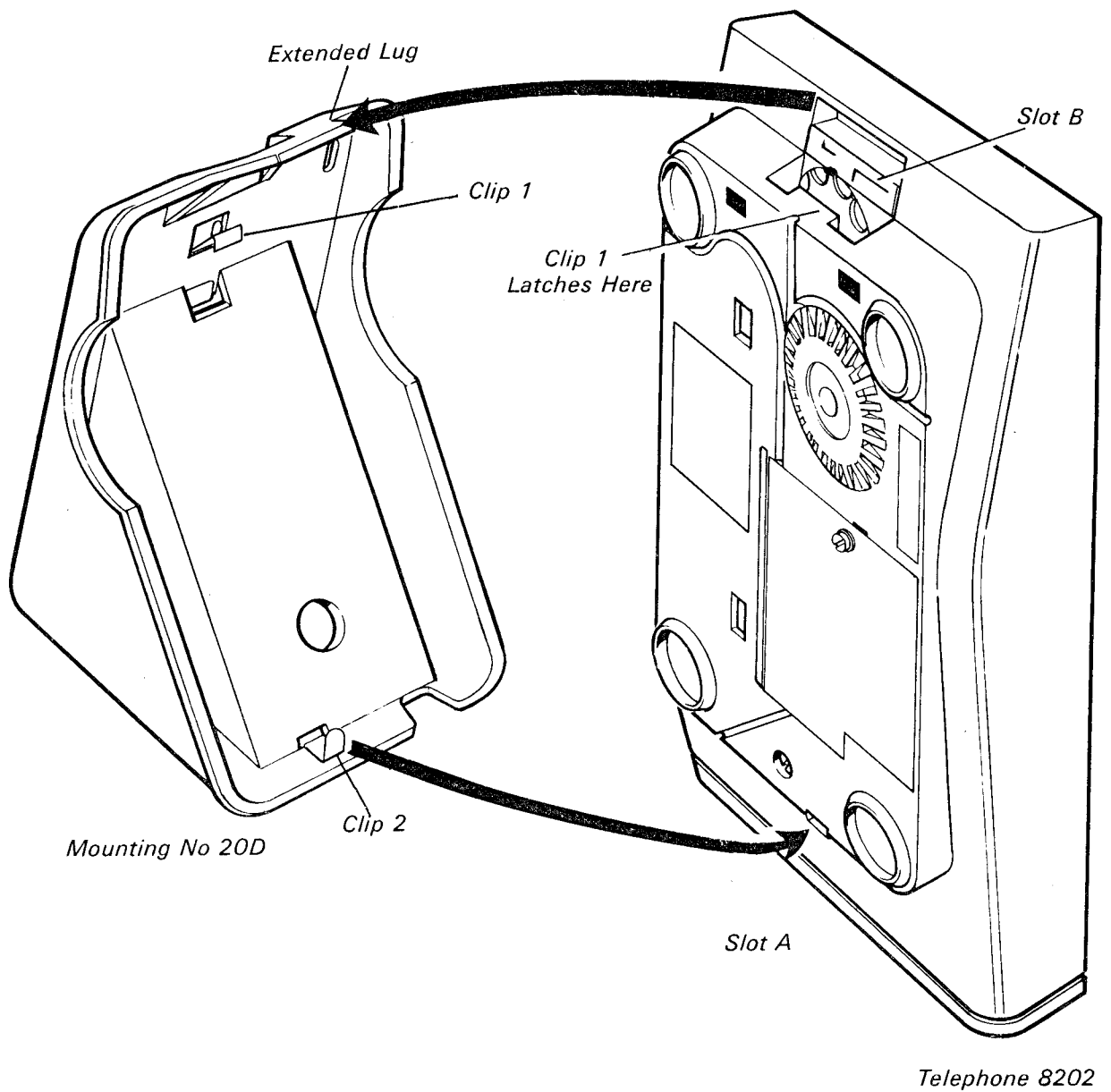

Fig 16 Fitting Telephone to a Permanent Wall Mounting

4. Telephones

The two versions of the "AMBASSADOR" telephones look similar but can be identified by differences in the cover and the base.

Cover

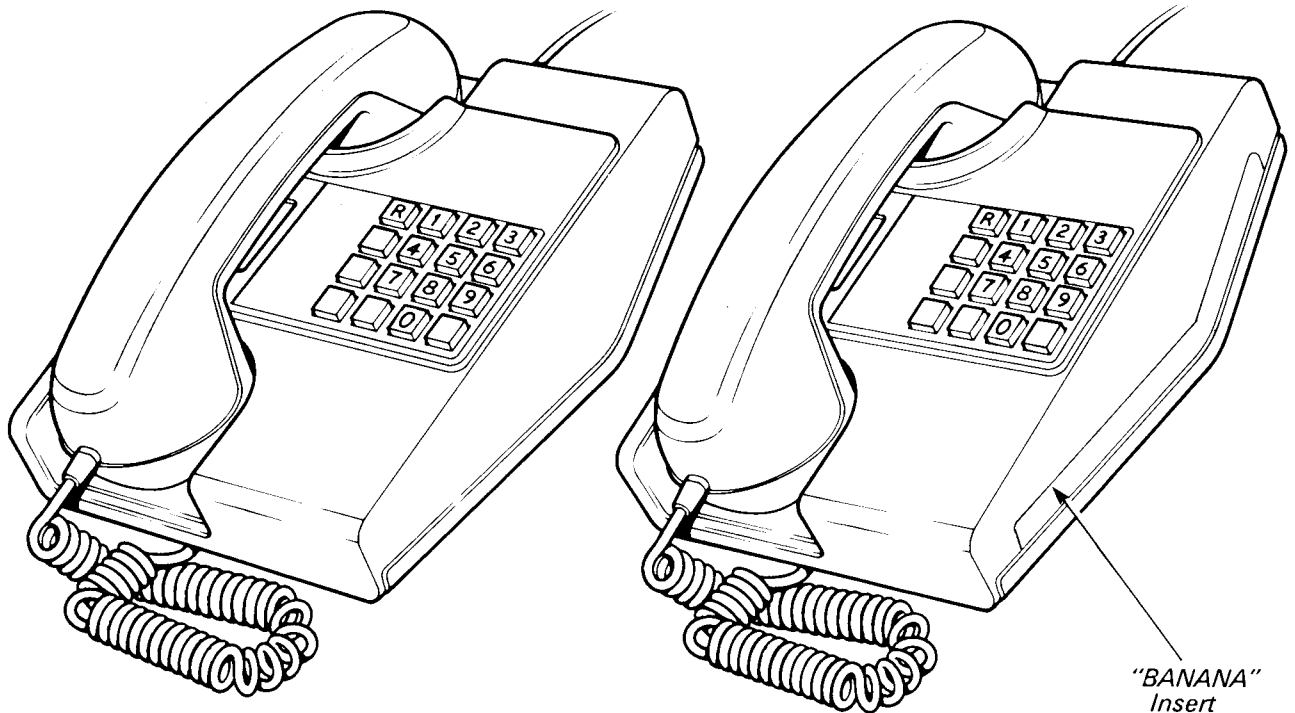

Fig. 17 BASIC VERSION

Fig. 18 "DEVELOPED" VERSION

The "Developed" version has a "banana" insert in the right-hand side of the case, this is removed to allow the fitting of various "add-on" units.

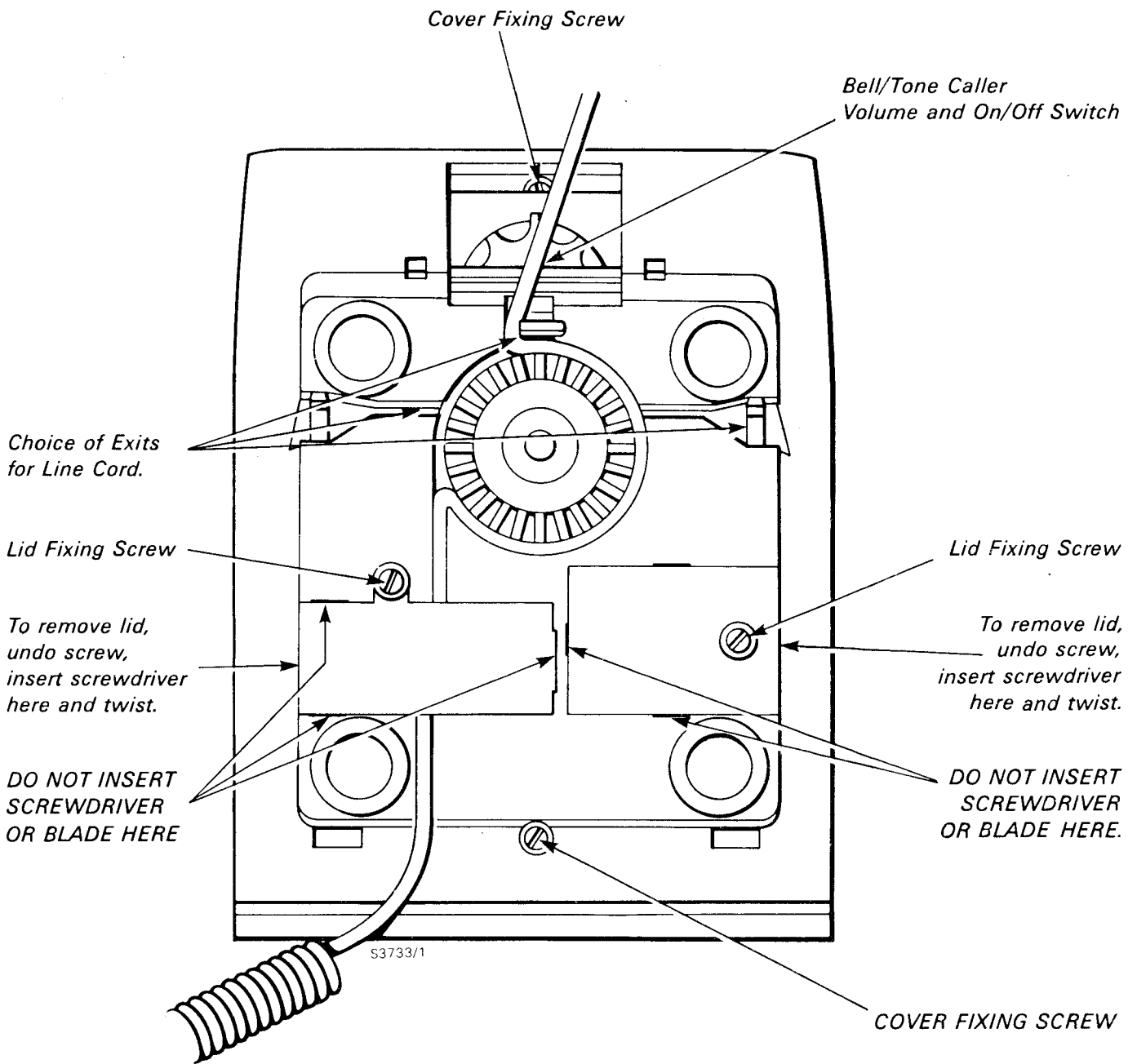

Fig. 19 Base of "Basic" Telephone

The Battery Box and Cord Socket Box lids are snap closures with security screws. To remove the lids first unscrew the captive fixing screw and then insert a screwdriver between the indentation in the edge of the lid and the base of the tele, at the points indicated in fig. 19 Twist the screwdriver to ease off the lid.

The three thin slots between the edges of the lids and the base have been formed during the moulding process and **must not** be used to assist in removing the lids or damage to the snap fixings will result.

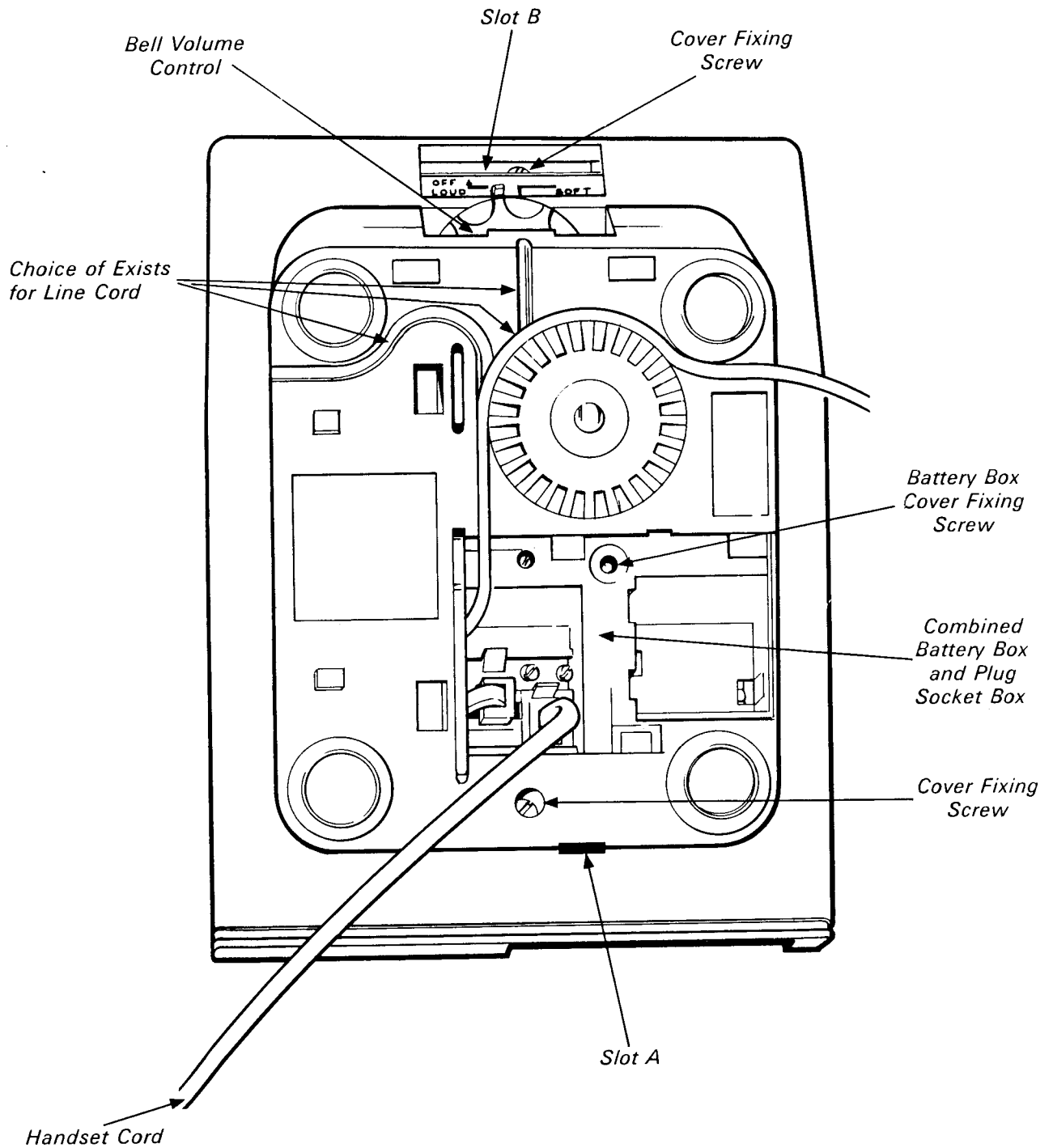

Fig. 20 Base of "Developed Version"

The combined battery and cord socket box lid is a snap closure held with one captive securing screw. To remove the lid unscrew the screw fully and using the screw as a handle pull the lid off.

5. PLAN NUMBERS AND PBX EXTENSIONS BASIC TELEPHONE

The diagrams for C-wire recall (fig. 31) and for the "B" end of Plan 105 or 107 external extension (fig. 33) refer to "T-wires", these are insulated wire straps, one end permanently connected to the printed circuit board (PCB) and the other end to a miniature socket connector which allows connexion to one of a number of post terminals. These connectors are fragile and pliers must not be used to grip them, by design it should be possible to move them when necessary using fingers only. Notice that where more than one connexion has to be made a number of posts are grouped together with the same tele terminal number (fig. 21)

When "T-wire" changes have to be made it is first necessary to remove the cover of the instrument (see fig. 19) then to remove the "spider" carrying the Push Button Unit (PBU). Notice it is not necessary to remove the transmission board from the base. Referring to figs. 22 and 23 the PBU is connected to the transmission board by a ribbon cable, the plug of which is keyed to ensure correct location in the socket. The PBU is supported on the spider mounting which clips to the transmission board. They may be separated by gently sliding the signalling board towards the bell and then lifting it clear. It is not necessary to unplug the ribbon cable when separating the boards.

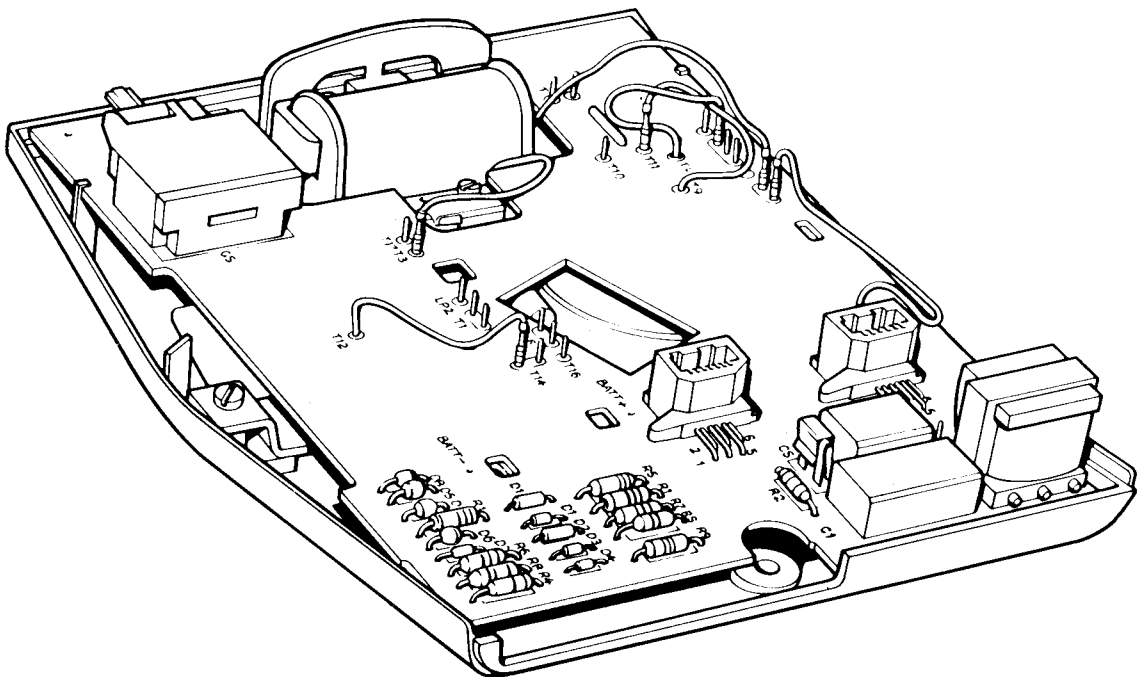

*Fig. 21 "BASIC" Telephone
Transmission Board showing Movable Straps and Terminal Posts.*

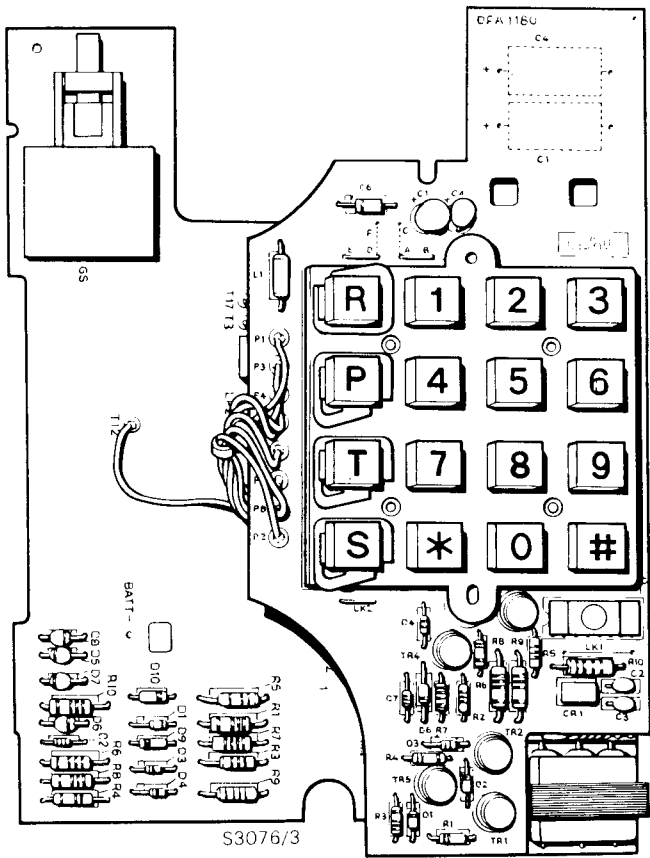

Fig. 22 Push Button Unit (PBU) in place on Transmission Board.



 SLIDE PBU 1/4"

Fig. 23 PBU lifted clear.

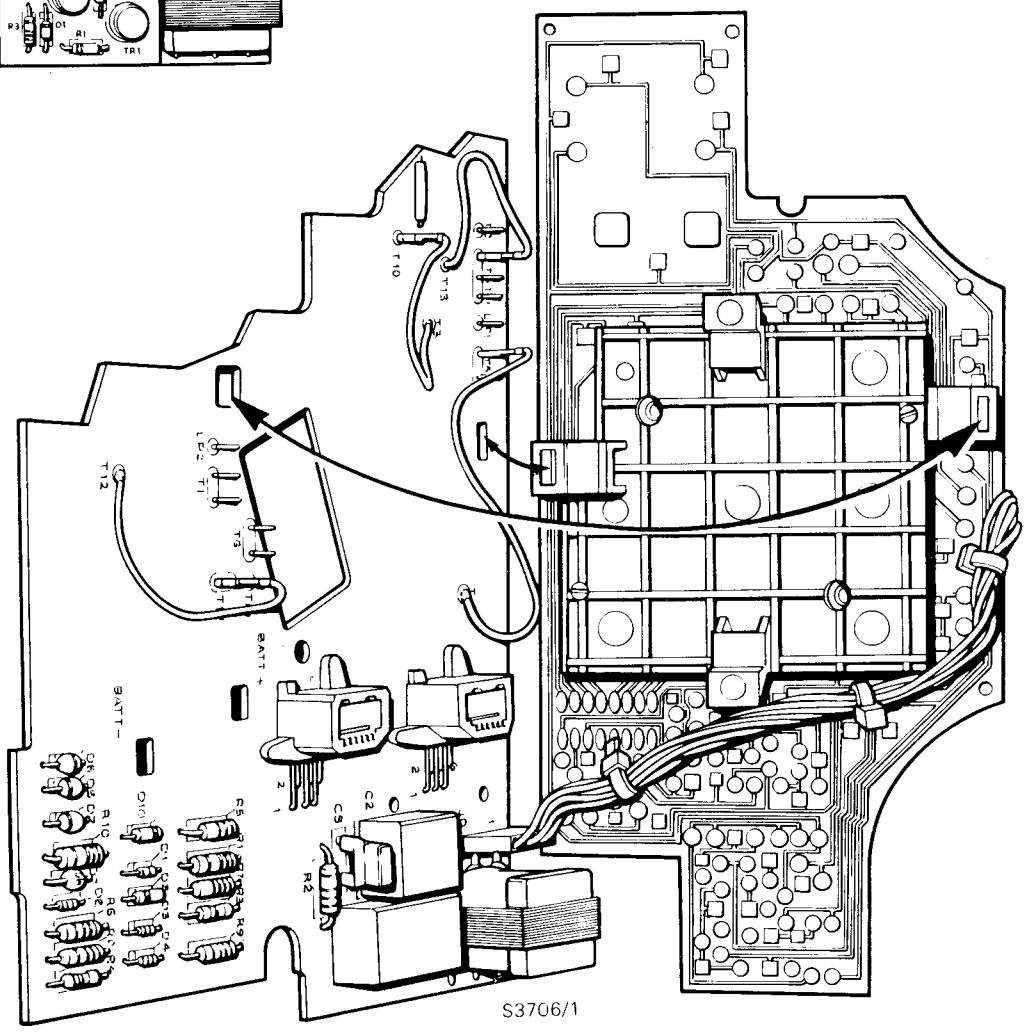

DEVELOPED VERSIONS

GEC variants can be identified by the code 8xxx GEN/1 marked on the base.

Internally they may be recognised by having only one Printed Circuit Board (PCB) with the keypad as a unit connected by a ribbon cable. (Fig 24). These telephones are wired to the same diagrams as the basic version and diagram Fig 35 should be used.

The movable "T straps" are grouped in the lower right hand corner of the PCB. To reach these more easily the keypad should be lifted to one side, slide the keypad forwards and lift, there is no need to disconnect the ribbon cable.

Note that terminals T5 and T6 are duplicated and are mounted with the main group of terminals and also near to the right of the bell coil. This is to avoid long straps within the tele.

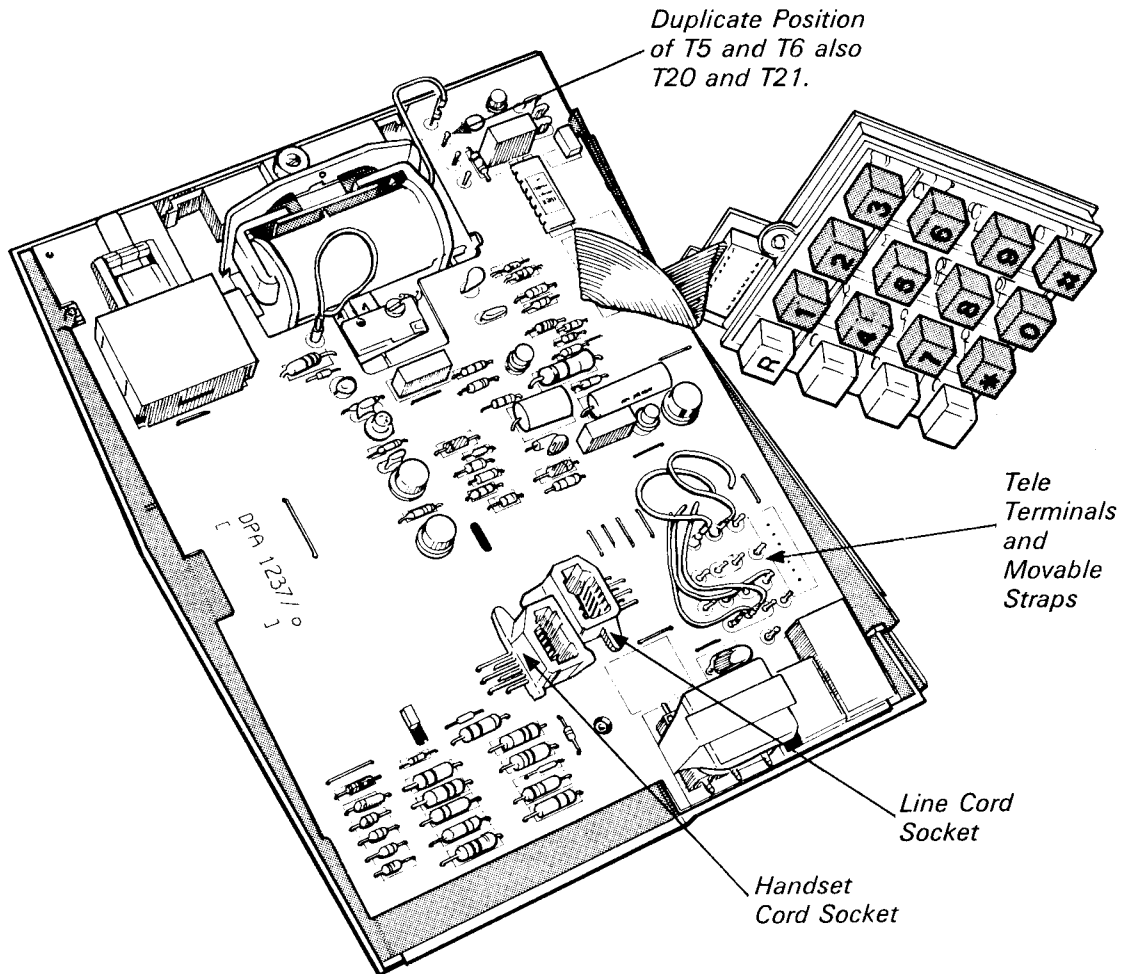

Fig. 24 GEC Telephone (internal arrangements)

TMC variants are marked with the code 8xxx GNA/1.

These telephones have two PCBs rather like the "Basic Version", but the connexion between the Transmission board and the Signalling board has been moved to the left hand side of the keypad. The internal circuitry of this telephone is arranged differently and the moveable connexions used to provide recall etc are in the form of "two position" plugs, see Fig 25, a link or plug being connected between pins 1 and 2 or 2 and 3 depending on the position of the plug.

The diagrams for TMC telephones are shown as Fig 34 in the diagram section.

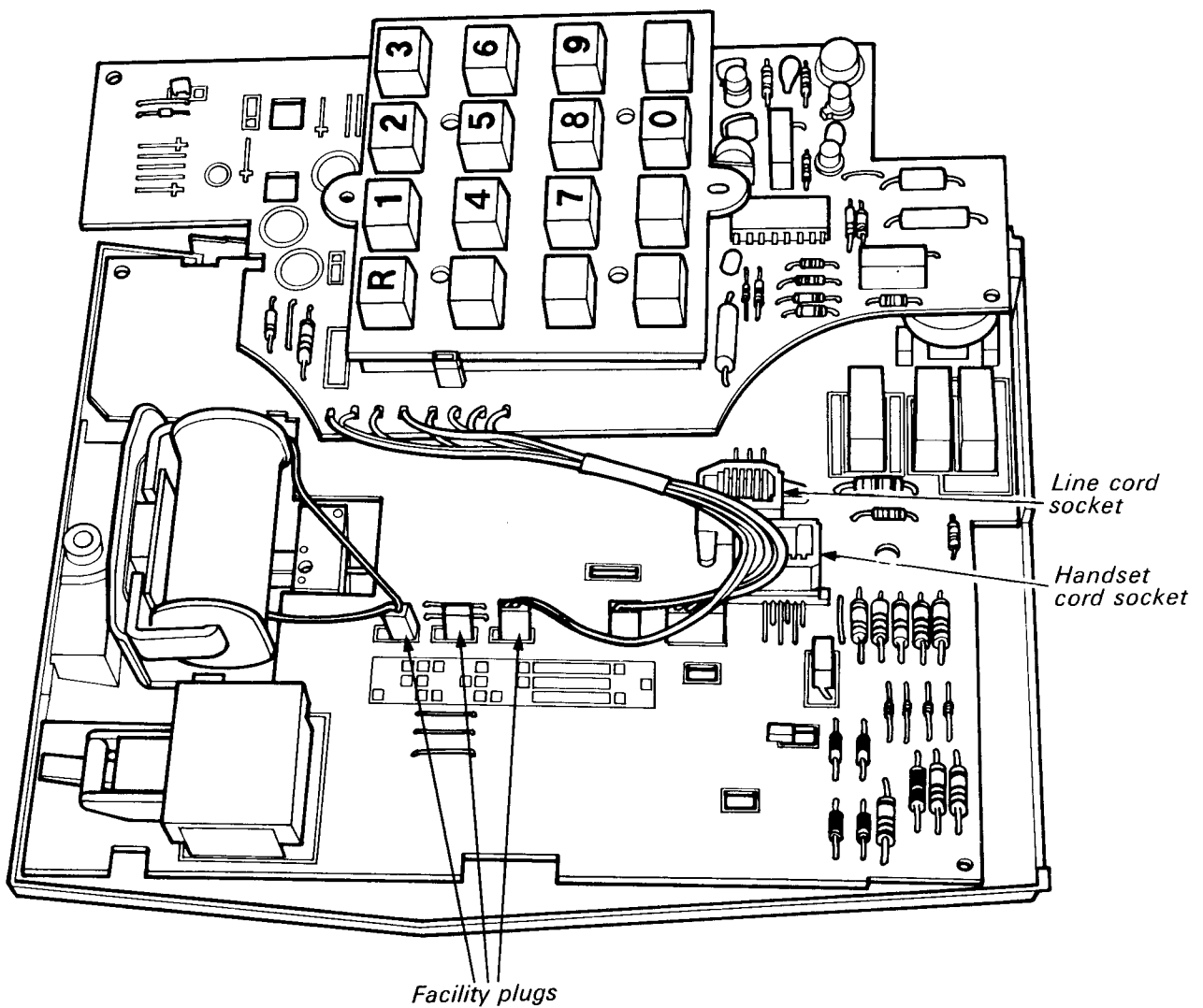

Fig. 25 TMC Telephone (internal arrangements)

6. Maintenance

General – Maintenance staff are advised to read the section on Installation.

Maintenance of the Ambassador telephones is restricted to changing the replacement parts listed in Table 2 as required or to changing complete instruments.

In the event of a Push Button Unit (PBU) fault the PBU may be changed with one from a replacement telephone if the only available replacement telephone is the wrong colour.

Dismantling and Reassembly – Normally maintenance will not need the removal of the telephone cover. If exceptionally this is required refer to page 19 and to figs. 19 or 25.

The gravity switch mechanism is reverse acting and so like a Trimphone does not present a calling signal to line when the tele cover is removed. The springsets have twin wiping contacts and are completely enclosed, no adjustments are required. The handset cord and the line cord plug into sockets recessed in the tele base. Access to the plugs and sockets is gained by removal of the narrower of the two cover plates, but refer to the notes for fig. 10 before attempting to remove the cover. You will find that considerable force is required to remove this cover, this is because of the position of the “snap-on” lugs on the cover.

Radio Interference – In some areas Ambassador telephones may pick up radio signals usually from high power medium wave transmitters. These cases should be referred to the local Radio Interference group who may seek advice via their Regional Service Group. An RFI filter is available, this is similar in appearance to a BT80A. Full instructions for fitting the filter are included with the filter.

Testing Continuity of Bell Circuit – the zener diodes in series with the telephone bell have a threshold voltage (ie it starts to conduct) of 3.3V. Their purpose is to prevent a shunt path being connected across the speech pair when the gravity switch springs GS2 operate and connect resistor R10 across the bell. They also form part of a “pulse shaper” network and “spark quench” circuit designed to ensure correct shaped pulsed are sent to line when keying or dialling out. To test the continuity of the bell circuit, eg between jack points 3 & 5, a Meter Multirange 12A must be switched to the 100R scale or the 0.2M Ω scale depending on the type of meter.

The Bell Unit 8001 has a mechanical volume control, giving a range of control from loud to soft and off. In the off position a micro-switch disconnects the bell, see fig. 26. Where a tone caller is used in place of the bell the volume control has the positions loud, built-up, soft and off. In the off position the tone caller is disconnected.

The gongs of the Bell Unit 8001 are set during manufacture to conform to an operating current value, the gongs **must not be moved** for any purpose.

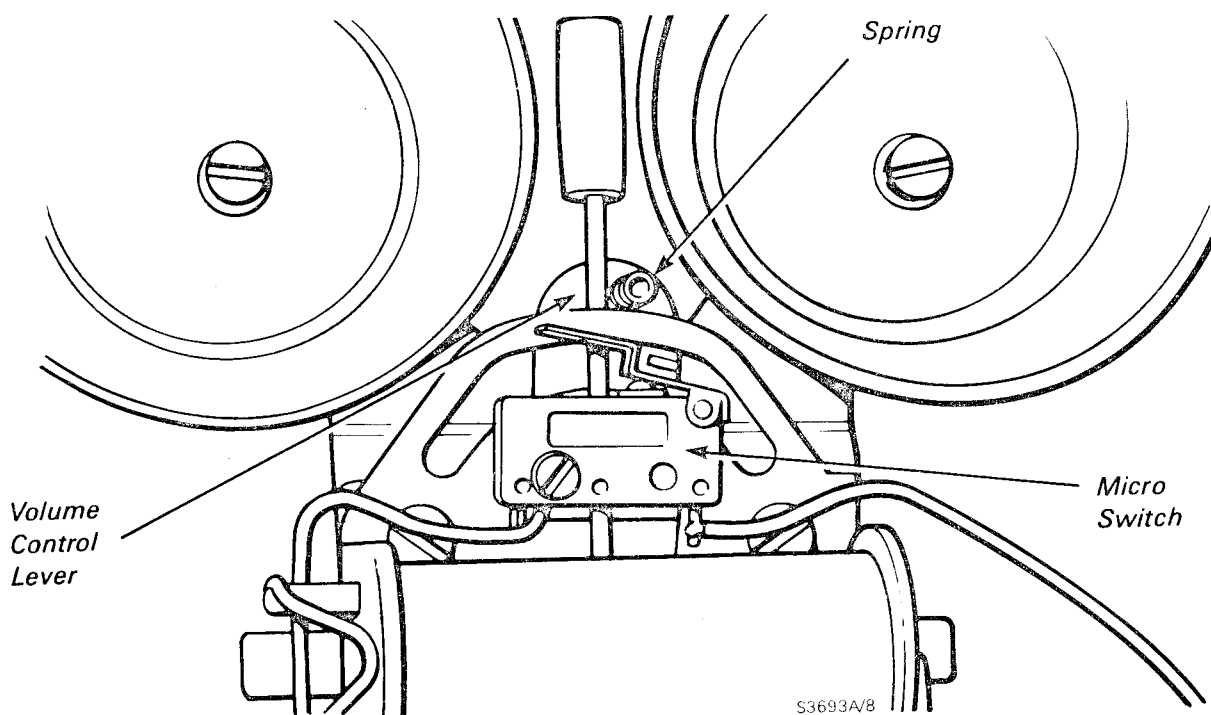

Fig. 26 Bell Unit 8001.

Handset 16 – Access to the microphone and receiver insets or other components is obtained by removing the fixing screw at the receiver end of the handset and **pulling** the two halves apart, starting at the receiver end. Do **NOT** use a screwdriver or other blade to prise the sections apart.

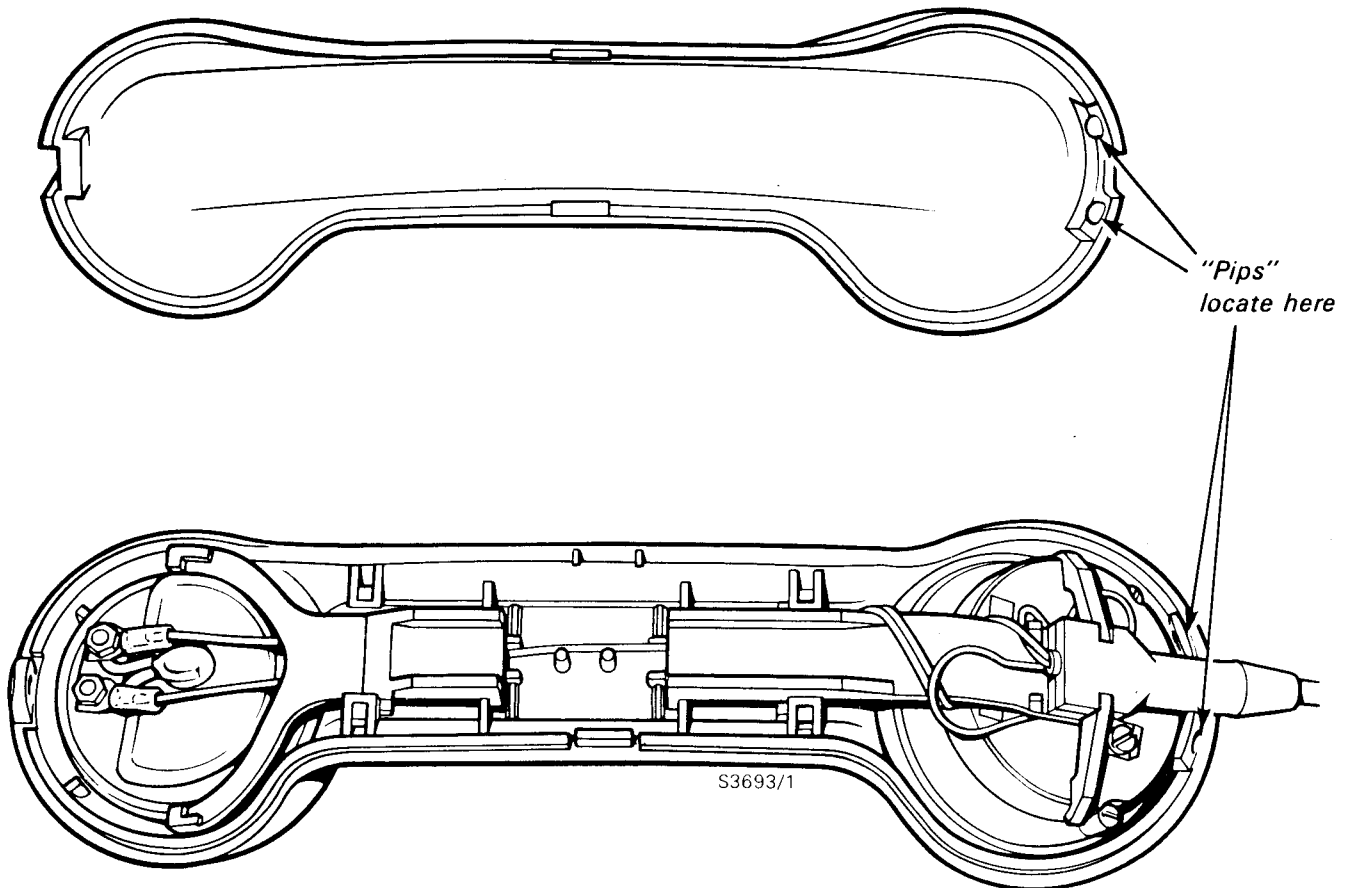
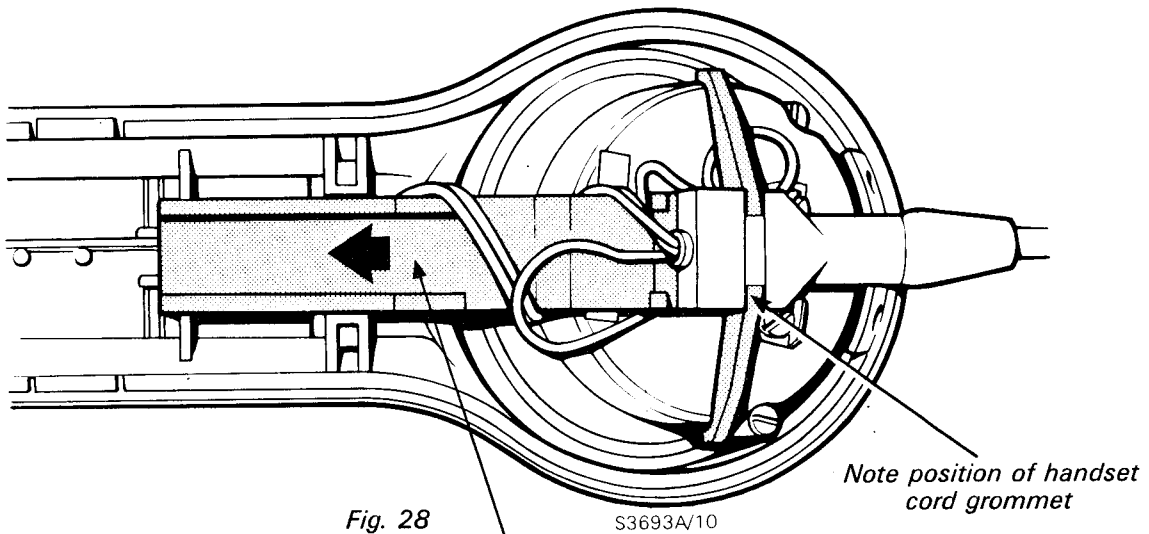

Fig. 27

The transmitter inset is a "linear microphone" type MICROPHONE INSET ...21A. "Carbon granule" type transmitter insets TRANS INSET 16 **must not be used** in Ambassador or 700 type telephones used together with Ambassadors on an installation.

Microphone and Receiver insets – may be removed by lifting the square cut end of the retaining clips and sliding each clip towards the centre of the handset as in figs 28 and 29. Before removing an inset, note how the leads are arranged to lie in the central groove. When replacing insets, make sure that the leads are not trapped and that the clips are correctly positioned.

The cord grommet must lie in the position shown in fig. 23, that is with the waist of the grommet located in the projections of the transmitter retaining clip.



To remove insets press down here and slide clip towards centre of handset.

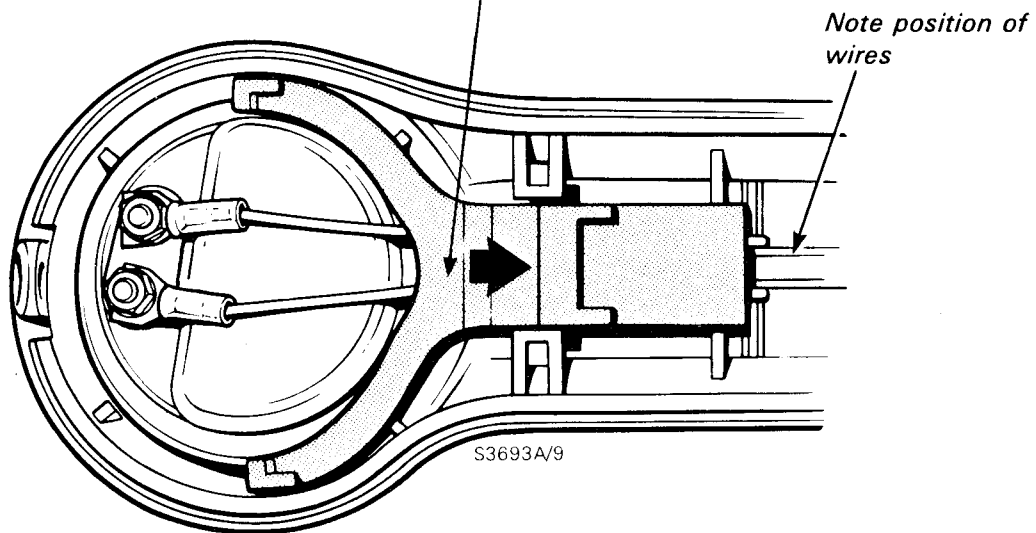

JACKS

There must be only one master jack per installation, to which the line is connected. The master jack (Jack No 620A or 621A or Line Jack Unit .../1A) contains a miniature gas discharge tube (SP1), this is a voltage surge protection element connected across the A & B lines to protect the telephone equipment against transverse high voltage surges.

LIGHTNING PROTECTION

Where a local earth is connected to the telephone equipment and the district is known to have a high incidence of lightning strikes a separate lightning protector should be fitted. This protector is connected between the A line and earth, and the B line and earth to protect against longitudinal surges.

7. Diagrams

General – The diagrams in this section include some symbols which may be unfamiliar, and components labelled in what may be unfamiliar terms.

Symbols

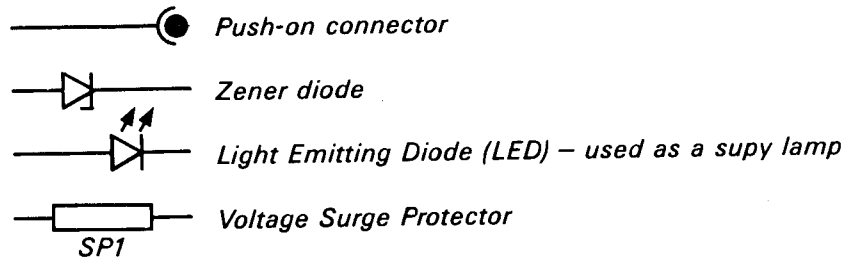

Terms

Anti-tinkle wire:– a wire run through an installation to provide a low resistance across all bells in the circuit when any one tele is in use.

Opt-out-of-service resistor:– this resistor in series with a $1.8\mu\text{f}$ capacitor provides a test condition to the line when the bell(s) is disconnected or the tele(s) unplugged.

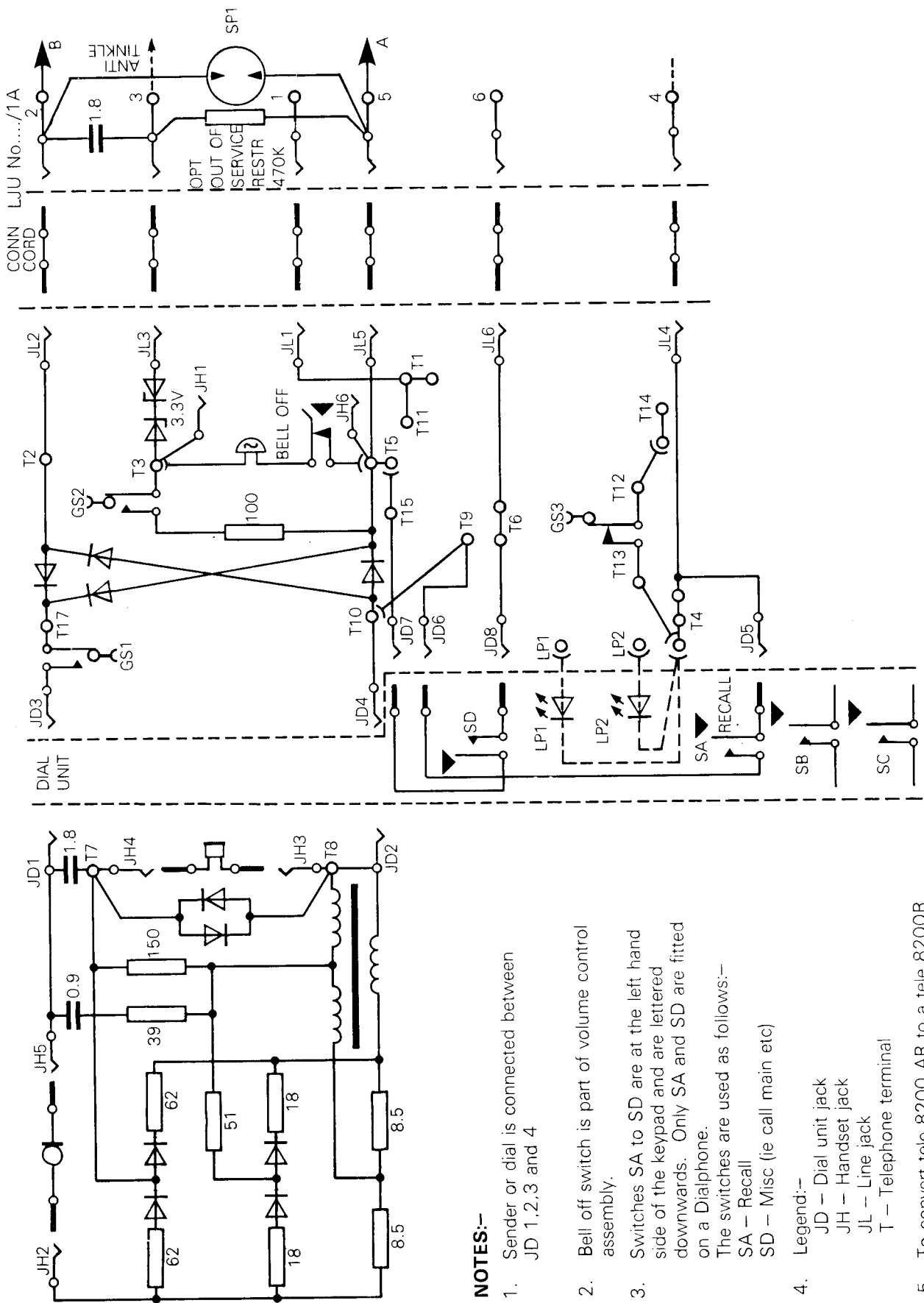

NOTES:-

1. Sender or dial is connected between JD 1,2,3 and 4
2. Bell off switch is part of volume control assembly.
3. Switches SA to SD are at the left hand side of the keypad and are lettered downwards. Only SA and SD are fitted on a Dialphone.
The switches are used as follows:-
SA - Recall
SD - Misc (ie call main etc)
4. Legend:-
JD - Dial unit jack
JH - Handset jack
JL - Line jack
T - Telephone terminal
5. To convert tele 8200 AR to a tele 8200R move keypad link from PLA-PLB connect link PLA-PLC. Some teles may be marked SKA-SKB, SKA-SKC

Fig 30 Telephone 8000 Type-"Basic" Telephone Circuit Diagram including Link Jack

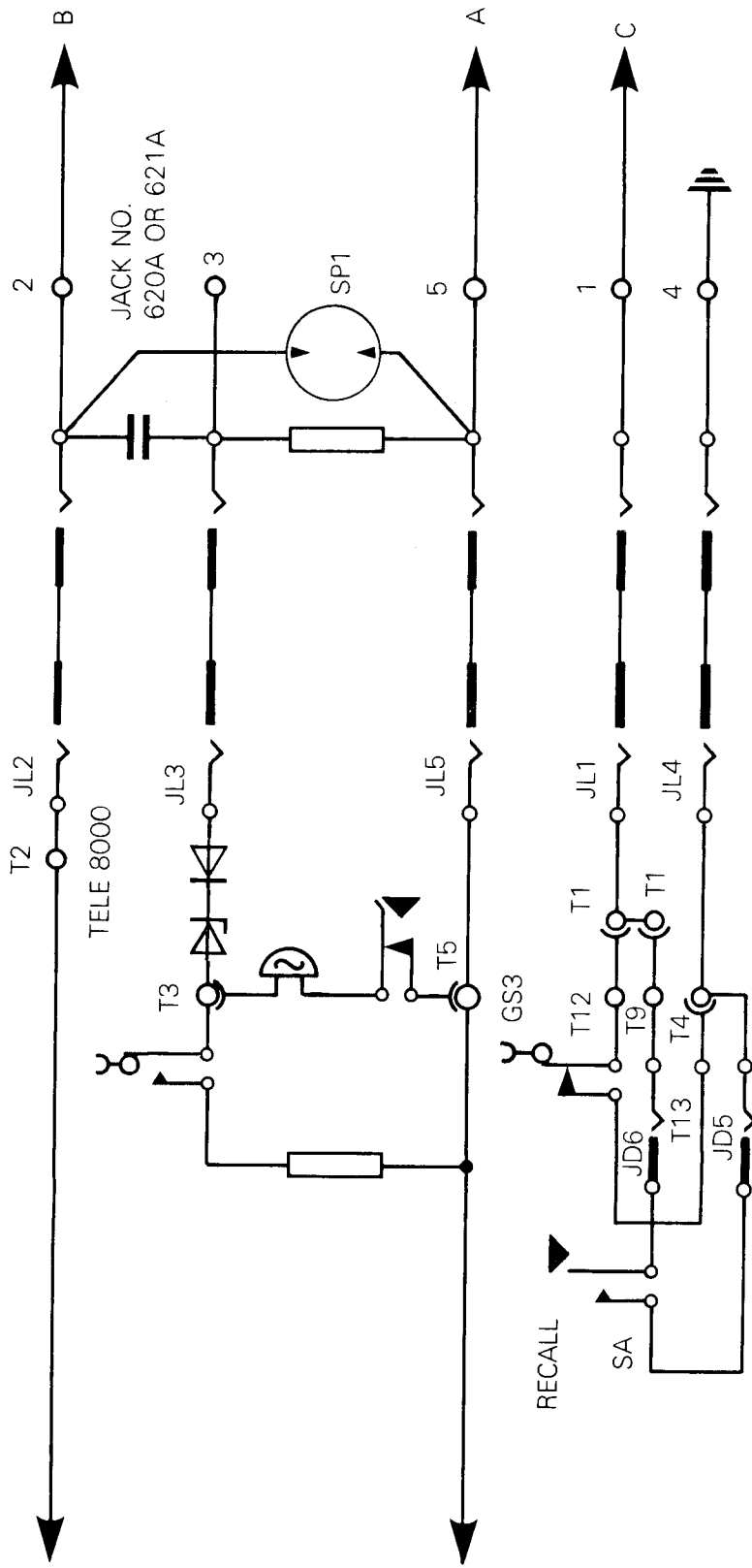

NOTES:-

1. Fit one LJU No.../1A
2. Connect earth to jack terminal 4.
3. Connect C wire to jack terminal 1.
4. Change line cord to 6 way.
5. Move a) T9 wire from T10 to T6 b) T12 wire from T14 to T6
6. Only one telephone per line may be fitted.

*Fig. 31 Tele 8000 Type – "Basic" Telephone PBX
Extn – C Wire Signalling*

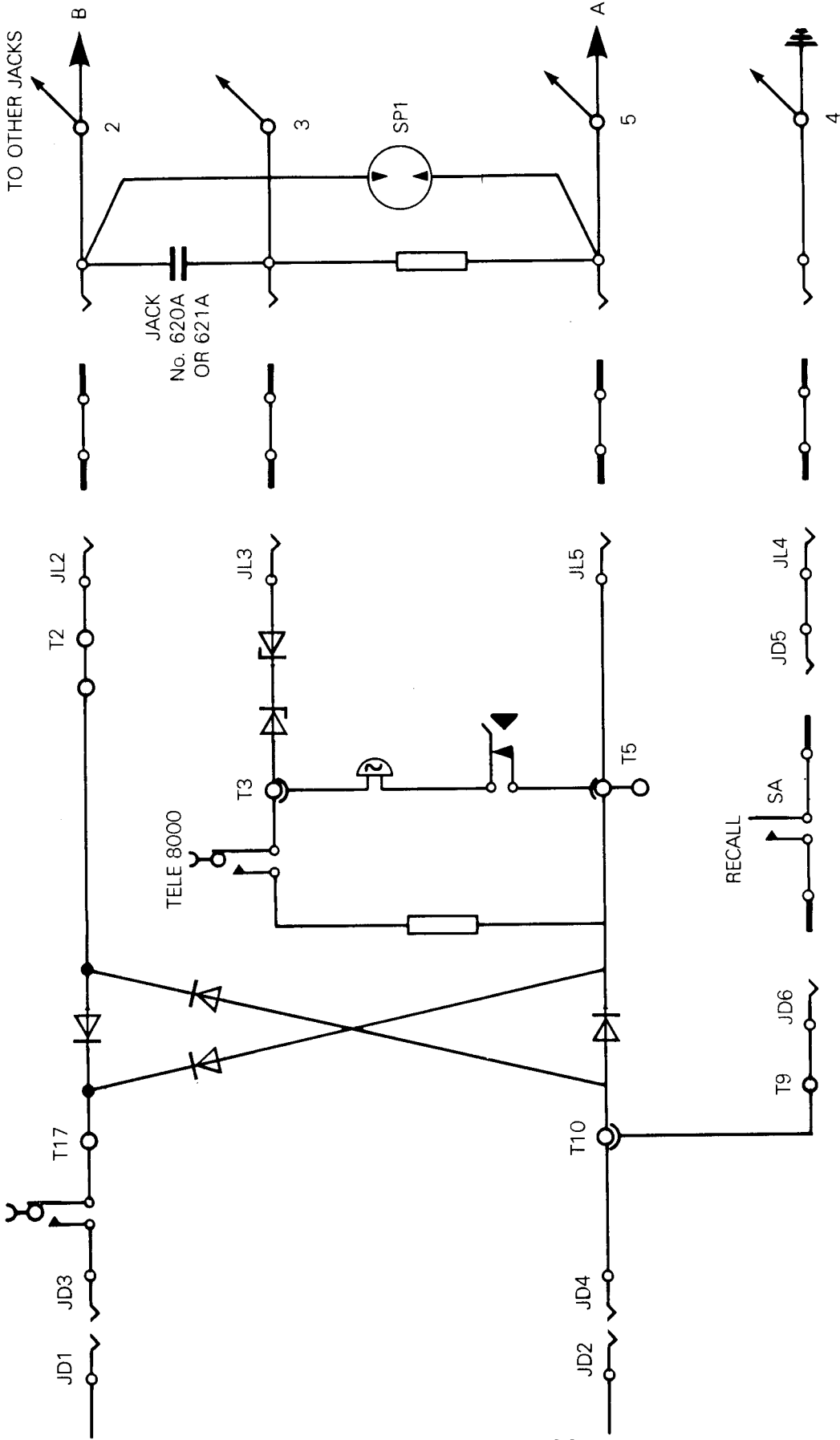

- NOTES:-**
1. Fit one LJU No..../1A and secondary LJU's as required
 2. Connect earth to jack terminal 4
 3. Plug in telephones 8000 as issued

Fig. 32 Telephone 8000 Type "Basic" Telephone PBX Extension - Earth Recall

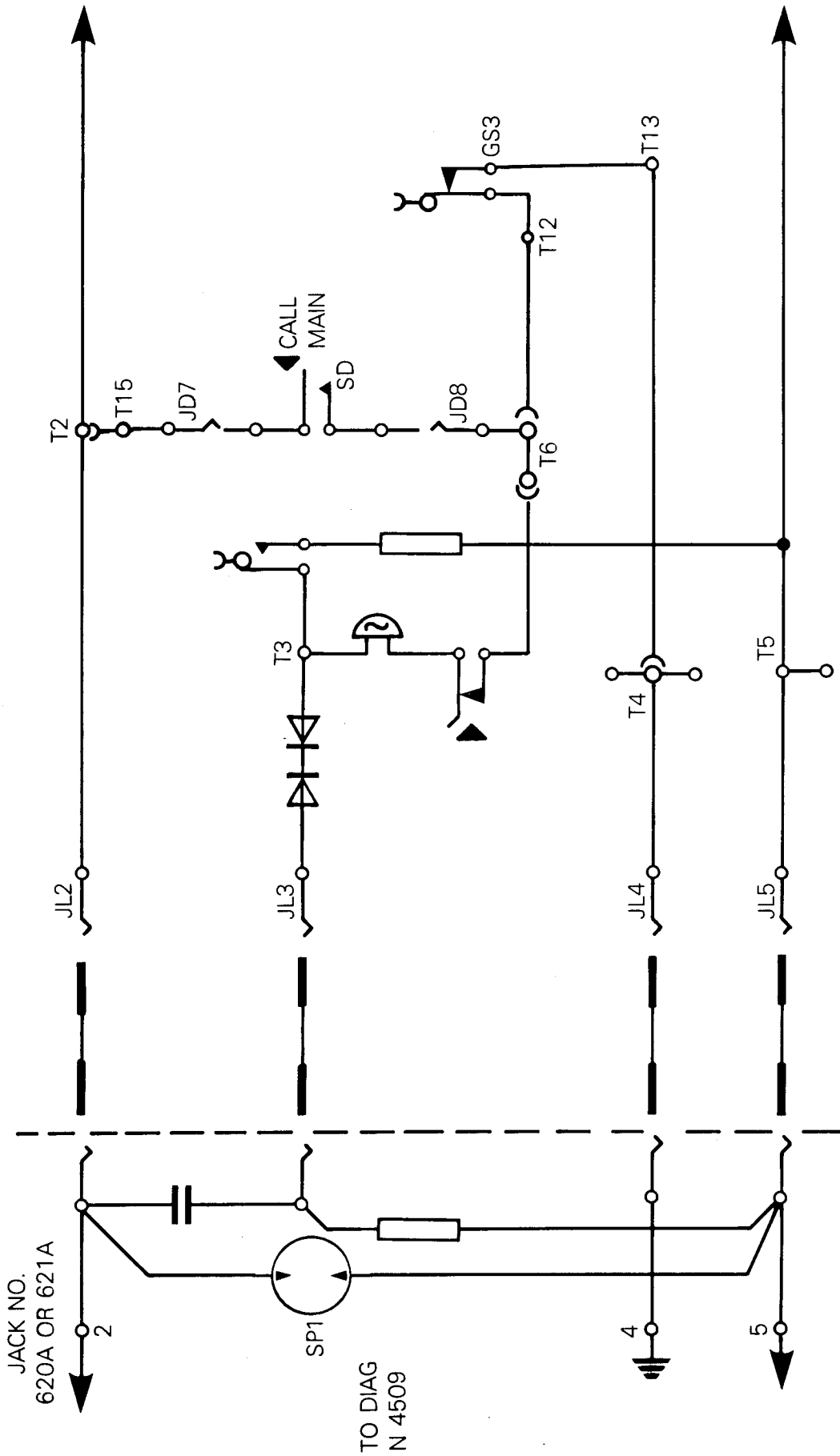

NOTES 1. Move:- (a) T15 wire from T5 to T2. (b) Bell "Off" wire from T5 to T6. (c) T12 wire from T14 to T6.

2. Connect earth to jack terminal 4.

3. Fit one LJU No.../1A

4. The telephone must be 'on hook' whilst 'call main' button is depressed.

Fig. 33 Tele 8000 Type - "Basic" Telephone 'B' end of Plan 107 External

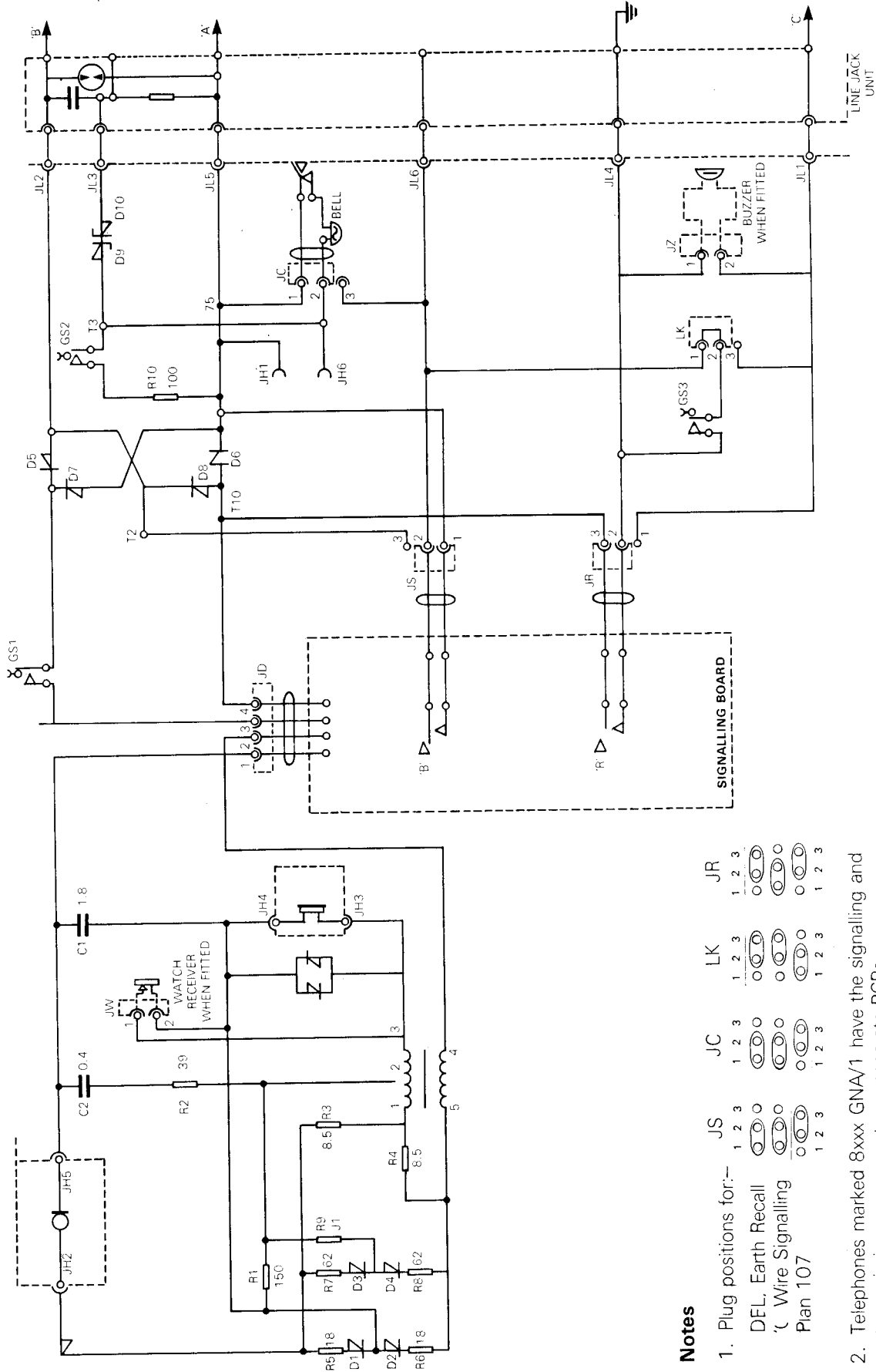

Fig. 34 Ambassador Telephone Developed (8xxx2 GNA.../1) TMC Version

Notes

- Plug positions for:-

JS	JC	LK	JR
1 2 3	1 2 3	1 2 3	1 2 3
DFL, Earth Recall			
'C' Wire Signalling			
Plan 107			
	1 2 3	1 2 3	1 2 3

- Telephones marked 8xxx GNA/1 have the signalling and transmission components on separate PCBs.
- The diagram shows telephone with plugs in position for D.E.L. or PBX extn with earth recall.

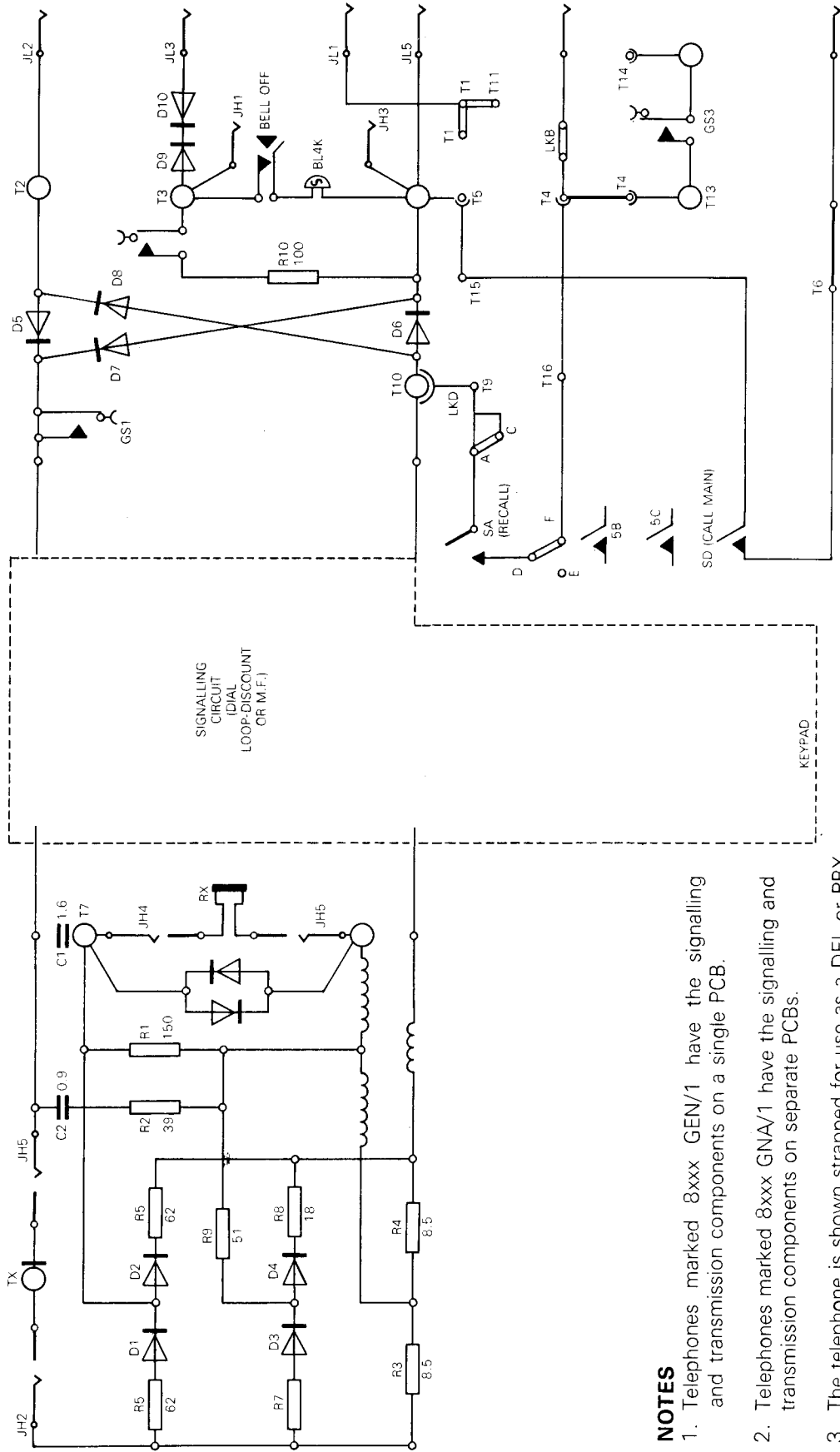

NOTES

1. Telephones marked 8xxx GEN/1 have the signalling and transmission components on a single PCB.
2. Telephones marked 8xxx GNA/1 have the signalling and transmission components on separate PCBs.
3. The telephone is shown strapped for use as a DEL or PBX extn with earth recall.
4. Terminals T17, T18, T19 are provided but are only used, in conjunction with JE, when the PCB is used in an Ambassador "Plan" telephone.

Fig. 35 Ambassador Telephone – Developed (8xx2 GEN.../1) GEC Version

8. Converted Bells & 8700 Type Tele

Table 1 High Impedance Bells and use in Existing Customer Apparatus

The following codes have been allocated for existing terms converted for use with N.G.T.:

1. BELL 59D-1 – High Impedance Version of Bell 59C-1 – Coils 2000 Ω d.c. resistance each. The coils will be protected with a distinctive colour covering.
2. TELEPHONE 8746C – Telephone 746 fitted with Bell 59D-1 and Mic Insert .21A and wired for use with NGT.
3. TELEPHONE 8741D – Telephone 741 fitted with Bell 59D-1 and Mic Insert .21A and wired for use with NGT.
4. BELL SET 26D – Bell Set 26 fitted with Bell 59D-1 and wired for use as N.G.T. Extn Bell
5. BELL SET 50C – Bell Set 50A fitted with Bell 59D-1 and wired for use as NGT Extn Bell
6. BELL SET 50D – Bell Set 50B fitted with Bell 59D-1 and wired for use with tele 713 when used in conjunction with NGT.
7. BELL 79D – High Impedance Version of Bell 79A-2 – Coil 4000 Ω d.c. resistance.
8. BELL UNIT 776D – Bell Unit 776 fitted with Bell 79D and wired for use with telephone 776-1 when used in conjunction with NGT.

9. List of Spare Parts

TABLE 2

The following list of parts are available as maintenance spares.

<i>Description</i>	<i>Vocabulary Title</i>
Basic Telephone – Dial version	Tele 8100*
Basic Telephone – Push Button, Self Contained.	Tele 8200*
Basic Telephone – M.F.	Tele 8300*
“Developed” Telephone – S.C.	Tele 8202*
“Developed” Telephone – M.F.	Tele 8302*
10 Address Repertory Dialling Telephone. (S.C.)	Tele 8220*
	* Denotes suffix letter
	R – earth recall
	RR – timed break recall
Line Cord 3000mm (Plug 431A at each end of cord)	Cord Conn 4/500(L. Grey) 3000mm
Line Cord 500 (Plug 431A at each end of cord)	Cord Conn 4/500(L. Grey) 500mm
Line Cord 150 mm (Plug 431A at each end of cord)	Cprd Cpmm 4/500(L. Grey) 150mm
Line Cord 420mm (Helical, Plug 431A at each end of cord)	Cord Conn 4/501(L. Grey) 420 mm
Line Cord 3000mm (Plug 431A at one end of cord, spade connexions at the other)	Cord Conn 4/502(L. Grey) 3000mm
Handset Cord 200mm (Helical, Plug 431A at one end of cord, space connexions at the other)	Cord Conn 4/503(L. Grey) 200mm
Line Cord 3000mm (6 conductors, Plug 431A at each end of cord)	Cord Conn 6/500(L. Grey) 3000mm
	Bracket Telephone 20
Handset	Handset No 16 a, b, c, d, e.
Transmitter	Microphone Inset ...21A
Receiver	Receiver 4T.
Battery for Tele 8220 GEC.	Battery Dry No 102
Battery for Tele 8220 TMC.	Battery Secondary No 33