

NOT TO BE SHOWN OUTSIDE BRITISH TELECOM

SENATOR 1 Call Connect System

THIS GUIDE NOTE IS
ISSUE 2 AND REPLACES
SENATOR ISSUE 1
DATED OCTOBER 1982.
ALL COPIES OF THAT
ISSUE SHOULD BE
DESTROYED.



SENATOR 1 — Call Connect System

These guide notes have been designed to assist Field Staff with the installation and maintenance of SENATOR systems. Both Installation and Maintenance staff will gain maximum benefit by reading every section.

Further copies of these guide notes can be obtained from the local Regional Distribution Centre.

Contents	Page
1. General Description	1
2. Installation	2
2.1. The Central Control Unit.	2
2.2. Cabling.	8
2.3. Exchange Line and Extension Wiring.	10
3. The Telephone	12
4. Commissioning Procedures	19
5. Facilities and Operating Procedures	20
6. Power Fail Arrangements	26
7. Maintenance	
8. How it Works	33
9. Parts List	34
10. Auxiliary Equipment	35
10.1 Extension Bells	35



1. GENERAL DESCRIPTION

The SENATOR Call Connect System (C.C.S.) is a microprocessor controlled switching system which can have up to five exchange or PBX lines and up to 10 extensions connected to it. (5 + 10).

It uses Ambassador style telephones, Tele 85xx (see Fig. 1), with plug and socket connections to all cordage. The telephones are connected by 4 wires to a Central Control Unit (CCU) which houses the system power unit, the main elements of the control circuits and terminations for the lines.

The CCU has a power consumption of 150 watts and the customer must provide a suitable three pin mains outlet for it.

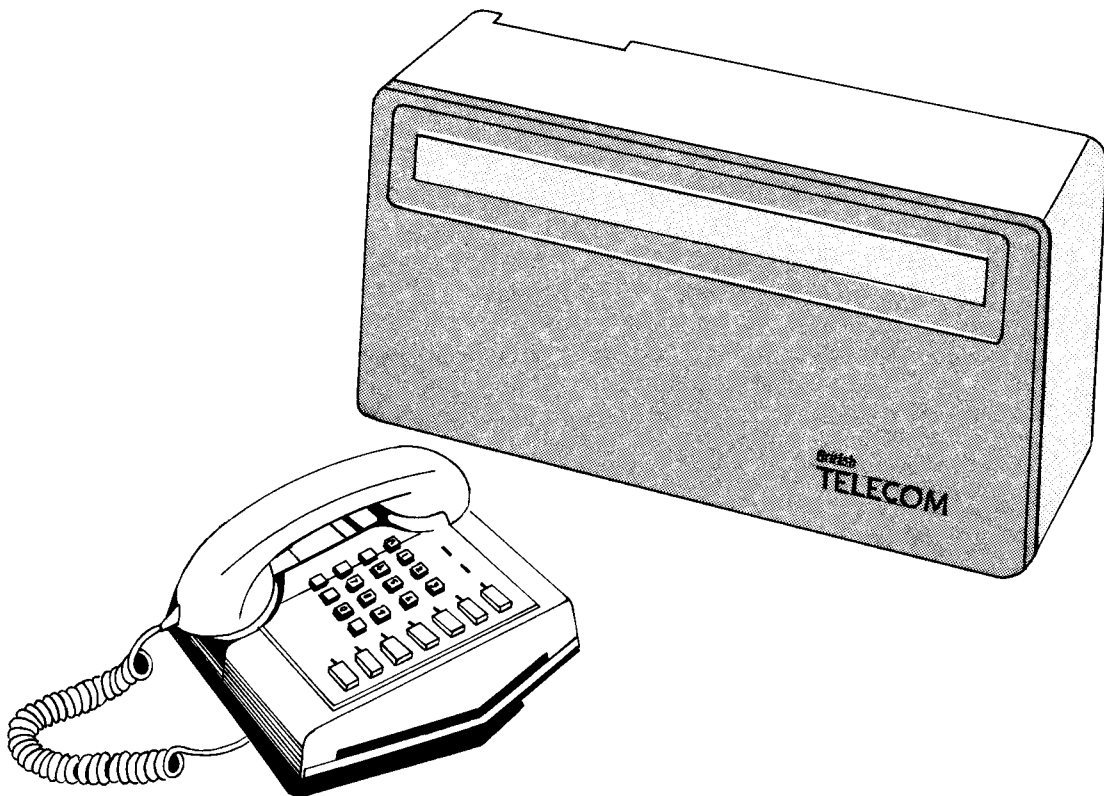

Fig. 1 SENATOR telephone and Central Control Unit.

SENATOR is available for LOOP/DISCONNECT or MF4 signalling systems and can be used on any of the following lines:-

- DEL's — exclusive only
- PBX extensions — with or without earth loop recall
- Private circuits

SENATOR can **NOT** be used on P.B.X. extensions which use 'C' wire or timed break recall.

2.

INSTALLATION

2.1. THE CENTRAL CONTROL UNIT

The CCU is equipped as follows:-

- i. CCU Housing Assembly, comprising:-
 - a) Rear Mounting Assembly,
 - b) Case,
 - c) Front Cover
 - ii. One microprocessor board (Backplane)
 - iii. One Line Termination board
 - iv. One Power Supply Unit
 - v. One 5-Exchange line ASU
 - vi. Three 2-Extension Line ASUs.
- These items comprise a "SENATOR KIT NO 1C"

Early versions of Senator were 'Senator Kit 1A or 1B' and parts from these are fully interchangeable with a Senator Kit 1C, except for the Microprocessor boards (Backplanes). (See Section 7).

An Intercom Apparatus Slide-in Unit (ASU) (either Loop/Dis or MF, as required) must be requisitioned separately, as must any additional Extension Line ASUs that are required for the system.

The Rear Mounting Assembly, see Fig. 2, contains the "Backplane" which is the main printed circuit board (PCB) carrying the microprocessor circuitry, sockets for up to seven Lines /Intercom ASUs and a secondary PCB which carries the termination blocks for exchange line and extension cable terminations. The CCU **must never** be transported with the Power Supply Unit in position as this will strain the mounting lugs and so cause damage.

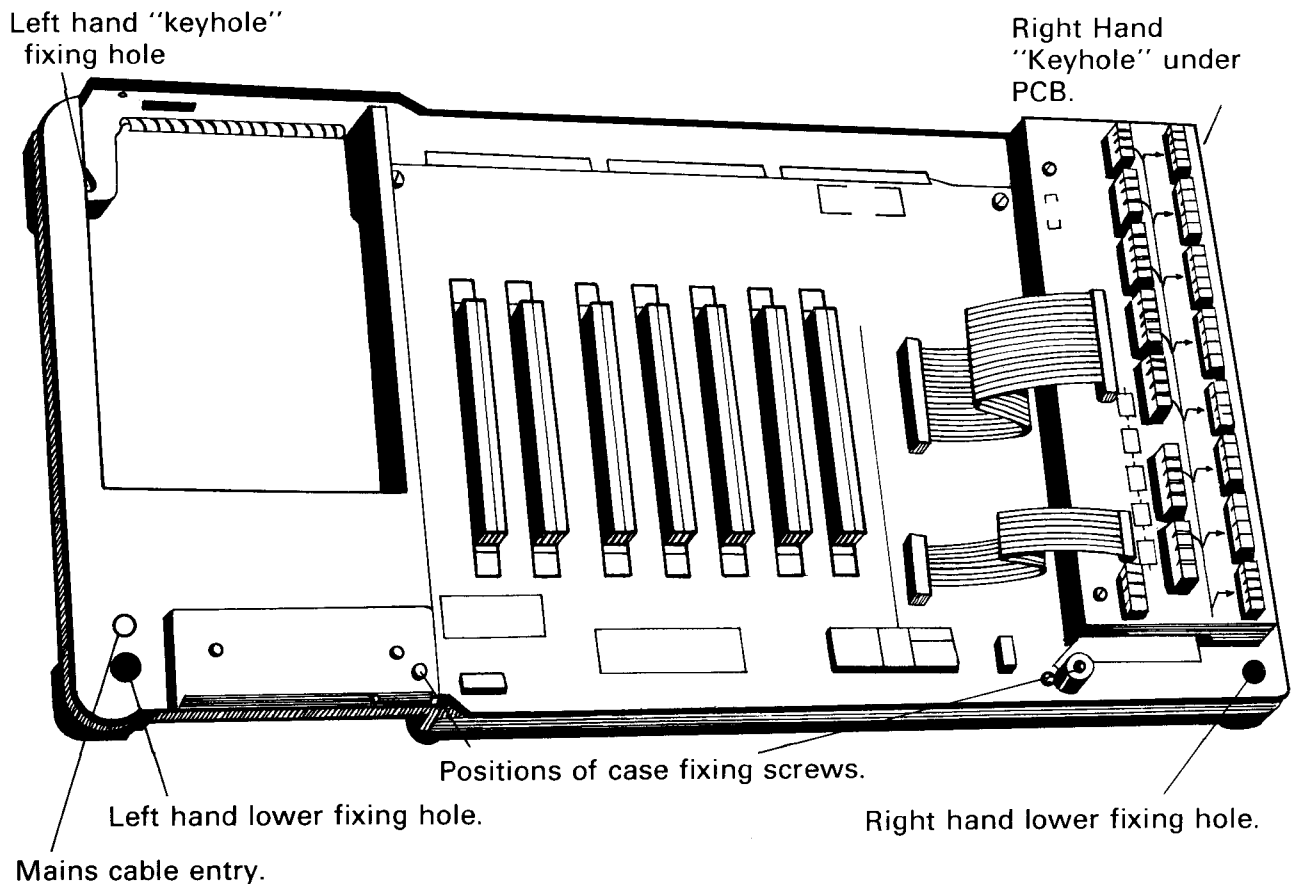

Fig. 2. Rear Mounting Assembly.

INSTALLING THE CCU

The CCU should be wall mounted on a suitable flat, sound surface. This should be within 3m of a mains socket outlet and should allow the CCU to be clear of the floor and any obstructions.

Preparation

First remove the front cover and the case from the rear mounting as follows:-

- i. Remove the fixing screws in the top left and right hand corners of the front cover.
- ii. Ease the top of the front cover away from the case, lift the cover clear and disengage the lugs from the slots in the case.
- iii. With the cover removed, remove the two screws holding the case to the rear mounting, see Fig. 2.
- iv. Ease the lower edge of the case away from the rear mounting, lift the case clear and disengage the lugs from the slots at the top of the rear mounting.

Fitting the rear mounting assembly

- i. Drill and plug two holes, suitable for No. 10 woodscrews, at a suitable height above the floor or any obstruction. The two holes must be 495mm apart horizontally.
- ii. Fit, but do not fully tighten, No. 10 woodscrews into these plugged holes.
- iii. Offer the rear mounting assembly to the wall so that the two screws enter the "keyholes" in the top corners of the assembly. Slide the mounting so that the screws are in the slotted portion of the "keyhole".
- iv. Check that the mounting assembly is horizontal and adjust if necessary. Mark the wall through the lower fixing holes.
- v. Remove the rear mounting assembly from the wall, drill and plug the lower fixing holes for No. 10 woodscrews.
- vi. Feed the free end of the mains cable through the entry hole in the rear mounting assembly from the rear, see Fig. 2. Leave about 220mm of cable free at the front of the mounting assembly.
- vii. Refit the rear mounting assembly to the wall and tighten all fixing screws.

FITTING THE POWER SUPPLY UNIT (PSU)

- i. Remove the two countersunk screws fitted in the top surface of the PSU. Keep these screws handy, ready to fix the PSU in place.
- ii. With the voltage selector towards the front, fit the tab on the rear of the PSU into the slot at the left-hand side of the rear mounting assembly.
- iii. Pivot the PSU on the tab to swing into the rear mounting assembly.
- iv. Align the screw holes in the top surface of the PSU with holes in the rear mounting assembly.
- v. Replace and tighten the two countersunk screws, through the holes in the rear mounting to secure the PSU.

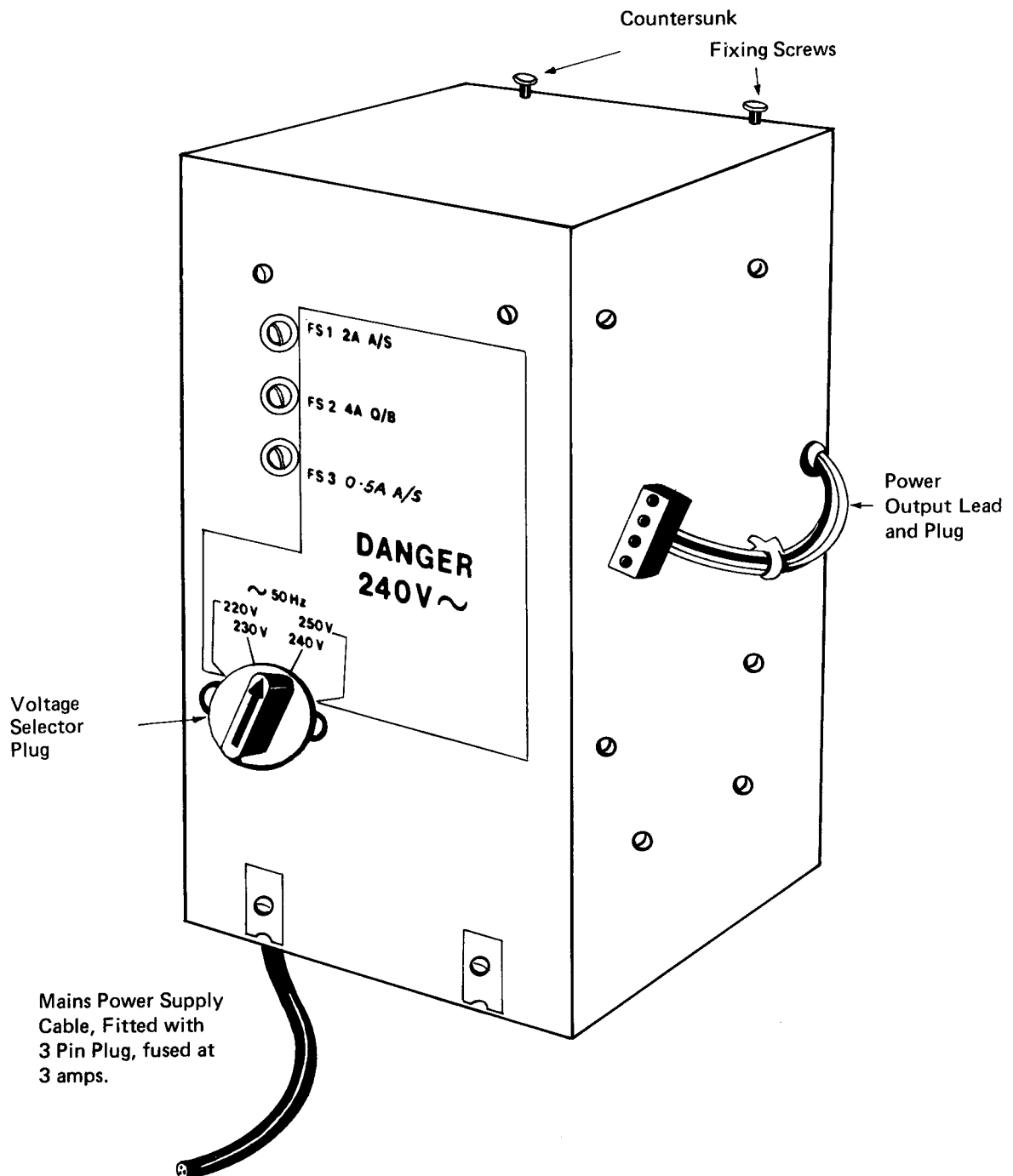

Fig. 3. Power Supply Unit (PSU).

- vi. Connect the mains cable to the PSU. A mains cable, not more than 3m long must be obtained locally, and terminated to the terminal block which with its associated cable clamp is mounted in the bottom of the PSU, see Fig. 4.
 - a) Remove the self-tapping screws which hold the cable clamp to the terminal block. Turn the clamp through 90°.
 - b) Fit the mains cable into the clamp allowing sufficient cable to project to allow for terminating.
- vii. Terminate the mains cable to a 13 amp 3 pin plug, fused at 3 amps, following the standard colour code:-
 - Brown to "L" or LIVE
 - Blue to "N" or Neutral
 - Green-Yellow to "E" or Earth. (\perp).

Do not plug in at this stage.
- viii. Insert the power unit output plug into the socket provided on the "Backplane". The plug is polarised and can only be inserted one way.
- ix. Set the voltage selector to the correct input voltage which will normally be 240 V. The voltage selector is NOT A SWITCH but a plug. It should be unplugged, turned to the required voltage setting and then pushed home.

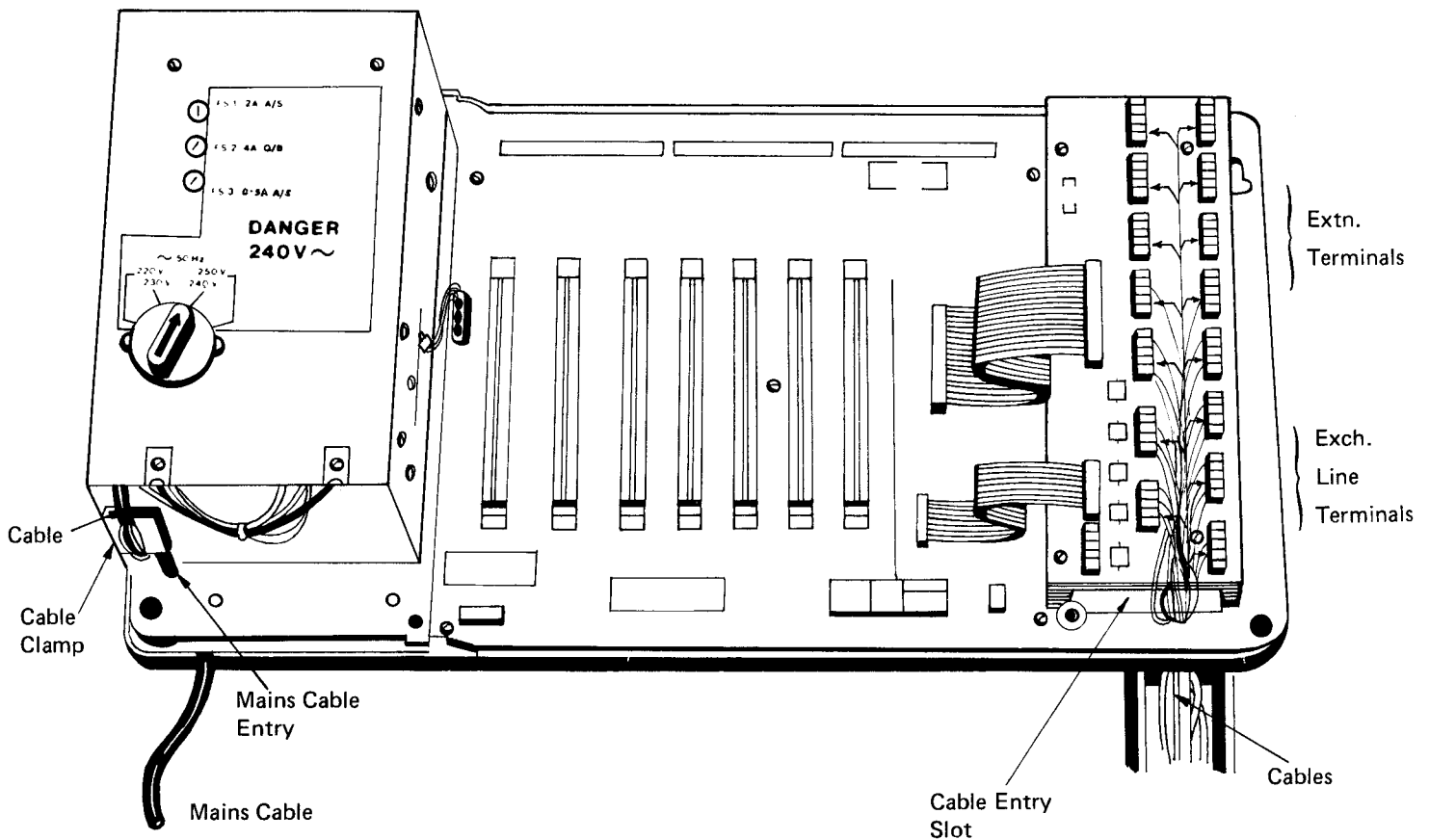

Fig. 4. PSU in position on Rear Mounting Assembly.

FITTING THE APPARATUS SLIDE-IN UNITS.

If it is more convenient, the exchange line and extension cables may be terminated on the C.C.U. before the rest of the C.C.U. is assembled. (See Sections 2.2 and 2.3).

Refit the Case

The case should now be refitted to the rear mounting.

- i. Engage the lugs in the upper rear of the case with the slots in the rear mounting.
- ii. Swing the case into position.
- iii. Fit and tighten the case fixing screws.
- iv. Fit the plate carrying the spare fuses in their carriers to the two screws at the lower edge of the PSU. This plate covers the gap between the PSU and the case to prevent accidental contact with the mains connexions. (See Fig. 6).

Fitting the Apparatus Slide-in Units (ASU)

The Exchange Line ASU, the Intercom ASU and the Extension ASUs can now be fitted. Each is carefully slid into its respective guide as in Fig. 5. Ensure that the card is positioned correctly before fully pushing it into its socket. The positions for the ASUs are shown in Fig. 6.

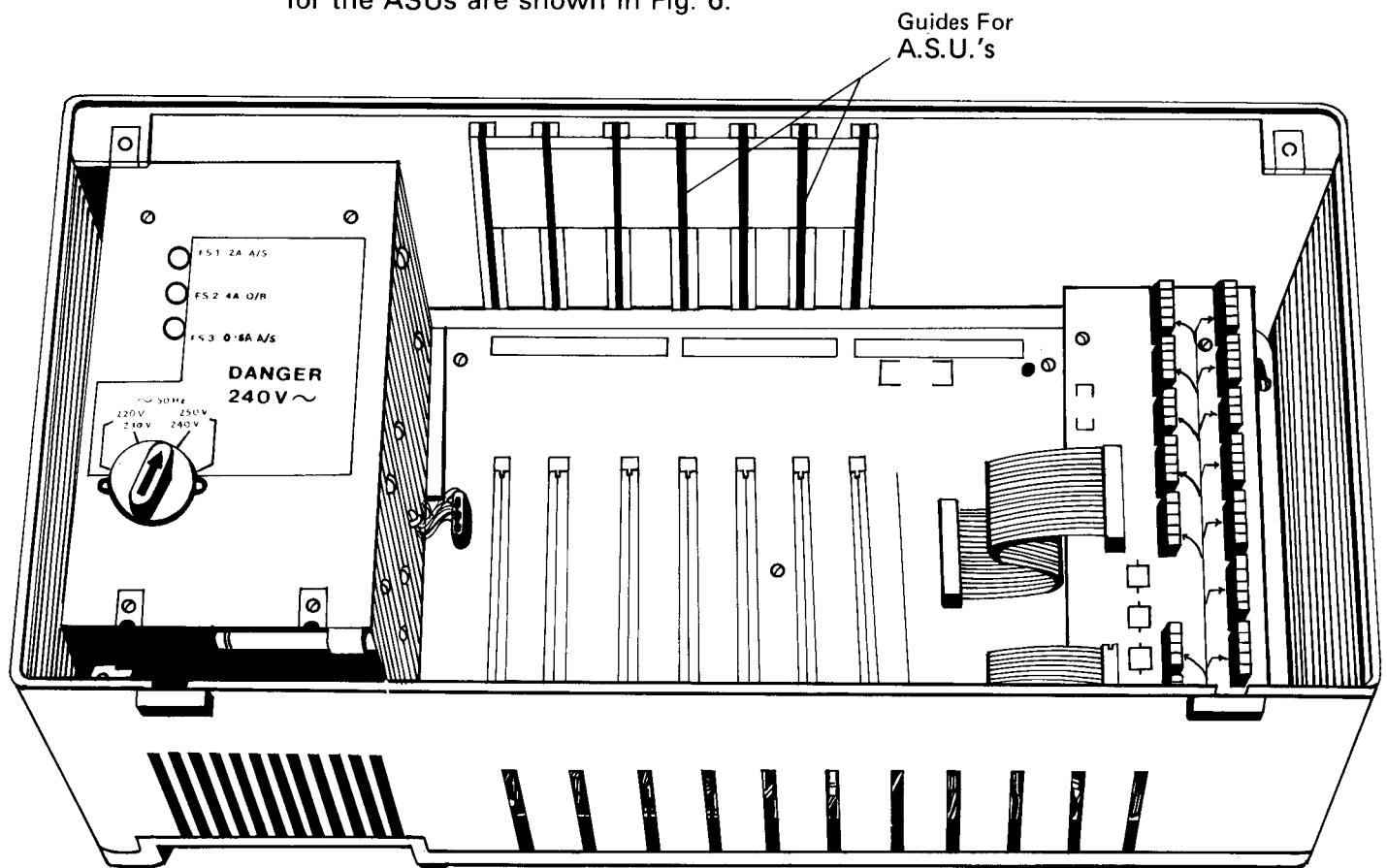
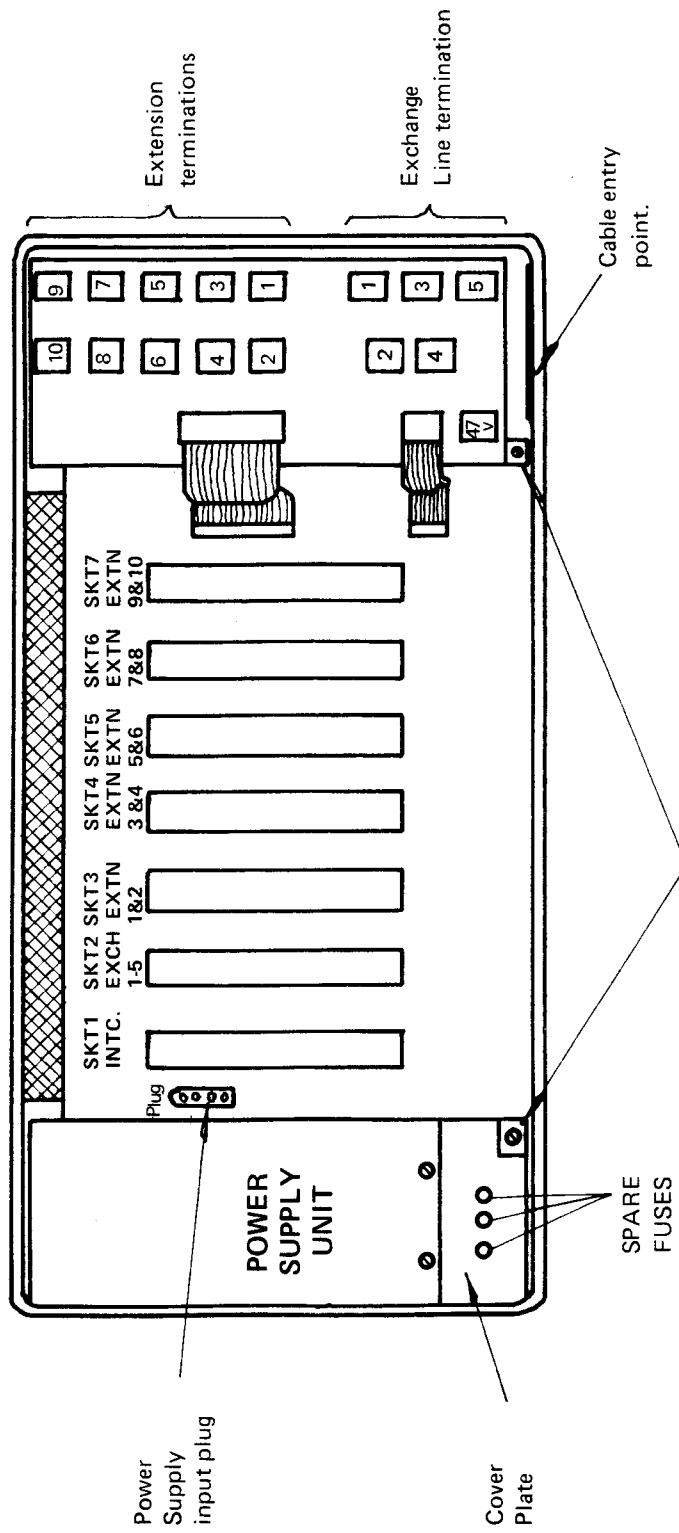

Fig. 5. C.C.U. With Case in Position.



Case retaining screws

- SKT 1 INTERCOM ASU (DPA 1210 /A [LOOP /DIS] OR DPA 1217 /A [MF4])
- SKT 2 EXCHANGE LINE ASU (DPA 1207 /A [5 LINES])
- SKT 3 EXTENSIONS 1 — 2 ASU (DPA 1209 /A)
- SKT 4 EXTENSIONS 3 — 4 ASU (DPA 1209 /A)
- SKT 5 EXTENSIONS 5 — 6 ASU (DPA 1209 /A)
- SKT 6 EXTENSIONS 7 — 8 ASU (DPA 1209 /A)
- SKT 7 EXTENSIONS 9 — 10 ASU (DPA 1209 /A)

Fig. 6 CCU Layout

CABLING

SENATOR uses 4 wires between the telephone sockets (LJU No. .../3A) and the CCU. The 4 wires comprise 2 speech wires and 2 data wires.

It has been found that quad formation 4 wire cables cause overheating between the speech and data pairs so although two wires are spare, 6 wire Cable Equipment 2503F must be used because it is of twisted pair formation, and therefore free of the overheating problem.

A maximum loop resistance of 250Ω is permitted between an extension and the CCU. Using 0.5mm conductors this is the equivalent of a route length of 1.5Km of cable.

Where an earth is required for PBX recall, a bunched 0.5mm cable pair should be run from the local signalling earth to the CCU. The mains protective earth should not be used for this purpose.

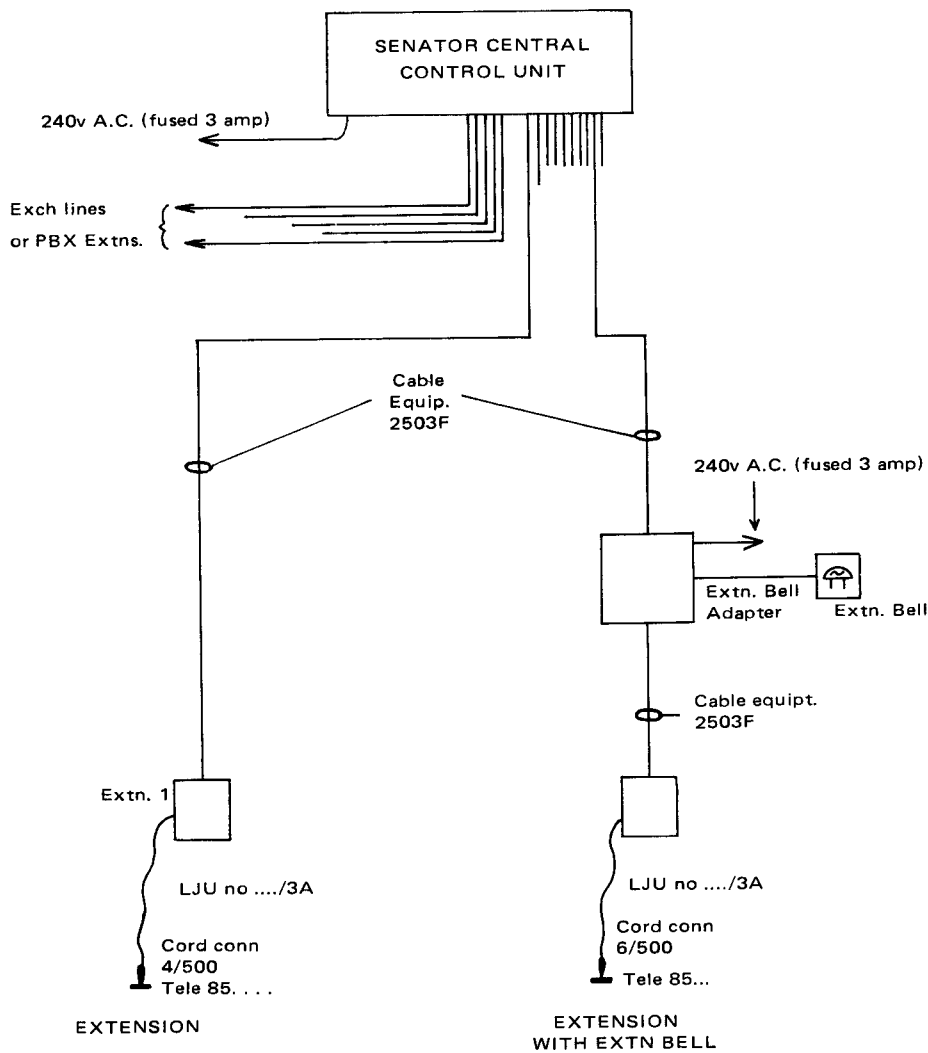
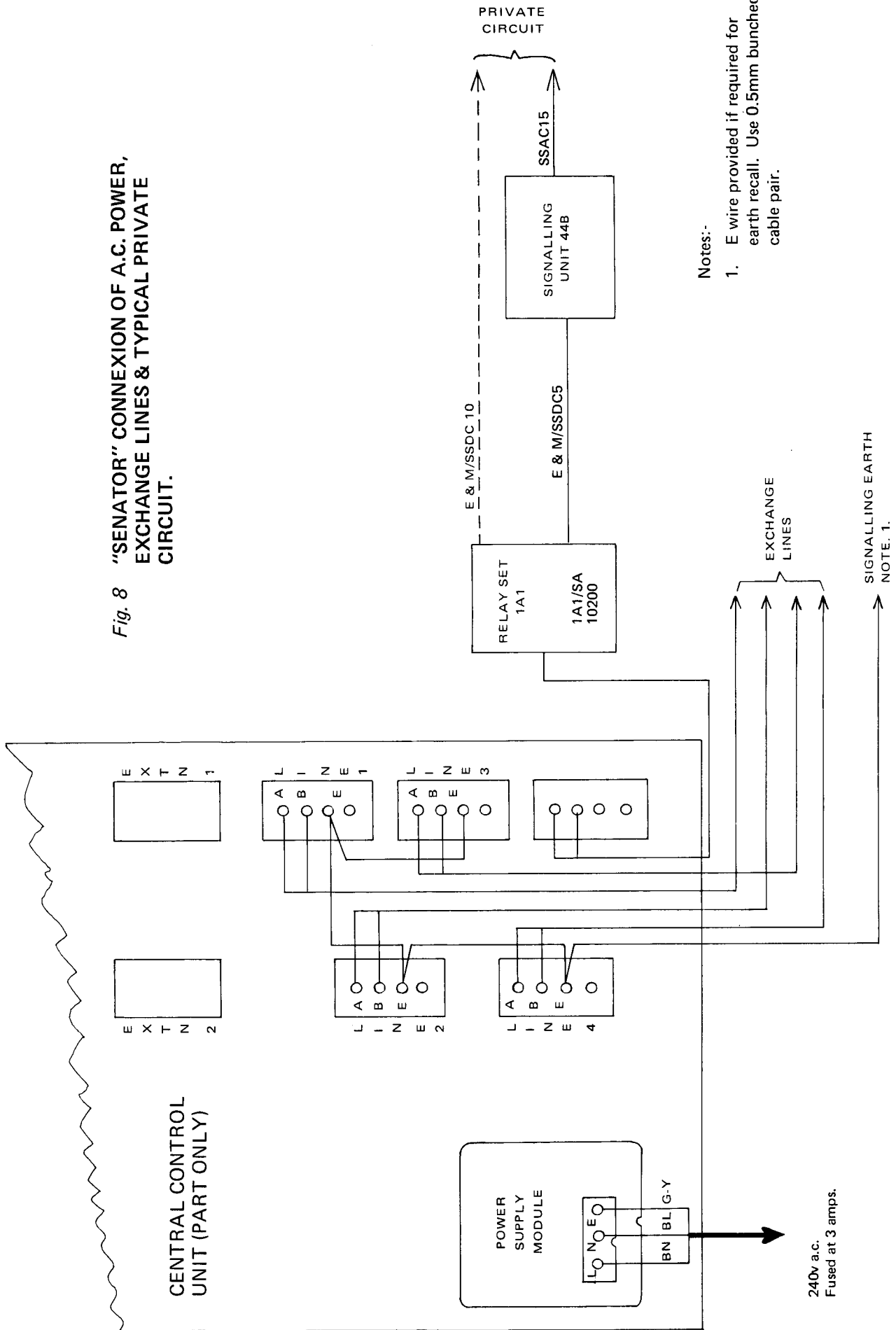

Fig. 7. Typical layout and cabling for SENATOR.

Fig. 8 "SENATOR" CONNEXION OF A.C. POWER, EXCHANGE LINES & TYPICAL PRIVATE CIRCUIT.



Notes:-

1. E wire provided if required for earth recall. Use 0.5mm bunched cable pair.

240v a.c.
Fused at 3 amps.

SIGNALLING EARTH
NOTE. 1.

2.3. EXCHANGE LINE AND EXTENSION WIRING

The cables bringing exchange lines and extension connections to the CCU should be fed under the rear mounting plate to enter the CCU through the slot in the bottom right-hand corner, see Fig. 6. All extensions **must** use "twisted pair" type cable, Cable Equipment 2503F (6 wire). All cables are terminated on insulation displacement connexions using an Inserter Wire 2A.

Terminate the exchange lines and extensions on the appropriate connector block. These are labelled on the PCB.

Note that exchange line blocks have 3 terminals, these being A & B wires and Earth (for use when required for PBX working). Extension blocks have 4 terminals, A & B being the speech pair, C & D the data pair. The data pair and speech pair must not be transposed nor must the data pair be reversed wire for wire.

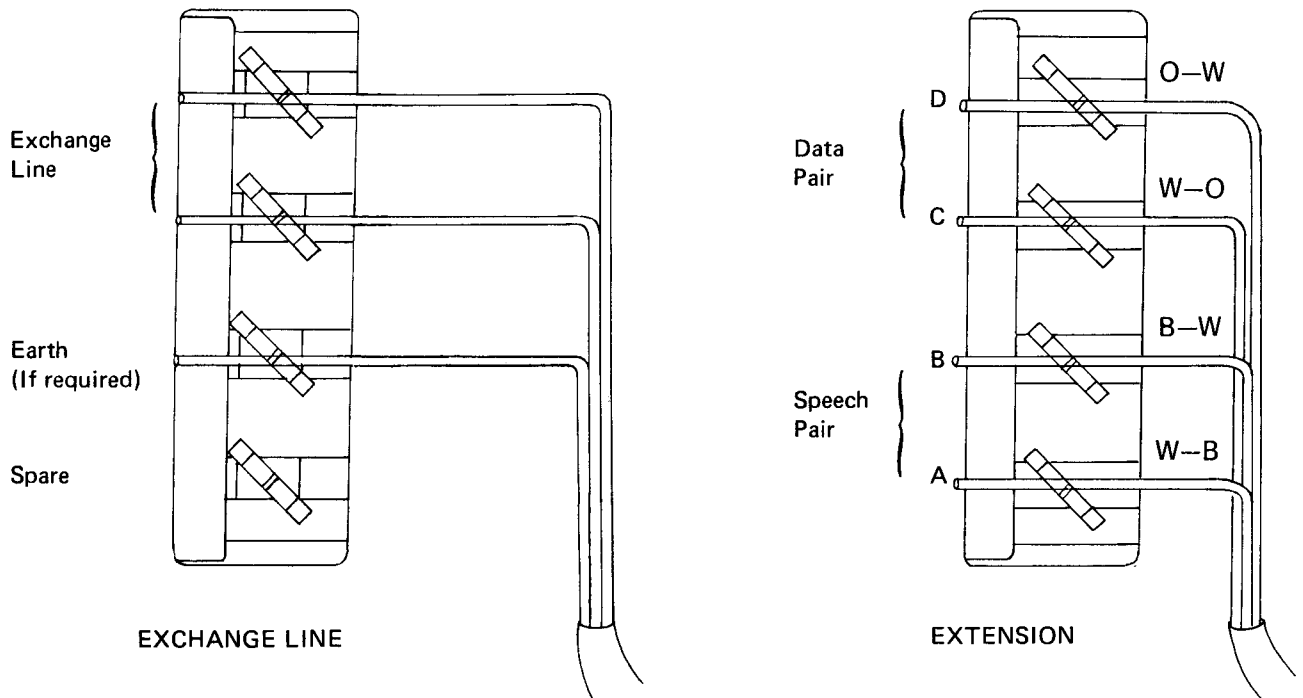
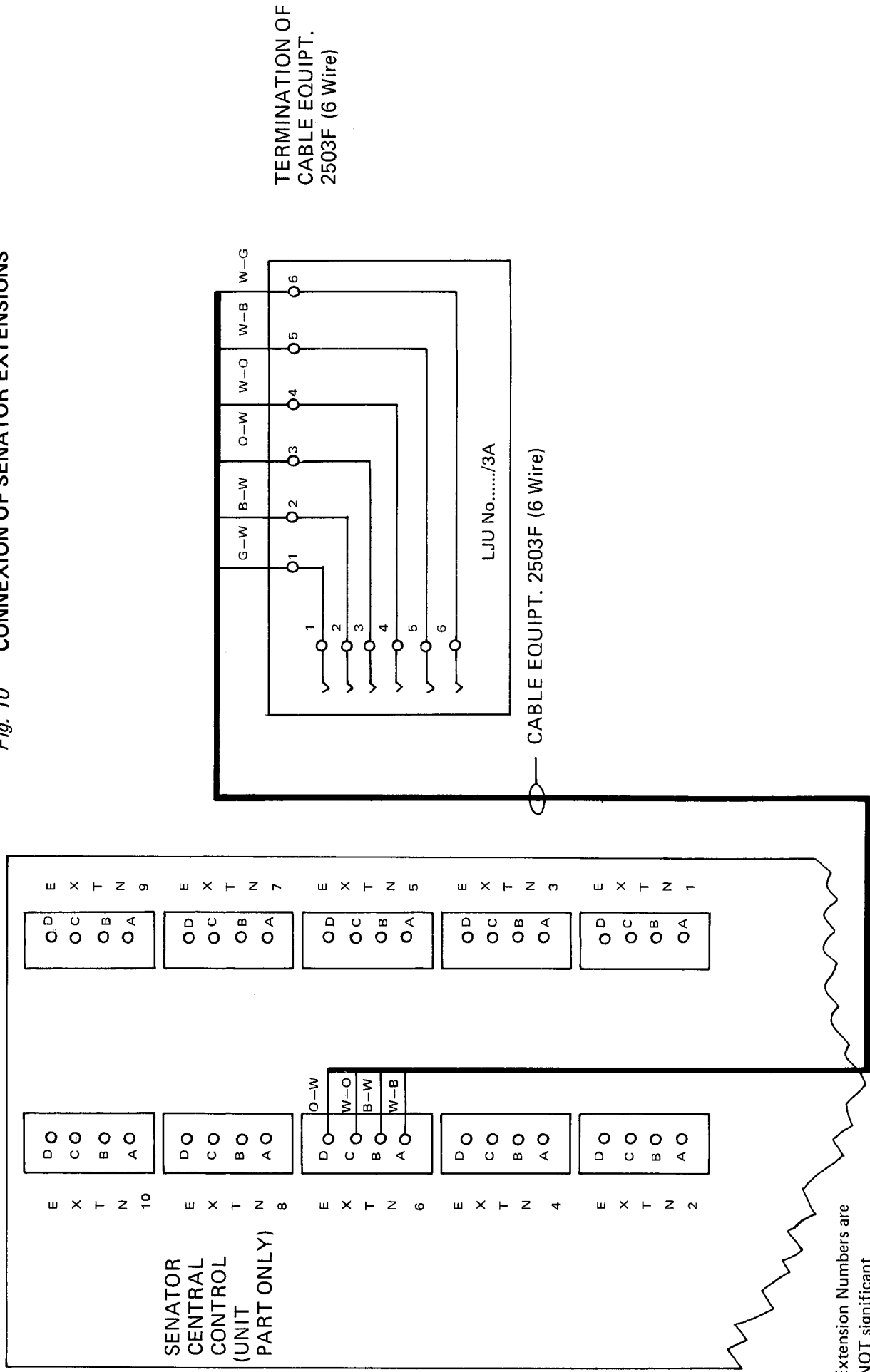

Fig. 9. Termination of Exchange Line and Extension Cables.

The cables at each extension should be terminated onto an LJU No. .../3A. (See diagram opposite).

Fig. 10 CONNEXION OF SENATOR EXTENSIONS



NOTE: 1. Extension Numbers are NOT significant

3. THE TELEPHONE

The telephone has the same styling as the Ambassador telephone but has a wider body to accommodate an extra row of press buttons, each of which has an associated light emitting diode (LED). These buttons are used to obtain incoming and outgoing Exchange line access, and for the "DIVERT" and "HOLD" facilities. A green LED which is used with the Divert facility, and a yellow LED which is not used on the Senator System, are located above the keypad. Early versions of the telephone had the colours of the LED's by the Hold and Divert buttons reversed to those shown in Fig. 11.

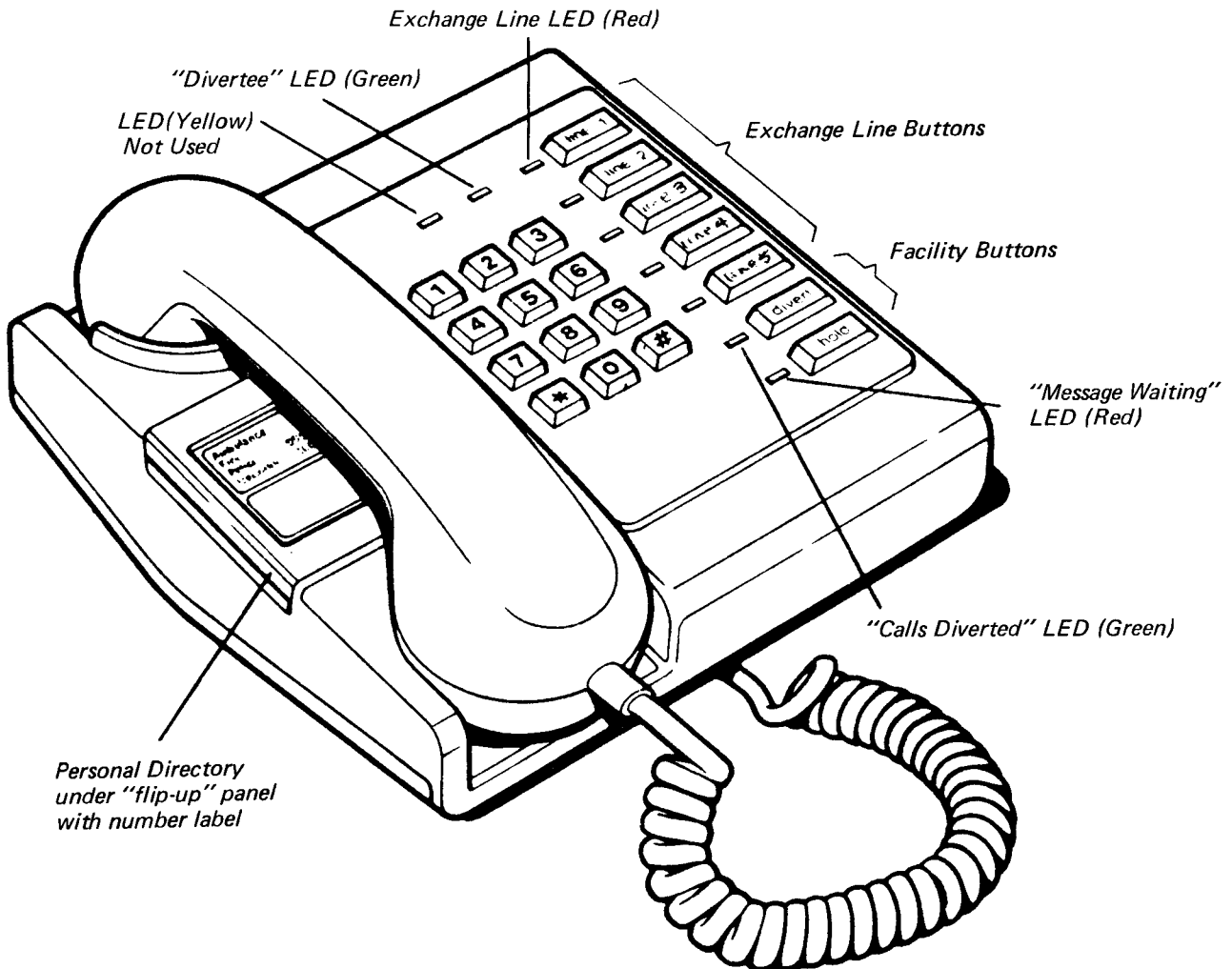

Fig. 11. Tele 8530

SENATOR telephones which are available in either brown or stone are:-

SENATOR Telephone 8520 (SC) - self-contained loop /disconnect

SENATOR Telephone 8530 (MF) - multi-frequency signalling

SENATOR Telephone 8521 (SC) - 10 address repertory dialling

Telephones 8521 require a Battery Dry No. 102

Button Designations

The exchange lines and facilities are allocated to the same buttons on every telephone as follows:-

BUTTON	ALL EXTNS.
1	LINE 1
2	LINE 2
3	LINE 3
4	LINE 4
5	LINE 5
6	DIVERT
7	HOLD

Installations which do not have all five exchange lines provided should have blank labels fitted in the spare buttons. They should not be "locked" because they may be required for use with the "Divert" facility.

Tone-Caller and Buzzer

The telephones contain a tone-caller and a buzzer, but normally only the buzzer operates on incoming calls, be they intercom or from an exchange line.

Normally the tone-caller in each telephone will only operate under power-fail conditions to indicate an incoming call on the exchange line connected to that particular telephone. The tone-caller may be arranged to operate at all times, however, by using an Extension Bell Adapter. (See Section 10.1).

Cords

Both the line cord and the handset cord are plug ended and plug into sockets contained under a lid which also covers a battery container.

The base of the telephone (Fig. 12) allows for the line cord to enter from either the rear or the left-hand side of the telephone.

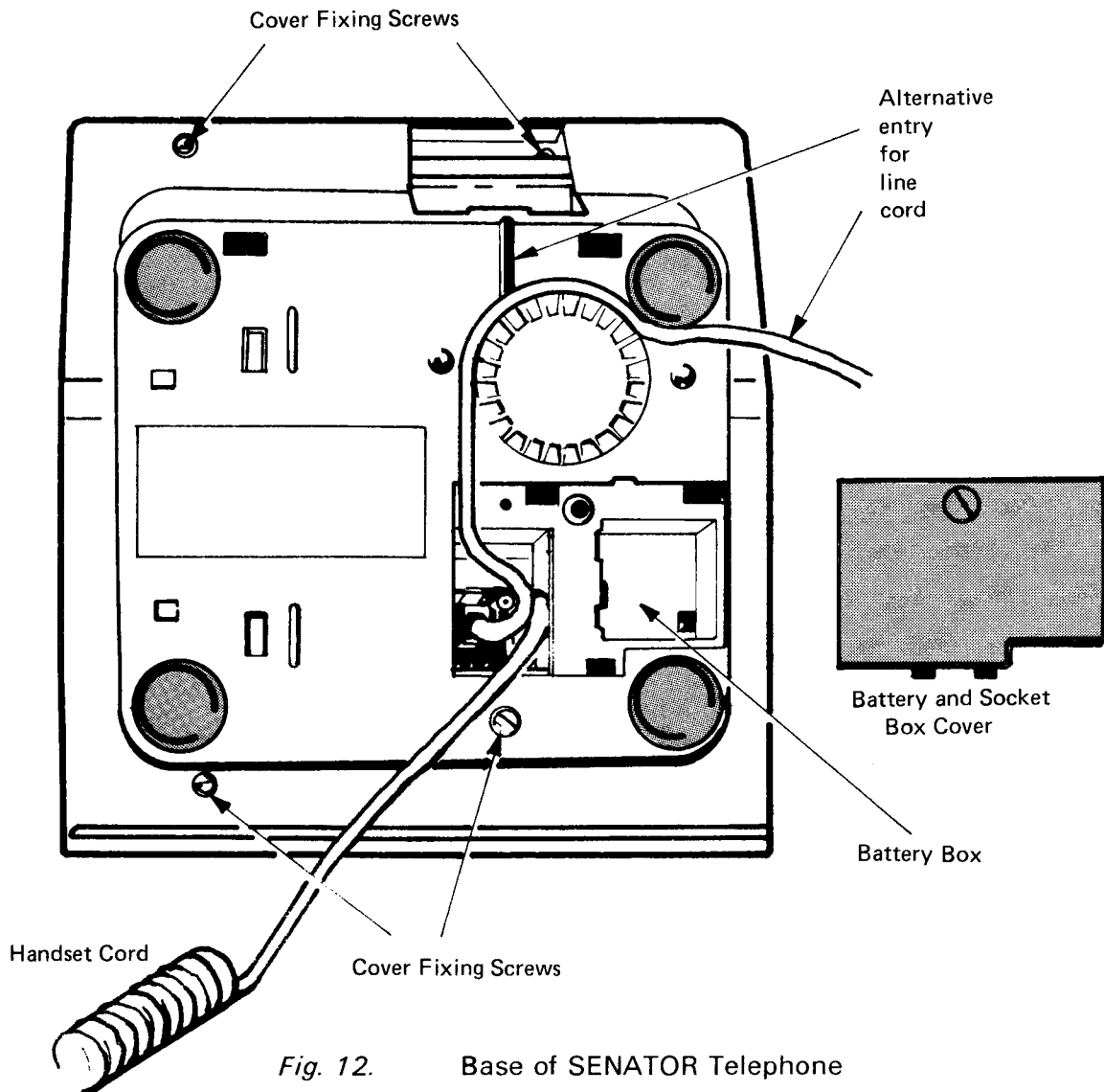

Fig. 12. Base of SENATOR Telephone

Handset No. 16

The telephone uses the Handset No. 16B which is distinguishable from the Handset 16A by its "Pepper Pot" earpiece and a small recess under the earpiece.

A number of facility handsets are also available, but at present only two of them may be fitted to Senator telephones.

- Handset 16C — amplified handset with volume control at rear of earpiece.
- Handset 16E — locking/non-locking on-off switch — used as a transmitter cut-off.

A small number of early installations of Senator were provided with Handsets 16D by using an Extension Bell Adapter.

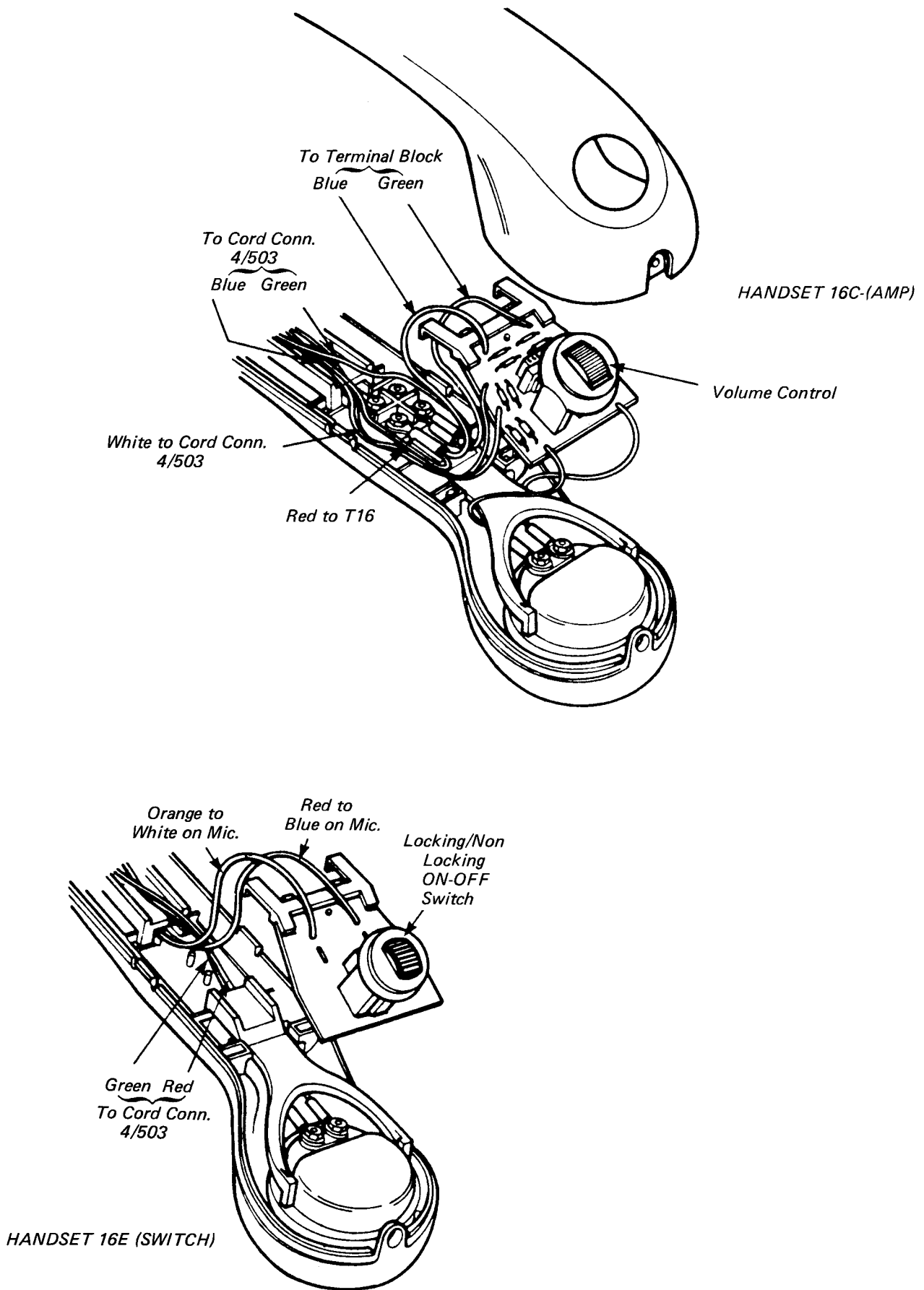

Fig. 13. Handsets Nos. 16C and E.

Access to the microphone and receiver insets or other components is obtained by removing the fixing screw at the receiver end of the handset and pulling the two halves apart, starting at the receiver end. Do **not** use a screwdriver or other blade to prise the sections apart.

To reassemble the handset, start at the transmitter end, engage the two "pips", one either side of the cord entry, into their associated holes in the other half. Squeeze the two sections together. Replace the fixing screw.

The transmitter inset is a "linear microphone" type, Microphone Inset No. 21A. "Carbon granule" type transmitter insets (Trans Inset No. 16) **should not normally be used** on SENATOR type telephones. Certain types of microphone Inset No. 21A can cause problems such as 'howling' or 'humming' when used on Senator telephones. Microphone Insets 21A RIA should be used when these problems are experienced.

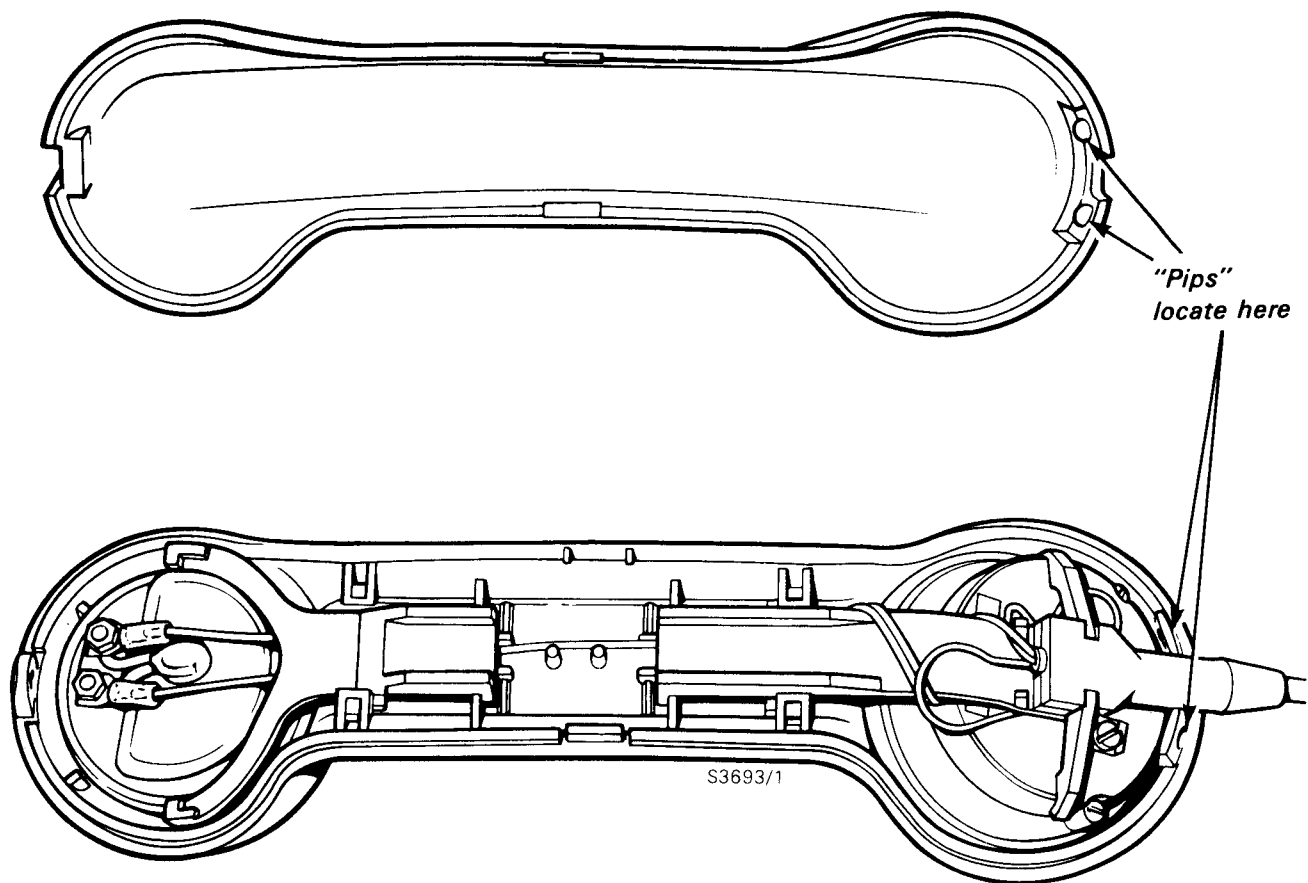

Fig. 14

Microphone and receiver insets are removed by pressing downwards on the centre of the retaining clips and sliding the clip towards the centre of the handset as in Fig. 15. Before removing an inset note how the leads are arranged to lie in the central groove. When replacing insets make sure that the leads are not trapped and that the clips are correctly positioned.

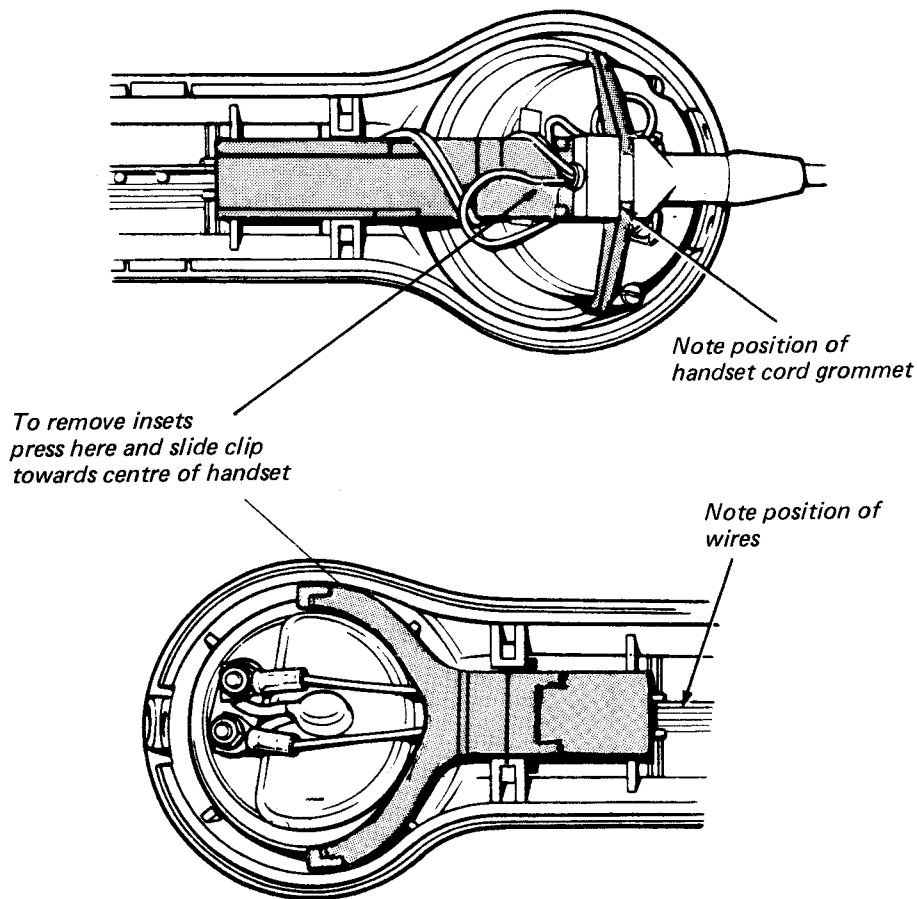
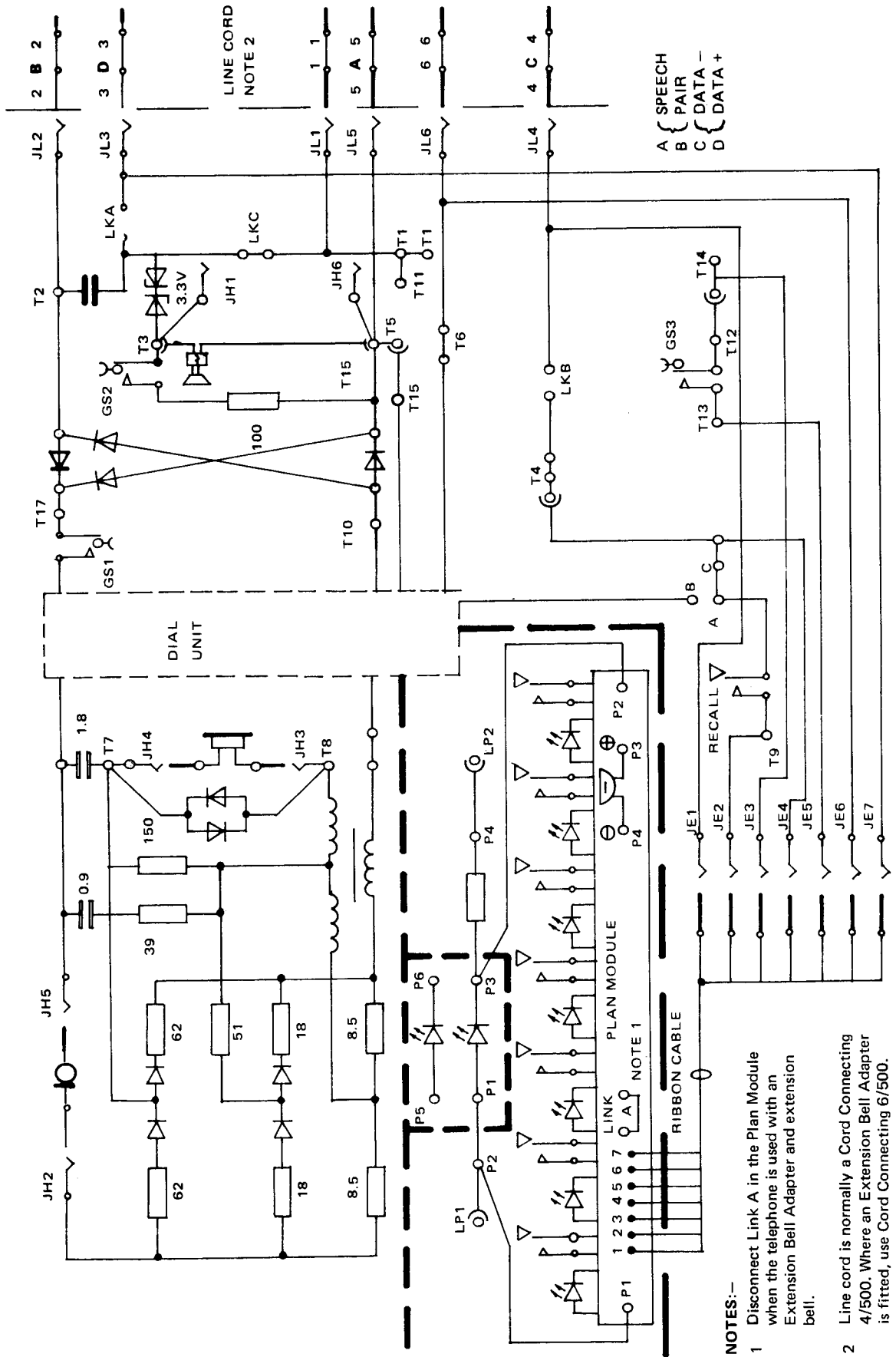

Fig. 15. Removal of Transmitter and Receiver.

The cord grommet must lie in the position shown in Fig. 15 that is with the waist of the grommet located in the projections of the transmitter retaining clip.

Fig. 16 TELEPHONE 8500 TYPE CIRCUIT



4. COMMISSIONING PROCEDURES

The system should not be commissioned until all the cables have been terminated in the CCU and at every extension.

Fit the lid to the CCU and connect the mains supply to the Unit.

The system is now running and ready for service.

Each extension should be tested as follows:-

- a) With the handset in place on the telephone.

Press and hold down the 'Hold' button.

All the red 'Exchange Line' LED's should light to indicate that the extension will be rung by incoming calls on every line.
The LED's will not light if the data pair is reversed.

- b) Pick up the handset and listen for system dial tone, a continuous two-tone sound.
- c) Test the keypad by keying the extension's own number and listening for engaged tone.
- d) Check the operation of the buzzer in the telephone by obtaining a ring back.
- e) Check exchange line access by obtaining dial tone (or the P.B.X. operator) on each working line.

5. FACILITIES AND OPERATING PROCEDURES

TONES

The system generates its own tones which are used on internal calls. These are:-

- i. Ring Tone (RT). This is a 440 Hz tone with a regular 0.262 secs ON, 0.262 secs OFF cadence.
- ii. Ringing. On internal calls the buzzers are operated to the same cadence as system ring tone. On incoming exchange calls the buzzers operate to exchange ringing cadence.
- iii. Engaged Tone (ET). This is a 440 Hz tone with a regular 0.131 secs ON, 0.131 secs OFF cadence.
- iv. Number Unobtainable (NU). This is a continuous 440 Hz tone.
- v. Dial Tone (DT). This is a continuous tone of 350 Hz + 440 Hz.
- vi. "Pip" or "Click" Tone. If all the extensions programmed to be rung by an incoming call on an exchange line are busy or in 'Divert' then "Pip" or "Click" Tone will be connected to the intercom circuits to indicate an incoming call. A single 'pip' of tone is repeated at approximately 5 second intervals.

EXCHANGE LINE SERVICE

An exchange line that is engaged will be indicated by the LED associated with the line button either:-

- i. Glowing steadily, indicating a call in progress.
- ii. Flashing at ringing cadence, indicating an incoming call.
- iii. Flashing at the "Hold" cadence to indicate a "Call Held" condition.

Outgoing Calls

An extension can make an exchange line call on any line which is free. On lifting the handset system dial tone will be heard. When the button associated with a free exchange line is depressed the caller is connected to the exchange line and the exchange dial tone is received. The required number can then be keyed in the normal manner.

Incoming Calls

An incoming exchange call is signalled by the relevant exchange line LED flashing to exchange ringing cadence at each extension. Also, the buzzer at any extension that is programmed to be "rung" to that line will sound at exchange ringing cadence, provided the extension is not "off-hook" or in "Divert". If all extensions that are programmed to be rung on that line are either engaged or in divert a "pip" or "click" tone is connected to the intercom circuits.

Any extension can answer an incoming call by lifting the handset and depressing the relevant exchange line button. When the call is answered the exchange line LED will revert to a steady glow.

Programming Exchange Line Ringing

Normally the buzzers at every extension will sound for all incoming calls but each extension user may individually decide which exchange lines will "ring" their telephone. The extension user may check or alter the programmed arrangements as follows:-

- i. leave the handset "on-hook"
- ii. press and maintain the **HOLD** button
- iii. the exchange line LED's indicate the state of ringing for each line. If the LED glows the telephone is programmed to "ring" for that line. If the LED does not glow the telephone will not "ring" to an incoming call on that line.
- iv. operating an exchange line button while the handset is "on-hook" and with the **HOLD** button depressed will reverse the state of ringing on that line. If the exchange line LED is not glowing after the button has been pressed then the instruction to ring has been cancelled. If the LED glows after the button has been pressed then that line will ring at the extension.
- v. release the **HOLD** button.

HOLD

Exchange Line calls may be held by pressing the **HOLD** button. When the **HOLD** button is pressed the telephone is disconnected from the exchange line which is held by the CCU. The exchange line LED flashes at the "HOLD" cadence at all extensions. The extension user may make an intercom call or a call on another exchange line. At the completion of this call the extension user may return to the "Held" exchange line by repressing that exchange line button.

TRANSFER

Both incoming and outgoing exchange line calls may be transferred to other extensions on the system.

The exchange line call is held as described above and an intercom call is set up to the extension to which the call is to be transferred.

When the receiving extension answers and agrees to take the call, the transferring extension should replace the handset on the telephone and the call will then be automatically transferred.

If the receiving extension does not answer, or does not wish to take the call, the transferring extension may speak to the exchange line call again by pressing the appropriate exchange line button. Alternatively another extension on the system may be rung after pressing the telephone switchhooks to clear the first intercom call.

DIVERT

Exchange line calls or intercom calls can be diverted from one extension (the Diverting extension) to another (the Nominated extension), providing:-

- i. the system has been programmed in advance
- ii. the diverting extension is not receiving diverted calls at that time
- iii. the nominated extension is not diverting calls at that time.

To Programme "Divert"

If an extension wishes to nominate another extension to receive diverted calls, slightly different procedures apply depending on the nominated extension number.

To nominate extension 1 to 5:-

- i. leave the handset "on-hook"
- ii. press **both** the **HOLD** and **DIVERT** buttons together and keep both buttons pressed
- iii. The exchange line buttons 1 to 5 represent extensions 1 to 5. Press and release the appropriate button.
- iv. release the **HOLD** and **DIVERT** buttons.

To nominate extension 6 to 10:-

- i. leave the handset "on-hook"
- ii. press **both** the **HOLD** and **DIVERT** buttons together
- iii. keeping the **HOLD** button depressed, release the **DIVERT** button
- iv. The exchange line buttons 1 to 5 now represent extensions 6 to 10. Press and release the appropriate button.
- v. release the **HOLD** button.

The equipment is now programmed although there will be no visual indication of this. To bring the facility into use it is necessary to once again depress and release the **DIVERT** button.

Subsequent operations of the **DIVERT** button will switch off or call-in the facility.

The extension nominated to receive the diverted calls may be changed at any time by programming the new extension using the above procedures.

If required, the 'Divert' facility may be cancelled by programming the extension's own number using the above procedures.

While in "Divert"

- i. The diverting extension can make outgoing exchange or intercom calls but all incoming calls are signalled at the nominated extension.
- ii. A green "Calls Diverted" lamp (LED) beside the **DIVERT** button glows on the diverting telephone and also a green lamp above the keypad on the nominated extension telephone glows. (See Fig. 9.).
- iii. The nominated extension can call the diverting extension on intercom. The diverting extension only receives a single buzz, whether he is "on-hook" or engaged on another call. If the diverting extension is "on-hook" the red lamp (LED) beside the **HOLD** button will glow until the call is answered. This informs the diverting extension that the nominated extension has called.
- iv. Transfer of a held exchange line call to the diverting extension can only take place if the diverting extension presses the appropriate exchange line button.

TEN ADDRESS REPERTORY DIALLING

SENATOR Telephones 8521 have the additional facilities of a ten address repertory dialling unit. Up to 10 exchange line numbers each of up to 18 digits can be stored, one under each button from 1 to 0 of the push button dial unit. There is also the facility to automatically repeat the last number keyed. On these telephones the row of buttons to the left of the push button dial are marked R.T.P. down as in Fig. 17.

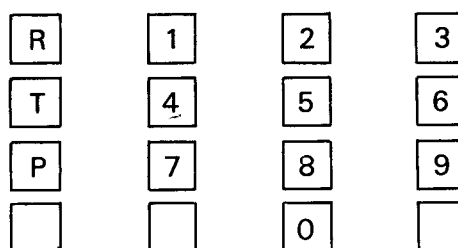

Fig. 17. Typical dial unit keypad.

To store a number

Lift the handset and place it to one side, both hands are needed to operate the correct buttons for this operation.

- i. depress and **hold down** button **P**
- ii. depress and release the digit button under which the number is to be stored, say digit 3
- iii. "key-in" the number to be stored, in the normal fashion, say 01-234 5678
- iv. release button **P**
- v. replace the handset.

In this example exchange line number 01-234 5678 has been stored "under" digit button 3.

Numbers containing up to 18 digits can be stored so most international numbers can be accommodated.

To send a stored number

- i. lift the handset and on receipt of system dial tone depress an exchange line button to seize a free exchange line.
- ii. on receipt of exchange dial tone depress and release button **T**
- iii. depress and release the digit button under which the required number is stored.

To erase a stored number

- i. lift the handset and place it to one side
- ii. depress and hold down button **[P]**
- iii. depress and release the digit button under which the number to be erased is stored
- iv. release button **[P]**
- v. replace the handset.

To change a stored number

It is not necessary to erase a stored number before replacing it with a new number. Keying a new number into the store under a digit button already used replaces the previous number in that store.

Repetition of last number keyed

The last exchange number called by keying in full is stored in the telephone until another exchange number is called. Intercom calls or exchange calls using repertory calling will not effect the stored number. To repeat the last number called:

- i. Lift the handset and listen for system dial tone.
- ii. Select an exchange line by pressing the appropriate exchange line button and listen for dial tone.
- iii. Press **[T]** twice.

INTERCOM CALLS

Any extension on the system may make an intercom call to any other extension by lifting the handset and on receipt of DIAL TONE, keying the required extension number. If the called extension is free the telephone will be buzzed and the calling extension will receive ring tone. When the called extension lifts the handset the intercom call is established. If the called extension is not connected to the system N.U. tone will be received.

6. POWER FAIL ARRANGEMENTS

No provision is made for standby power to maintain the operation of the system if the mains power supply fails.

The relays in the CCU which normally perform the switching of the extension and exchange lines are arranged such that when the power fails, each exchange line is directly connected to certain extensions as follows. (See diagram opposite).

line 1 connects to extn. 1 and 6
line 2 connects to extn. 2 and 7
line 3 connects to extn. 3 and 8
line 4 connects to extn. 4 and 9
line 5 connects to extn. 5 and 10.

Each extension will be able to make or receive calls on the exchange line connected to it. The tone-caller, not the buzzer, will operate to an incoming call but an extension bell connected via a Bell Adapter will not operate. When two extensions are connected to one exchange line, bell-tinkle will be experienced at one telephone when the other dials.

Intercom calls cannot be made during mains failure, nor can calls be transferred. Any programmed facility e.g. "Divert" or "Exchange Line Ringing" will be cancelled and will need to be reprogrammed when power is restored. There will be no visual indications (LEDs) during mains failure.

Short term power disconnexions (between 100 milliseconds and 2 seconds) may cause partial loss of customer-programmed facilities, these may be corrected by turning the power off for 5 to 6 seconds to allow the microprocessor to reset fully. When the power is restored the facilities should be reprogrammed and checked.

Fig. 18.
BLOCK SCHEMATIC
(Part)
SHOWING MAINS
FAIL PATHS.

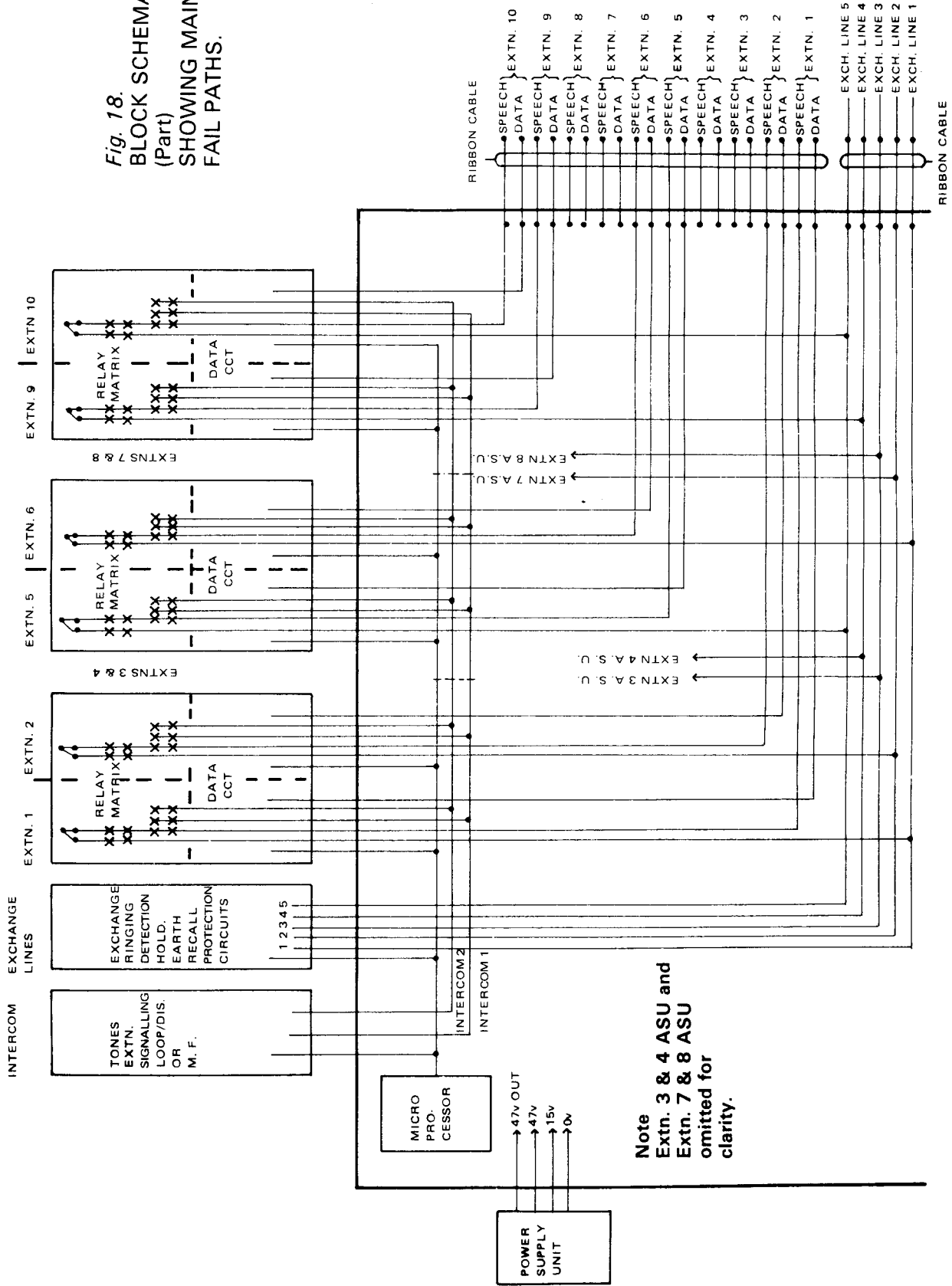

Note
 Extn. 3 & 4 ASU and
 Extn. 7 & 8 ASU
 omitted for
 clarity.

7.

MAINTENANCE

ON SITE MAINTENANCE

In order to restore customer service as quickly as possible, a policy of changing out faulty apparatus should be adopted. On site repair of faulty items should be limited to the replacement of small parts such as transmitter insets.

To provide all the spares required for faulting the CCU, a Maintenance kit should be made up locally. It should consist of the following items.

- one Power Unit
- one Exchange Line ASU
- one Extension Interface ASU
- one Intercom ASU (SC or MF as appropriate)
- one Microprocessor Backplane
- one SENATOR terminal
- spare power fuses

The item codes and descriptions of these items are given in Section 9. A suitable carrying case for the Maintenance Kit will be available shortly (Case 265A).

On site maintenance of SENATOR systems is by functional testing, logic diagnosis, ASU changeout or system replacement.

The mains power supply to the Senator System must be switched off before the Power Unit or an ASU is removed or replaced.

TEST CONDITIONS

The exchange lines test normal DEL conditions but will test "low loop" if a megger test is used.

Testing within the system from a SENATOR telephone towards the CCU both the speech pair and data pair test approx. 45v d.c. The speech and data pairs must not be allowed to come into contact, nor should the data pair be reversed.

Each time a system is powered up, the CCU determines which extensions are spare by testing if a telephone is connected or not. Only those extensions which have a telephone connected are regarded as working extensions, and are "switched on". Number Unobtainable tone is returned to an extension which calls a spare extension.

When a telephone is plugged in to a previously spare extension, that extension will be automatically "switched on" by the CCU, and will work normally. If the telephone is subsequently removed, the extension will remain "switched on" until the system undergoes another powering up sequence.

The CCU does not feed out its 45 volt battery on the A and B wires of spare lines, so if a spare line is tested it may test 'dis'. The CCU is programed, however, to connect an exchange line to each spare extension's line in the same way as would do under mains failure conditions. Therefore a full 50 volt battery will usually be present. The extension will only test 'dis' if the appropriate exchange line has not been provided. For example, if extension 10 were spare, it would test 'dis' only if exchange line 5 were not provided.

FUNCTIONAL TESTING

SENATOR offers a basic range of facilities which should be readily understood by the customer, leading to few mis-operation faults. The customer should have copies of the Senator Extension Users Handbook.

Problems may occur if the mains supply is interrupted as this will cause partial or complete loss of customer-programmed facilities. When a customer reports the loss, either partial or complete, of customer-programmed facilities he should be asked to:-

- i. turn off the mains power for about 5 to 6 seconds.
- ii. when power is restored, reprogram the required facilities.
- iii. retest the facility(ies).

Many maintenance visits may be avoided by adopting this procedure. A description of the facilities is given elsewhere in this book and instruction handbooks (as described above) are supplied for the customer's use.

LOGIC DIAGNOSIS

The logic chart (Fig. 19) will cover most anticipated faults, but may not be complete, nor may it cover obscure or multiple faults.

Before suspecting any of the units within the CCU, ensure that the fault reported is not due to customer misoperation and that all extensions are plugged in and all cabling is undamaged. The data pair to extension telephones is polarity conscious, and if reversed or disconnected will:-

- i. prevent L E D indicators from lighting,
- ii. result in no system dial tone,
- iii. render facility buttons inoperative.

Fig. 19.
FAULTING LOGIC
CHART

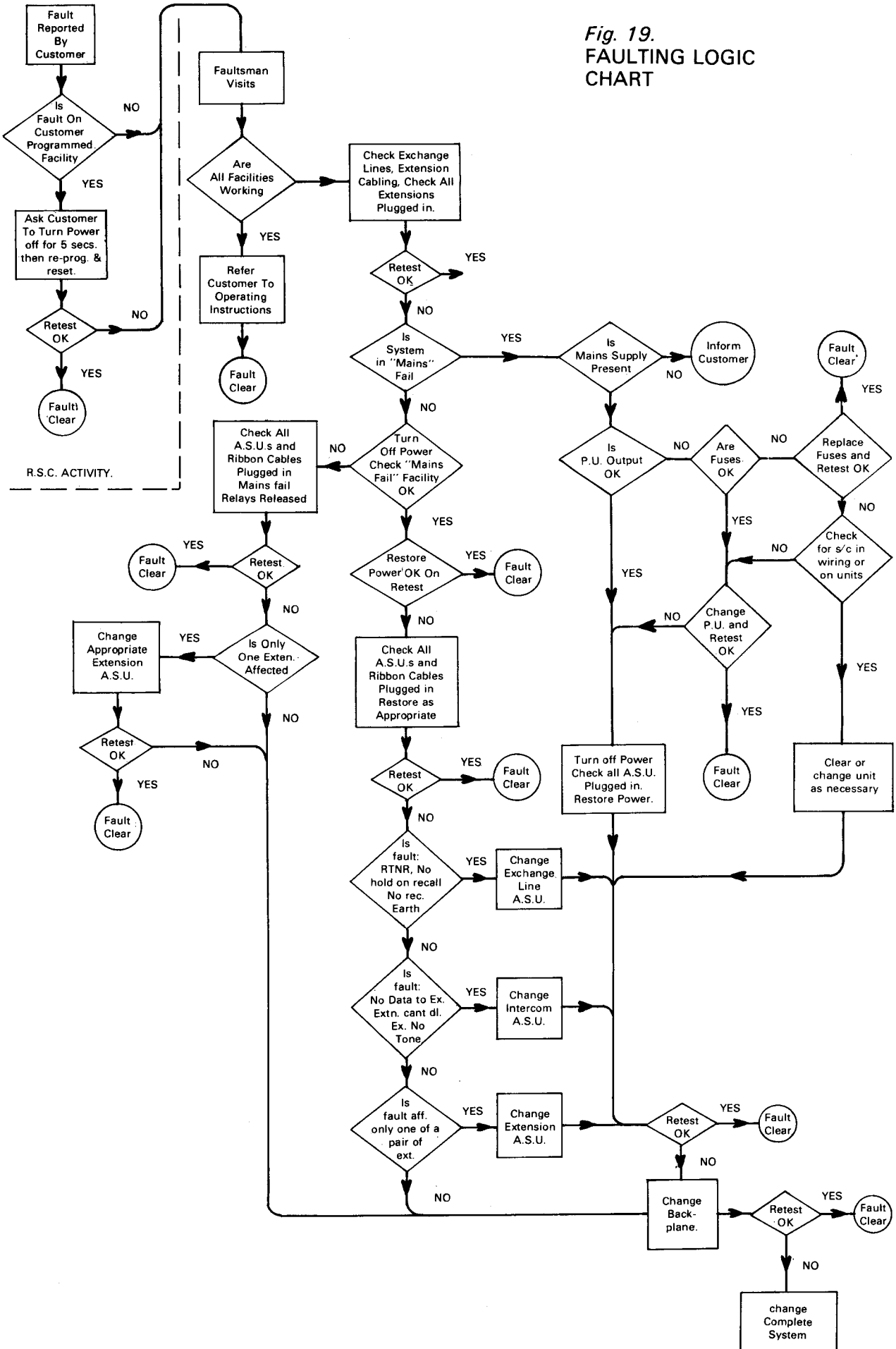

POWER UNITS

Power Unit outputs may be checked by carefully inserting meter multirange probes into the back of the power unit — back plane plug. The meter should be set to the 100v D C scale, the negative probe inserted into pin 4 (the bottom pin) and the voltages checked as follows:-

testing between pin 4 and pin 1 — 47v (fused via FS3)
testing between pin 4 and pin 2 — 47v
testing between pin 4 and pin 3 — 15v

The power unit fuses are mounted in quarter-turn bayonet holders and spare fuses are held in the cover plate below the P.S.U.

The fuses are: Fuse FS 1 (mains input fuse) — fuse 72 /2
 Fuse FS 2 (low voltage output) — fuse 73 /4
 Fuse FS 3 (47v external output) — fuse 72 /0.5

ASU CHANGEOUT

Before removing or replacing a Senator ASU the power supply must be switched off. Precautions must be taken to prevent damage to an ASU by electrostatic discharge.

The three types of ASUs are not interchangeable and the backplane sockets are offset to prevent them being plugged into the wrong position. Early versions of the ASUs had grey handles, but later versions have colour coded handles as follows.

Extension ASU	Yellow handle.
Exchange Line ASU	Blue handle.
Loop disconnect Intercom ASU	Off White handle.
Multi Frequency Intercom ASU	Grey handle.

Extension ASUs may be interchanged within the system to prove faults.

Excessive handling of ASUs should be avoided to prevent damage. They should be held by the edges in much the same way as a long playing record.

BACKPLANE

The backplane contains the system microprocessor and should this fail the entire system is likely to malfunction. The microprocessor controls the mains fail relays, so if a system stays in mains fail even though the power supply outputs are testing correctly a backplane fault should be assumed.

The backplanes contained in Senator Kits 1A, 1B and 1C are not fully interchangeable. They may be replaced on a like-for-like basis, but normally the replacement should be the latest issue which is currently a Senator Backplane 1C. The 'modification state' label on the inside of the CCU cover should be amended to show any changes.

When a 1B backplane is replaced with a 1C backplane the NTPS board (if fitted) will be redundant and should be recovered from Socket 7 on the backplane. Socket 7 is normally used to connect the A.S.U. for extensions 9 and 10. The NTPS board is a temporary measure to overcome 'software' faults in the 1B backplane microprocessor.

ADAPTER UNITS

When an Extension Bell Adapter is proved to be faulty the fuses inside it should be checked and replaced if necessary. If the fuses are not the cause of the fault, the unit should be changed. (See Section 10.1).

A small number of early Senator installations were equipped with Adapter Units for External Extensions and for Inter - P.B.X. circuits. Details of the maintenance procedures for these items are given in Senator News Flashes.

MAINTENANCE EXCHANGE

B.T. gives the customer a 12 month warranty and items which go faulty in this period should be replaced free of charge. Whenever a module has been maintenance exchanged, the replacement item becomes the customers property and the faulty item returns to B.T.

The section stock will "maintenance exchange" the faulty item, which where possible, should be securely packed before being handed to the storeman. Tie-on fault labels should be attached to every unit and completed in full.

Correctly completed fault labels will help to quickly identify any weakness in design or production. If large numbers of items are returned for repair, but faults are not apparent when they are tested, then analysis of the fault labels may lead to design faults being detected.

SYSTEM REPLACEMENT

System replacement should be regarded as the last resort. It is not foreseen that a fault condition will arise to cause all units to fail.

Senator systems are sold outright and so faulty systems may only be recovered when they have been replaced complete. The Central Control Unit must never be transported with the power unit in position as this may strain the mounting lugs and so cause damage.

An A646 should be completed when it is found necessary to change out a complete system. All the units should be returned to Section Stock together so that the repair depot or A646 handling duty may test the complete system.

8. HOW IT WORKS

The system employs normal signalling to the exchange (either public exchange or PBX). Each SENATOR telephone has a standard keypad which can be either self-contained loop-disconnect pulsing (SC) or multi-frequency ac signalling (MF) to suit the type of exchange working. There is no transmission bridge connected into the circuit at the CCU on exchange line calls. The extension is directly connected through to the exchange and this enables items such as Customers' Private Meters to be used at extensions.

The telephones are connected to the CCU by 4-wire connections which are arranged as speech and data pairs. Signals from the keypad and speech signals in the usual form of "varying current" use the speech pair. All other signals use the data pair, and are in the form of coded — 3V pulses superimposed on a standing 50V supply from the CCU power unit.

Briefly, the microprocessor in the CCU continuously monitors the state of incoming exchange lines and the data pairs from the SENATOR telephones. The microprocessors in the telephones monitor the incoming data pairs from the CCU and the state of the gravity switch springs and the "function" buttons. Any change in the state of these is detected, causing an interchange of information within the system, which is used to process the call.

The mains driven power unit within the CCU supplies:-

- i. all the power required by the CCU.
- ii. power to the microprocessor, LEDs and buzzer at each telephone, this power being fed to the telephone over the data pair.
- iii. power for the speech circuit and keypad at each telephone on intercom calls, this power being fed to the telephone over the speech pair.

The power feed at each telephone contains a diode to protect the microprocessor circuitry against damage in the event of a reversal of the data pair. However under these circumstances a complete failure will result as there is no "constant polarity" circuit provided.

The power circuit in the telephone contains a series regulator to control the voltage and a high impedance filter to block data signals from the power supply. All power supplies are generated by constant current circuits to prevent fluctuations in the dc supply caused by the operation of the LEDs or buzzer, being detected as false data signals.

The system is designed to provide for up to 5 + 10 size of installation. Although the system sizes may differ the microprocessors in all CCUs are programmed on the assumption that all systems have ten extensions. Where there are less than 10, "padding routines" are included in the programme, to replace the "missing" extensions so keeping the operating cycle of the microprocessor the same in all systems. The "padding routines" are added or taken away automatically within the microprocessor as extensions are recovered or provided.

The CCU generates two tones, one of 350 Hz and one of 440 Hz which are used to provide all the tones required by the system. The CCU also controls the signals which are used to light the LEDs and operate the buzzers.

9. PARTS LIST FOR "SENATOR"

DESCRIPTION	ITEM	ITEM CODE
Fully Equipped CCU	Senator Kit 1C	37 4773
CCU Housing, including Backplane, Case, Front Cover, Termination Board Assembly	Senator Equipt. 1C	
Microprocessor Backplane	Senator Backplane 1C	37 4774
Power Supply Circuit Board	Senator Circuit Board DPA 1213A	37 4219
Power Supply Module	Senator Power Module D141073A	37 4220
Extension Line ASU	Senator ASU DPA 1209A	37 4221
SC Intercom ASU	Senator ASU DPA 1210A	37 4222
MF Intercom ASU	Senator ASU DPA 1217A	37 4223
Exchange Line ASU (5 lines)	Senator ASU DPA 1207A	37 4224
Extension Bell Adapter	Senator Adapter SA 10255	37 4226
MF Terminal (Brown)	Senator Telephone 8530 (Brown)	37 4228
MF Terminal (Stone)	Senator Telephone 8530 (Stone)	37 4229
SC Terminal (Brown)	Senator Telephone 8520 (Brown)	37 4232
SC Terminal (Stone)	Senator Telephone 8520 (Stone)	37 4233
SC 10 Address Terminal (Brown)	Senator Telephone 8521 (Brown)	37 4234
SC 10 Address Terminal (Stone)	Senator Telephone 8521 (Stone)	37 4235
Fuse FS1	Fuse 72 /2	31 4209
Fuse FS2	Fuse 73 /4	31 4004
Fuse FS3	Fuse 72 /0.5	31 4216
Battery, Dry	Battery Dry No. 102	17 1411

10. AUXILIARY EQUIPMENT

10.1 EXTENSION BELLS

If an extension bell is required at an extension, or if the tone-caller in the telephone is required to sound instead of the buzzer, an Extension Bell Adapter SA 10255 is required. It is capable of ringing ONE high impedance extension bell only.

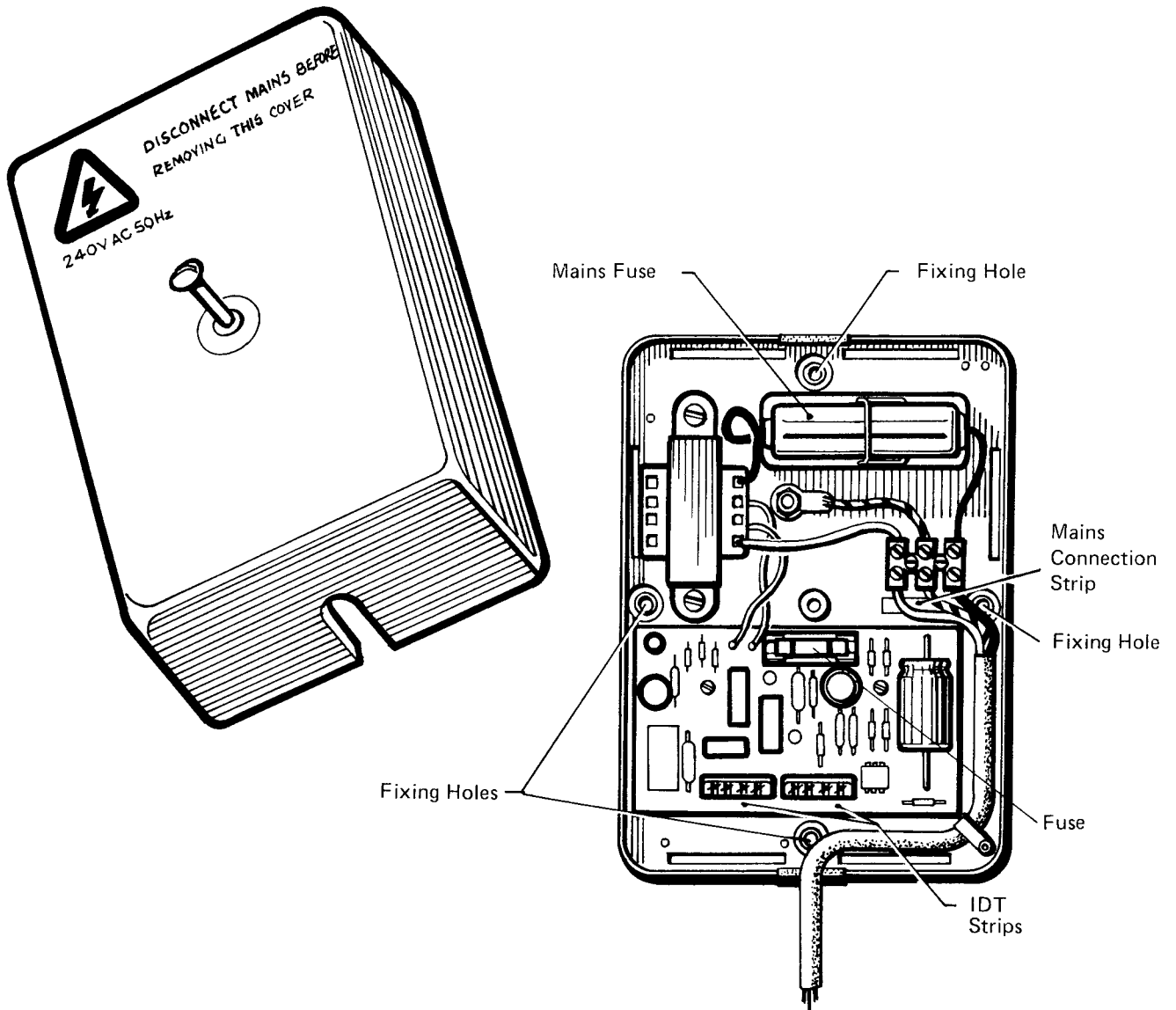

Fig.20 Extension Bell Adapter

When an Adapter is fitted to an extension the buzzer in the telephone will normally be inoperative, and all incoming calls to that telephone will be signalled by the tone-caller in the telephone as well as by the extension bell.

Installation Details for Extension Bell Adapter

The Extension Bell Adapter should be fitted as close to the extension telephone as possible, but bearing in mind that the Adapter is mains powered and must be positioned close to a suitable socket outlet.

The cable to the extension from the CCU must be terminated on the Adapter, and a 6 wire cable, Cable Equipment 2503F, should then be run to the telephone socket. The extension bell may be wired to the Adapter or to the telephone socket as convenient. (See Wiring Diagram opposite).

At the extension telephone the 4 wire line cord should be changed to a 6 wire type, Cord Conn. 6/500. Inside the telephone, Link "A" must be disconnected. The link which is a 'safety pin' type as shown in the illustrations below, is located on the underside of the printed circuit board module which supports the facility buttons. Take care not to disturb any ribbon cable connexions.

Fig. 21. Link A

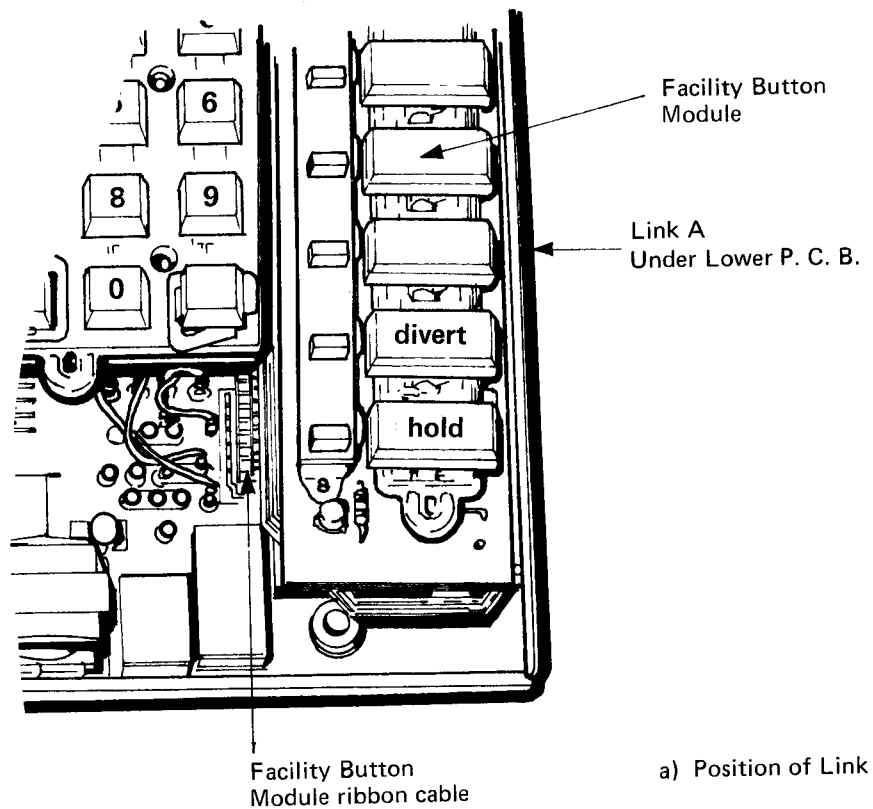

a) Position of Link "A"

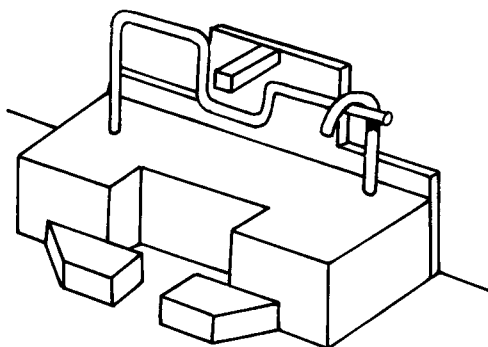

b) Link "A" connected (closed)

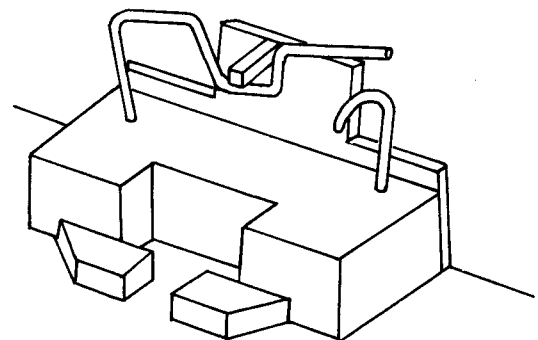

c) Link "A" disconnected (open)

Fig. 22 CONNEXION OF EXTENSION BELL ADAPTER

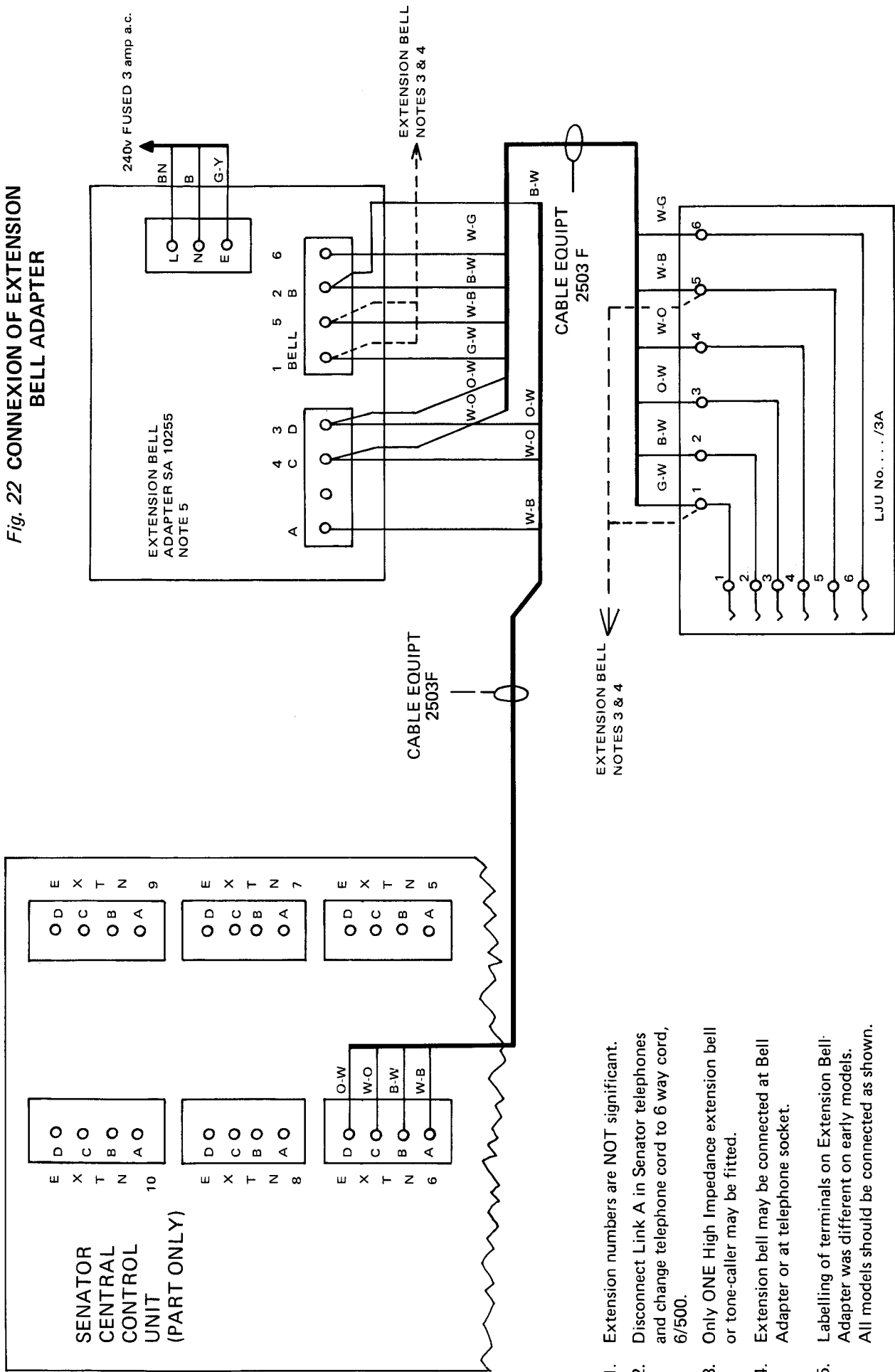

- NOTES
1. Extension numbers are NOT significant.
 2. Disconnect Link A in Senator telephones and change telephone cord to 6 way cord, 6/500.
 3. Only ONE High Impedance extension bell or tone-caller may be fitted.
 4. Extension bell may be connected at Bell Adapter or at telephone socket.
 5. Labelling of terminals on Extension Bell-Adapter was different on early models. All models should be connected as shown.

Maintenance of Extension Bell Adapters

Extension Bell Adapter Units contain transistorised circuits mounted on printed circuit boards and are not suitable for repair in the field.

When a unit is proved to be faulty its fuses should be checked, changed if necessary, and if the unit is still faulty it should be replaced with a maintenance spare. The fuses used are as follows:-

FS 1 (Mains Fuse) 50 mA A/S Fuse 36A/0.05

FS 2 (Output Fuse) 100 mA Q/B Fuse 73/0.1

When an extension bell is fitted the adapter unit provides the ringing current to both the extension bell and to the tone-caller in the telephone. The buzzer in the telephone will normally be inoperative, so if the adapter unit develops a fault it is likely that no audible indication of an incoming call will be given at the extension. The latter fault could be due to a fault in the CCU or wiring however, but if the exchange line LEDs on the telephone flash for incoming exchange line calls then the adapter unit is probably faulty.

Extension bell adapter units may be tested in the following way:-

- i. Disconnect the mains supply to the unit.
- ii. Disconnect the wiring to the CCU, telephone and extension bell (if connected at the unit).
- iii. Connect a high impedance bell across terminals JL1 and JL5.
- iv. Connect short lengths of wire to terminals JL4 and JL6.
- v. Replace cover and reconnect mains supply.
- vi. Connect a **1.5 v** battery to the wires fitted in 'iv' above as follows:

+ve to JL6
-ve to JL4

When the battery is connected the relay in the unit should be heard to operate, and the bell should ring to the 60v 25 Hz. output.

All faulty units should be returned to the section stock in the packing of the replacement unit, and should have a label attached giving the details of the fault.