

British

TELECOM

System manual

Senator

British
TELECOM
System manual

Senator

British Telecommunications plc

Published by British Telecom Technical Publications.

All possible care has been taken in the preparation of this publication, but British Telecommunications plc accepts no liability for any inaccuracies that may be found.

British Telecommunications plc reserves the right to make changes without notice both to this publication and to the product which it describes.

If you find any errors in this publication or would like to make suggestions for improvement, please write to:

BT Technical Publications
1st Floor
Anzani House
Trinity Avenue
FELIXSTOWE
Suffolk
IP11 8XB

Telex: 987062 BTANZ G
Fax: 0394 693257

© **British Telecommunications plc 1988**

No part of this publication may be reproduced, transmitted, transcribed, stored in a retrieval system or translated into any human or computer language in any form by any means without the prior permission of British Telecommunications plc.

British Telecom is a registered trade mark of British Telecommunications plc.

British Telecommunications plc
Registered Office 81 Newgate Street LONDON EC1A 7AJ
Registered in England No 1800000

Printed in the UK

Issue number 2 (12/88)
Publication number CPE/MS 526

SENATOR SWITCHING SYSTEM

Contents	Page	
Part 1	General Description	1.1
Part 2	Installation	2.1
Part 3	The Terminal	3.1
Part 4	Commissioning Procedures	4.1
Part 5	Facilities and Operating Procedures	5.1
Part 6	Power Fail Arrangements	6.1
Part 7	Maintenance	7.1
Part 8	How it Works	8.1
Part 9	Parts List of Current Equipment for 'Senator'	9.1
Part 10	Auxiliary Equipment	10.1
Part 11	Documentation	11.1
Part 12	Specification	12.1

SENATOR SWITCHING SYSTEM

Part 1 GENERAL DESCRIPTION

The SENATOR Switching System is a microprocessor controlled system which can have up to five exchange or PBX lines and up to 10 extensions connected to it. (5 + 10).

It uses dedicated telephones, Tele 85xx (see Fig 1), with plug and socket connections to all cordage. The telephones are connected by four wires to a Central Control Unit (CCU) which houses the system power unit, the main elements of the control circuits and terminations for the lines.

The CCU has a power consumption of 200 watts and the customer must provide a suitable 13A mains socket outlet for it.

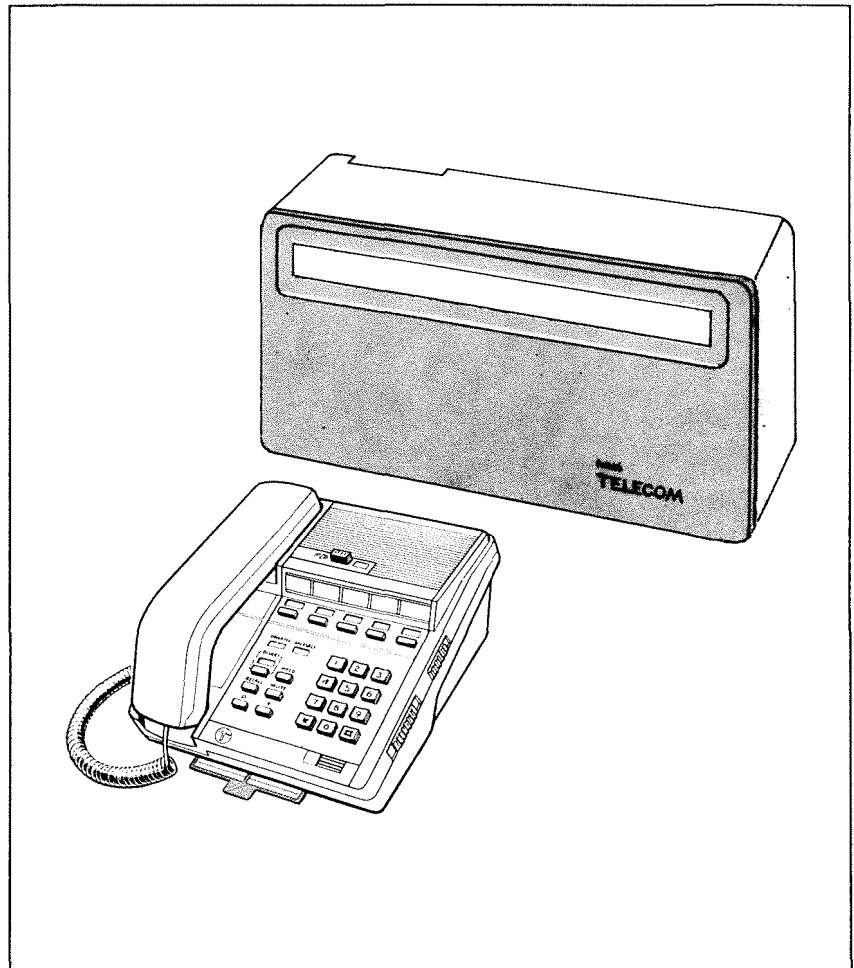

Fig 1. SENATOR TELEPHONE AND CENTRAL CONTROL UNIT

SENATOR is available for LOOP DISCONNECT or MF4 signalling systems and can be used on any of the following lines:

- DELS - exclusive only
- PBX extensions - with or without earth loop recall
- Private circuits

SENATOR CANNOT be used on PBX extensions which use 'C' wire.

Part 1 GENERAL DESCRIPTION

Part 2 INSTALLATION

Contents		Page
2.1	THE CENTRAL CONTROL UNIT	2.3
2.2	INSTALLING THE CCU	2.4
2.2.1	Preparation	2.4
2.2.2	Fitting the rear mounting assembly	2.4
2.3	FITTING THE POWER SUPPLY UNIT (PSU)	2.5
2.4	FITTING THE APPARATUS SLIDE-IN UNITS	2.7
2.4.1	Refit the case	2.7
2.4.2	Fitting the apparatus slide-in units (ASU)	2.7
2.5	CABLING	2.8
2.6	EXCHANGE LINE AND EXTENSION WIRING	2.11

Part 2 INSTALLATION

Part 2 INSTALLATION

2.1 THE CENTRAL CONTROL UNIT

The CCU is equipped as follows:

CCU Housing Assembly, comprising:

- a) Rear Mounting Assembly
 - b) Case
 - c) Front Cover
-
- One microprocessor board (Backplane)
 - One Line Termination board
 - One Power Supply Unit
 - One 5-Exchange Line ASU
 - Three 2-Extension Line ASUs

An Intercom Apparatus Slide-in Unit (ASU) (either Loop/Dis or MF, as required) must be requisitioned separately, as must any additional Extension Line ASUs that are required for the system.

The Rear Mounting Assembly, see Fig 2.1, contains the 'Backplane' which is the main printed circuit board (PCB) carrying the microprocessor circuitry sockets for up to seven Line/Intercom ASUs and a secondary PCB which carries the termination blocks for exchange line and extension cable terminations. The CCU must never be transported with the Power Supply Unit in position as this will strain the mounting lugs and so cause damage.

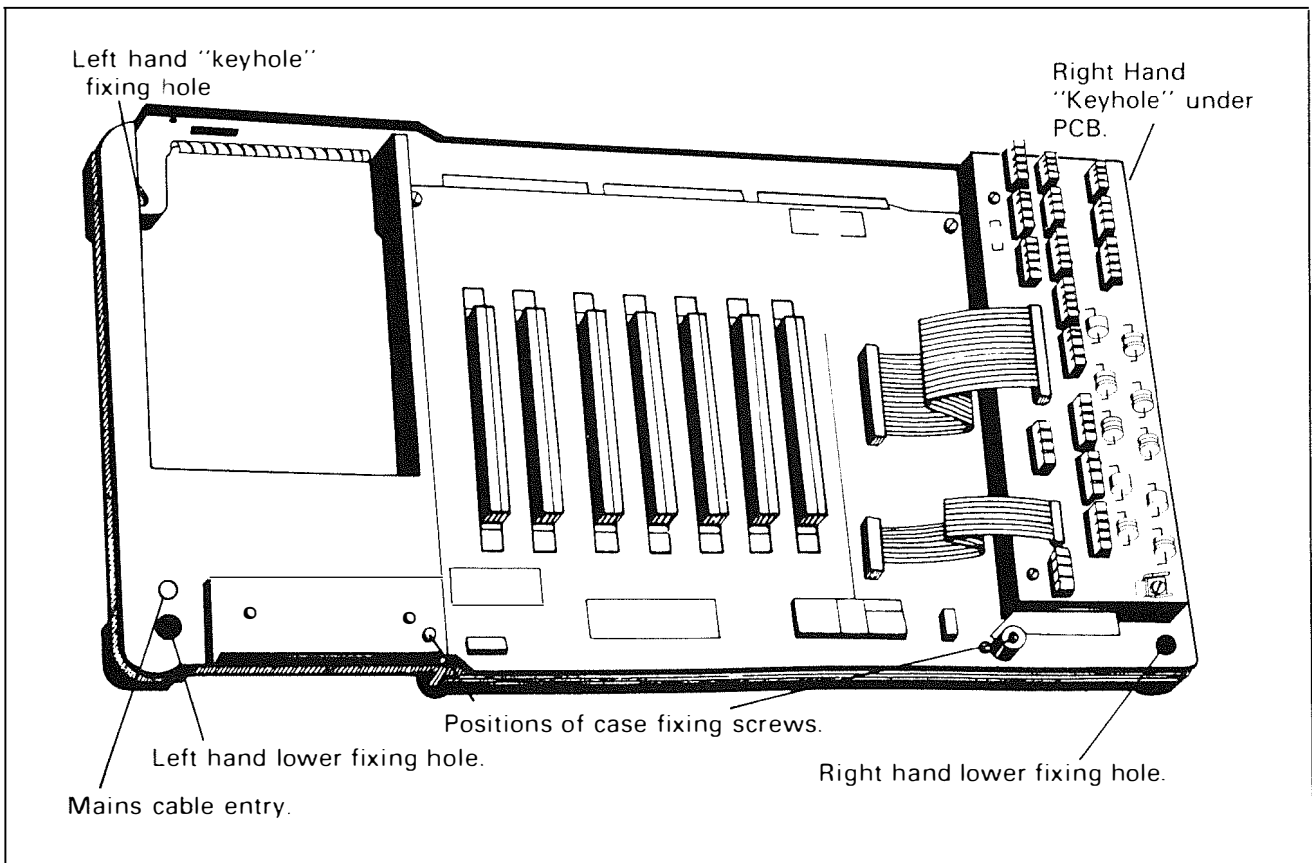

Fig 2.1 REAR MOUNTING ASSEMBLY

Part 2 INSTALLATION

2.2 INSTALLING THE CCU

The CCU should be wall mounted on a suitable flat, sound surface. This should be within 3m of a mains socket outlet and should allow the CCU to be clear of the floor and any obstructions. It should not be installed in the vicinity of any equipment liable to cause radio frequency interference e.g. arc welders etc.

2.2.1 Preparation

First remove the front cover and the case from the rear mounting as follows:

- Remove the fixing screws in the top left and right hand corners of the front cover.
- Ease the top of the front cover away from the case, lift the cover clear and disengage the lugs from the slots in the case.
- With the cover removed, remove the two screws holding the case to the rear mounting, see Fig 2.1.
- Ease the lower edge of the case away from the rear mounting, lift the case clear and disengage the lugs from the slots at the top of the rear mounting.

2.2.2 Fitting the rear mounting assembly

- Drill and plug two holes, for No.10 woodscrews, at a suitable height above the floor or any obstruction. The two holes must be 495 mm apart horizontally.
- Fit, but do not fully tighten, No.10 woodscrews into these plugged holes.
- Offer the rear mounting assembly to the wall so that the two screws enter the 'keyholes' in the top corners of the assembly. Slide the mounting so that the screws are in the slotted portion of the 'keyhole'.
- Check that the mounting assembly is horizontal and adjust if necessary. Mark the wall through the lower fixing holes.
- Remove the rear mounting assembly from the wall, drill and plug the lower fixing holes for No.10 woodscrews.
- Feed the free end of the mains cable through the entry hole in the rear mounting assembly from the rear, see Fig 2.1. Leave about 220mm of cable free at the front of the mounting assembly.
- Refit the rear mounting assembly to the wall and tighten all fixing screws.

Part 2 INSTALLATION

2.3 FITTING THE POWER SUPPLY UNIT (PSU)

- Remove the two countersunk screws fitted in the top surface of the PSU. Keep these screws handy, ready to fix the PSU in place.
- With the voltage selector towards the front, fit the tab on the rear of the PSU into the slot at the left-hand side of the rear mounting assembly.
- Pivot the PSU on the tab to swing into the rear mounting assembly.
- Align the screw holes in the top surface of the PSU with holes in the rear mounting assembly.
- Replace and tighten the two countersunk screws through the holes in the rear mounting to secure the PSU.

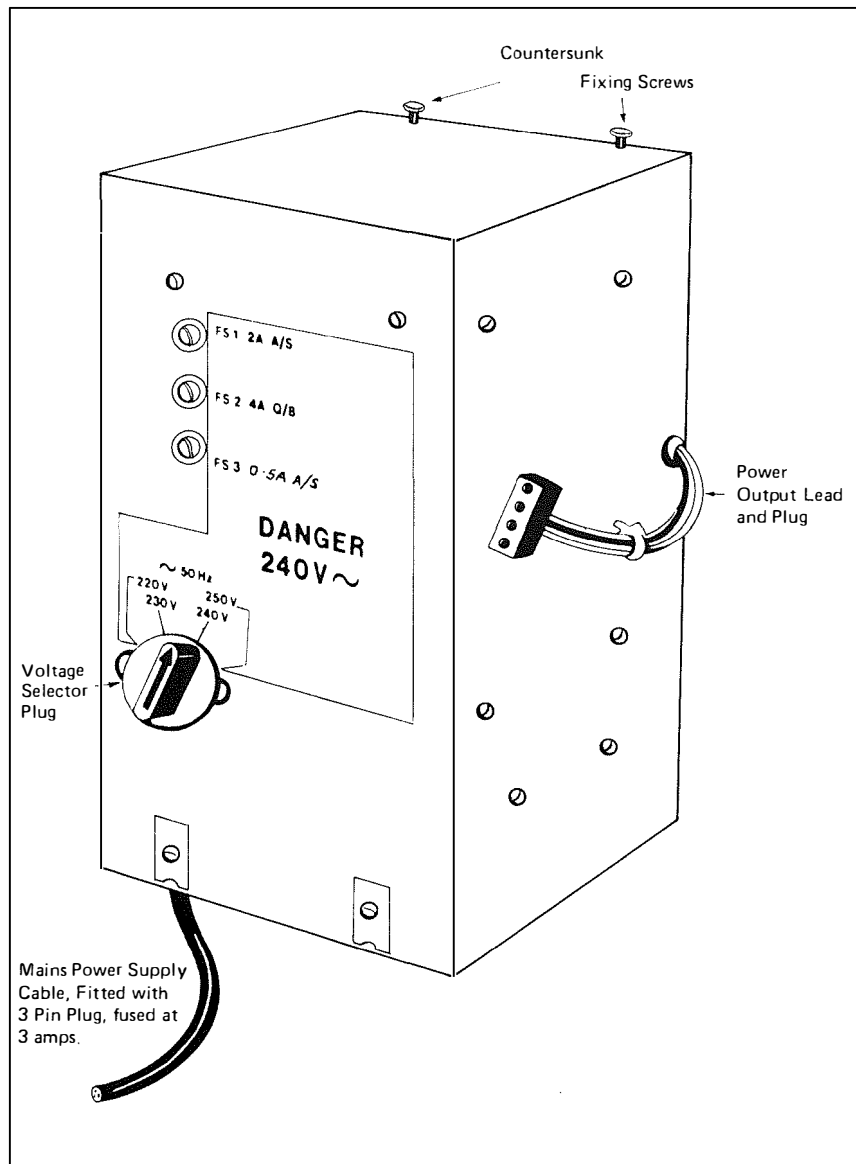

Fig 2.2 POWER SUPPLY UNIT (PSU)

Part 2 INSTALLATION

- Connect the mains cable to the PSU. A mains cable, not more than 3m long must be obtained locally, and terminated to the terminal block which with its associated cable clamp is mounted in the bottom of the PSU. See Fig 2.3.
 - a) Remove the self-tapping screws which hold the cable clamp to the terminal block. Turn the clamp through 90°.
 - b) Fit the mains cable into the clamp allowing sufficient cable to project to allow for terminating.
- Terminate the mains cable to a 13 amp 3 pin plug, fused at 3 amps, following the standard colour code:
 - Brown to 'L' or LIVE
 - Blue to 'N' or Neutral
 - Green-Yellow to 'E' or Earth

Do not plug in at this stage.

- Insert the power unit output plug into the socket provided on the 'Backplane'. The plug is polarised and can only be inserted one way.
- Set the voltage selector to the correct input voltage which will normally be 240V. The voltage selector is NOT A SWITCH but a plug. It should be unplugged, turned to the required voltage setting and then pushed home.

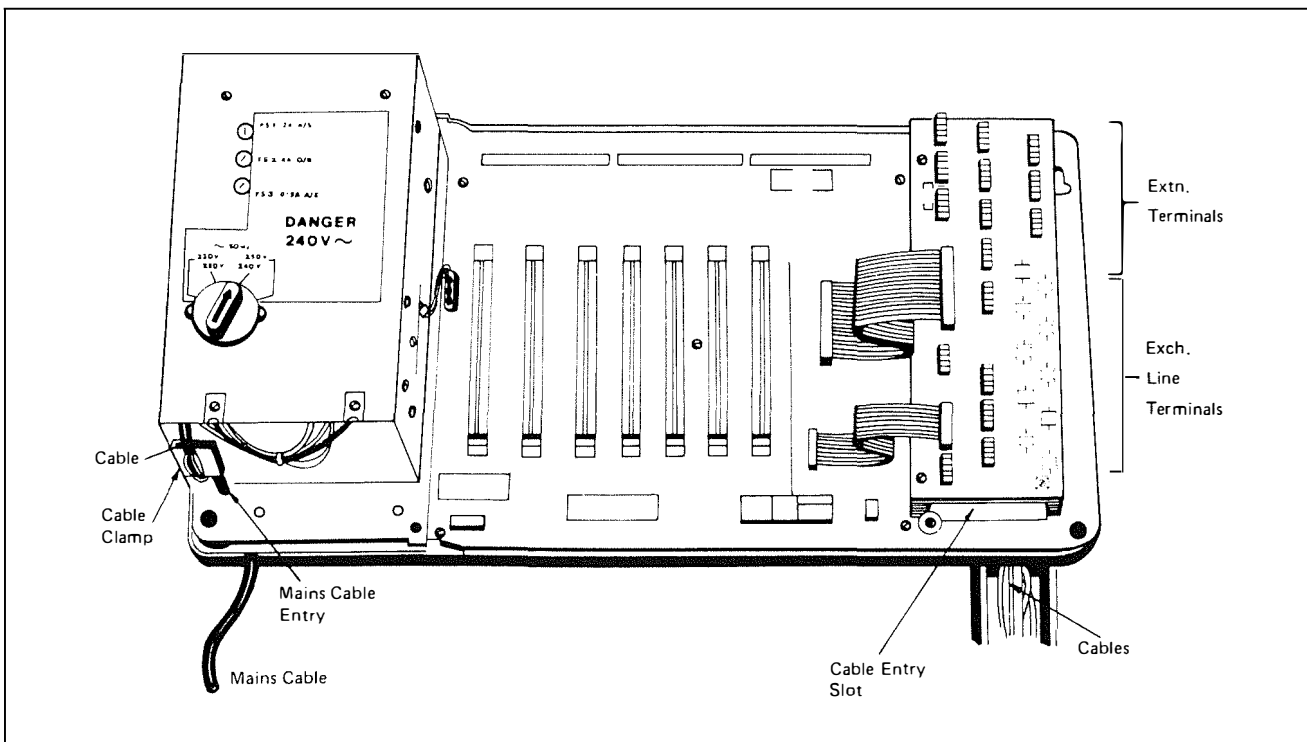

Fig 2.3 PSU IN POSITION ON REAR MOUNTING ASSEMBLY

Part 2 INSTALLATION

2.4 FITTING THE APPARATUS SLIDE-IN UNITS

If it is more convenient, the exchange line and extension cables may be terminated on the CCU before the rest of the CCU is assembled. (See Sections 2.5 and 2.6.)

2.4.1 Refit the Case

The case should now be refitted to the rear mounting.

- Engage the lugs in the upper rear of the case with the slots in the rear mounting.
- Swing the case into position.
- Fit and tighten the case fixing screws.
- Fit the plate carrying the spare fuses in their carriers to the screws at the lower edge of the PSU. This plate covers the gap between the PSU and the case to prevent accidental contact with the mains connections. (See Fig 2.5.)

2.4.2 Fitting the Apparatus Slide-in Units (ASU)

The Exchange Line ASU, the Intercom ASU and the Extension ASUs can now be fitted. Each is carefully slid into its respective guide as in Fig 2.4. Ensure that the card is positioned correctly before fully pushing it into its socket. The positions for the ASUs are shown in Fig 2.5.

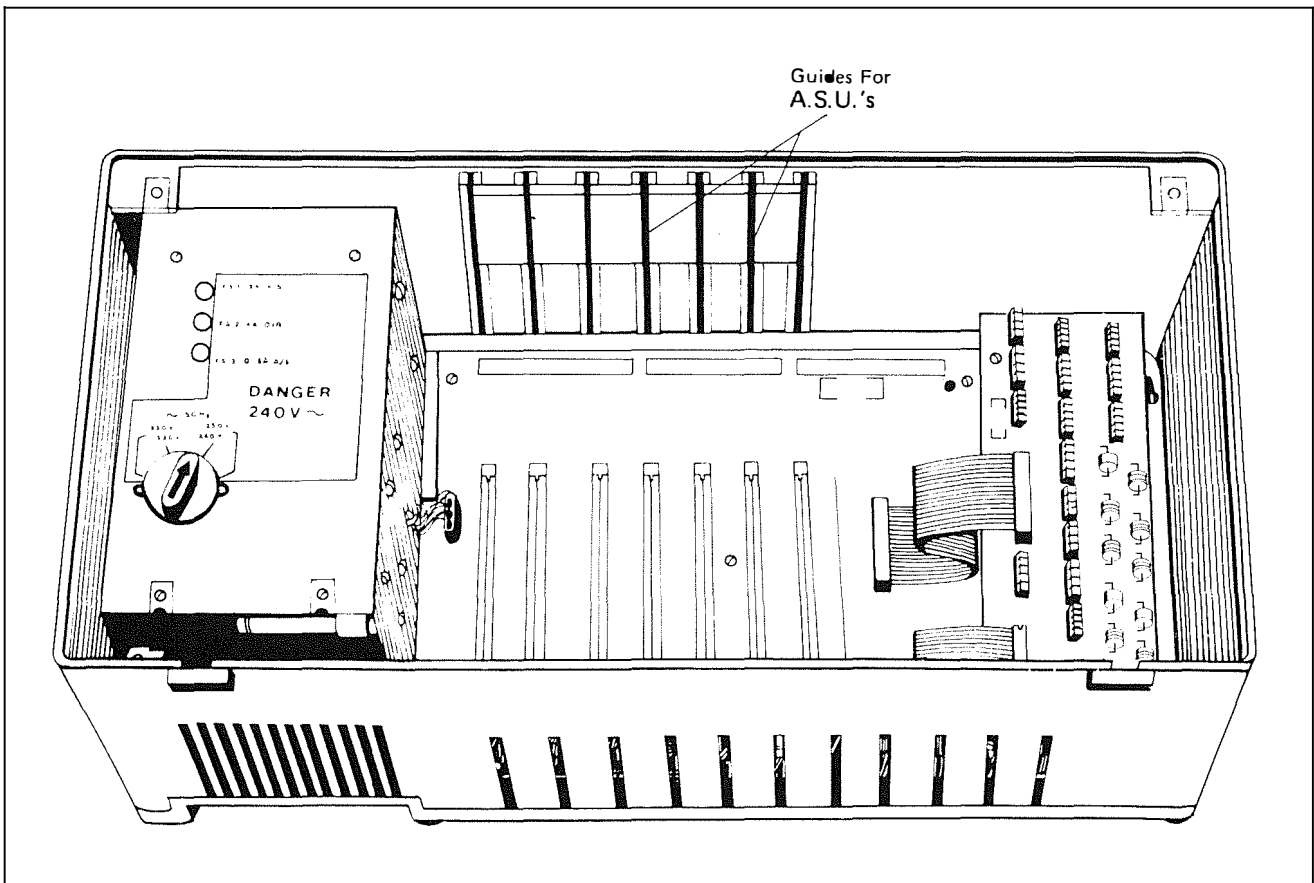

Fig 2.4 CCU WITH CASE IN POSITION

Part 2 INSTALLATION

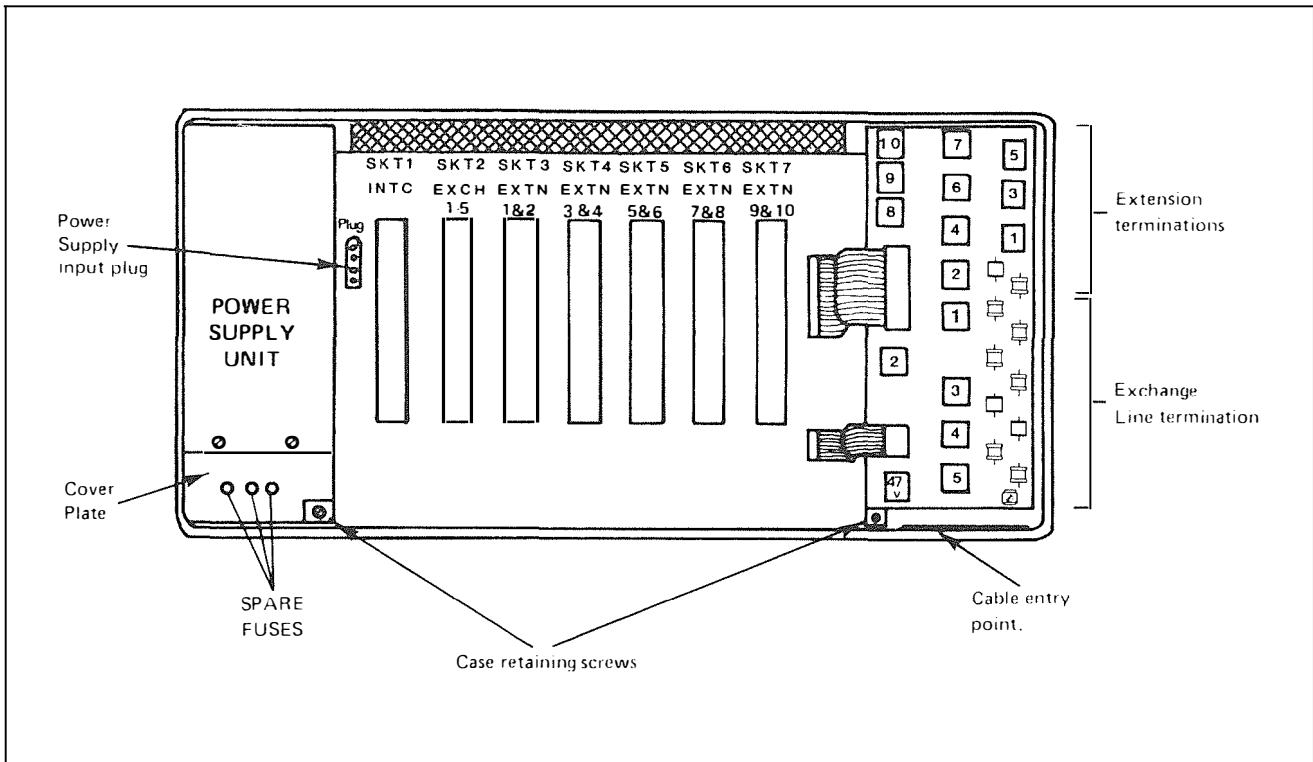

Fig 2.5 CCU LAYOUT

SKT

1	INTERCOM ASU (DPA 1210/A (LOOP/DIS) OR DPA 1217/A (MF4))
2	EXCHANGE LINE ASU (DPA 1207/A (5 LINES))
3	EXTENSIONS 1 - 2 ASU (DPA 1209/A)
4	EXTENSIONS 3 - 4 ASU (DPA 1209/A)
5	EXTENSIONS 5 - 6 ASU (DPA 1209/A)
6	EXTENSIONS 7 - 8 ASU (DPA 1209/A)
7	EXTENSIONS 9 - 10 ASU (DPA 1209/A)

NOTE

Orange handled extension ASU is installed when inter PBX adaptor is used.

2.5 CABLING

SENATOR uses four wires between the telephone sockets (LJU No ../3A) and the CCU. The four wires comprise two speech wires and two data wires.

It has been found that quad formation four wire cables cause overhearing between the speech and data pairs so although two wires are spare, 6-wire Cable Equipment 2503F must be used because it is of twisted pair formation, and therefore free of the overhearing problem.

A maximum loop resistance of 250 ohm is permitted between an extension and the CCU. Using 0.5 mm conductors this is the equivalent of a route length of 1.5km of cable.

Part 2 INSTALLATION

Where an earth is required for PBX recall, a bunched 0.5mm cable pair should be run from the local functional earth to the E terminal on the exchange line connectors on the CCU backplane. The mains protective earth must not be used for this purpose. If terminal board DPA 1374 is fitted, then a permanent earth connection using 1.5mm sq earth wire (Wire/Earthing 9141/1W Item code 033568 or 9142/1W Item code 033569) should be made between the earth screw terminal to a proven building earth point. This wire is in addition to any earth provided for recall.

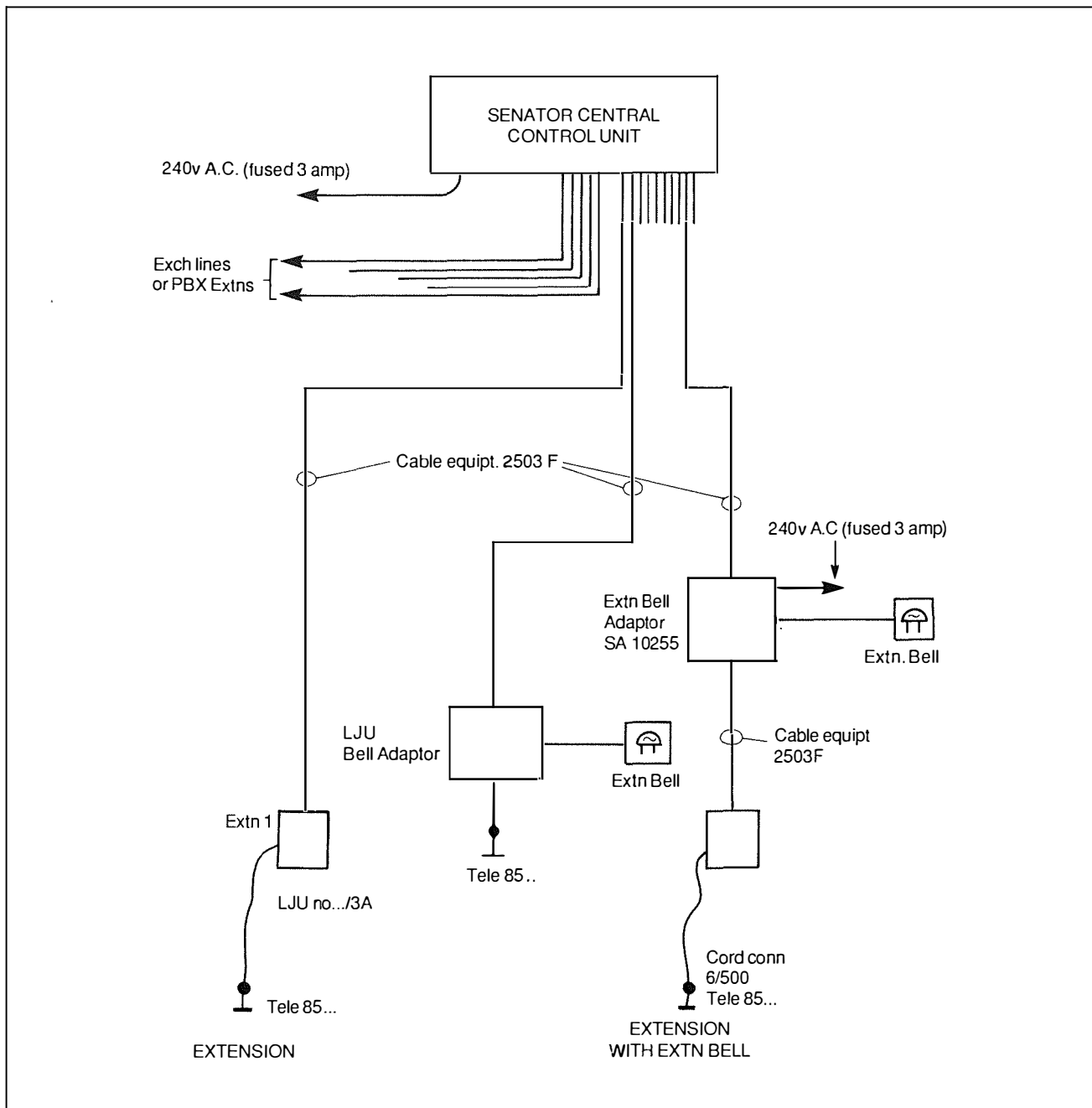

Fig 2.6 TYPICAL LAYOUT AND CABLING FOR SENATOR

Part 2 INSTALLATION

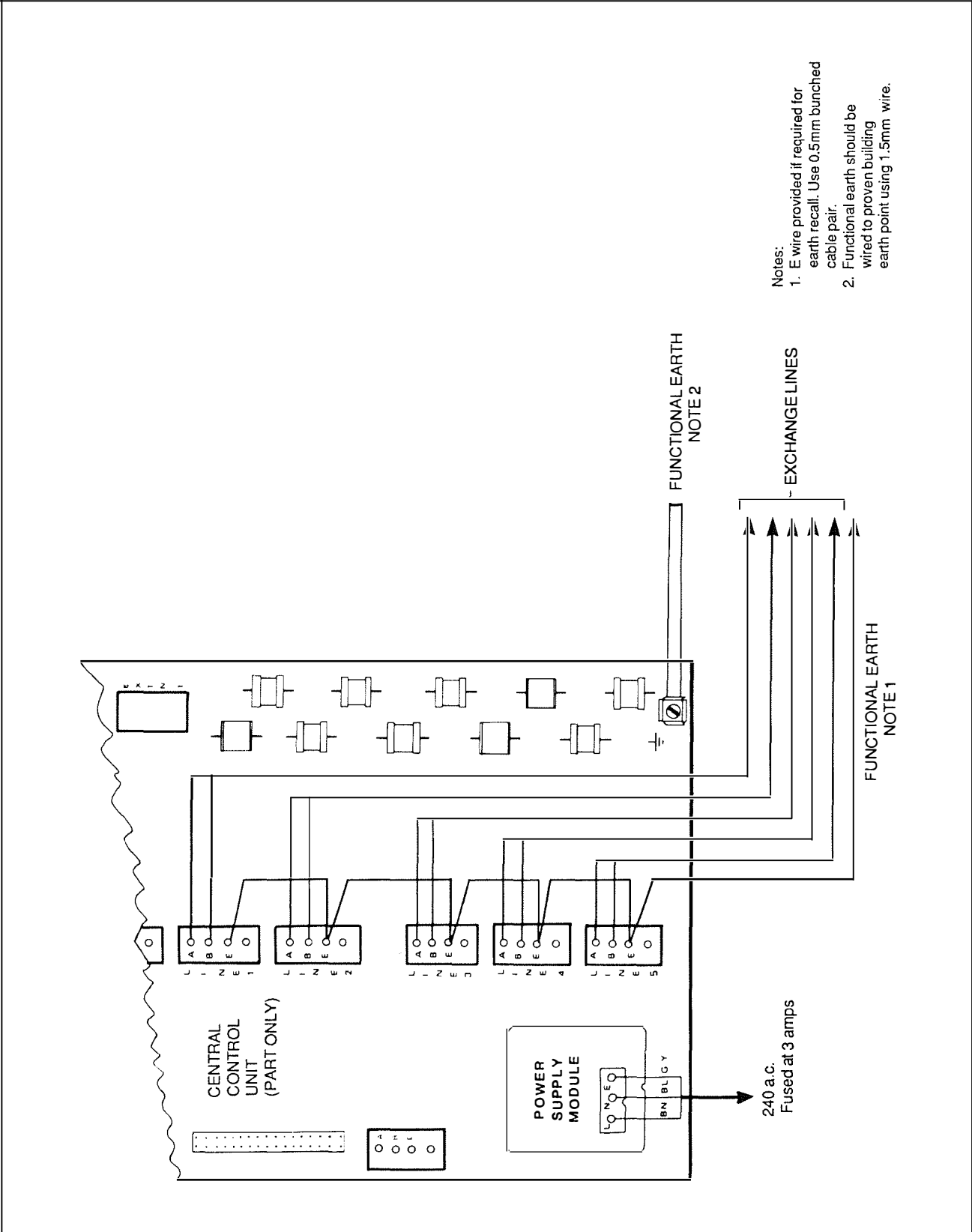

Fig 2.7 'SENATOR' CONNECTION OF A.C. POWER, EXCHANGE LINES AND EARTHS

Part 2 INSTALLATION

2.6 EXCHANGE LINE AND EXTENSION WIRING

The cables bringing exchange lines and extension connections to the CCU should be fed under the rear mounting plate to enter the CCU through the slot in the bottom right-hand corner, see Fig 2.5. All extensions must use 'twisted pair' type cable: Cable Equipment 2503F (6 wire). All cables are terminated on insulation displacement connections using an Inserter Wire 2A. The cable should be run directly to the Line Jack from the Senator Back Plane. The two spare wires should be insulated and must not be used to connect other circuits, unless otherwise specified.

Terminate the exchange lines and extensions on all appropriate connector blocks. These are labelled on the PCB.

Note that exchange line blocks have three terminals, these being A and B wires and Earth (used for PBX recall). Extension blocks have four terminals, A and B being the speech pair, C and D the data pair. The data pair and speech pair must not be transposed nor must the data pair be reversed wire for wire.

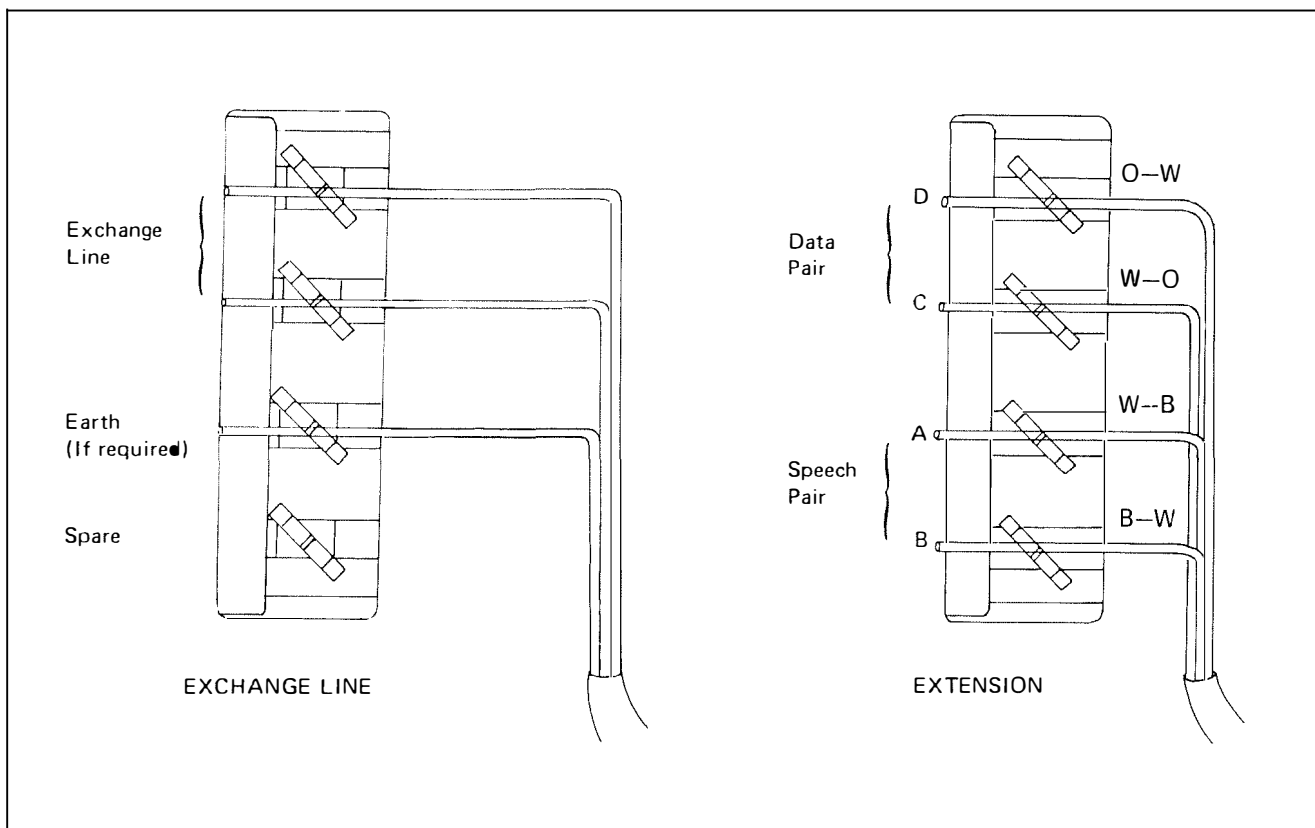

Fig 2.8 TERMINATION OF EXCHANGE LINE AND EXTENSION CABLES.

The cables at each extension should be terminated onto an LJU No..../3A. (see diagram over).

Part 2 INSTALLATION

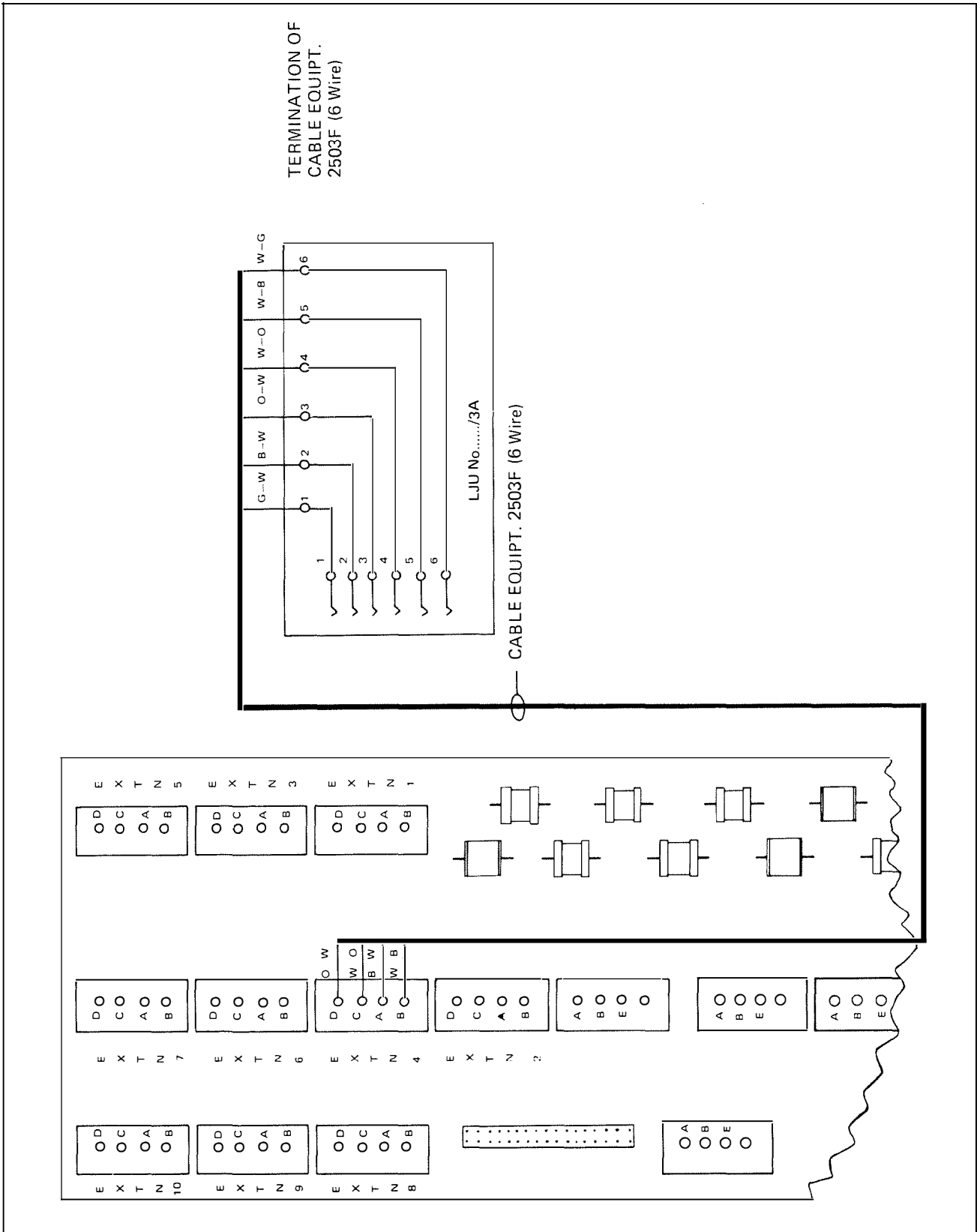

Fig 2.9 CONNECTION OF SENATOR EXTENSIONS

Part 3 THE TERMINAL

Contents		page
3.1	SENATOR 10 AND SENATOR SUPER 10	3.3
3.2	REFURBISHED TERMINALS	3.4
3.3	OLD VERSIONS OF SENATOR TERMINAL	3.4
3.3.1	Handset No 16	3.4

Part 3 THE TERMINAL

Part 3 THE TERMINAL

3.1 SENATOR 10 AND SENATOR SUPER 10

The terminal instrument is available in two versions:

Senator 10 (Tele 8560) and Senator Super 10 (Tele 8561).

Senator 10 (light grey) has customer switchable LD/MF signalling and earth or timed break recall. Other facilities include 10 repertory stores, last number redial, tone caller volume switch, speech mute, cord storage, wall mounting and an information card for repertory dialling.

The seven function keys on the older style terminals have been replaced by a group of five blue buttons for the exchange lines, with the hold and divert keys and their associated LEDs being grouped with the other secondary function keys.

NOTE

A template for wall mounting is included in the user guide and screws with wall plugs are provided with each terminal.

Senator Super 10 (dark grey), has the same facilities as Senator 10, with the addition of full hands free working. The terminal has a mechanical latching button for loud speech operation which is linked to the hookswitch plunger. On the side of the terminal there is a sliding control to vary the volume of the loudspeaker.

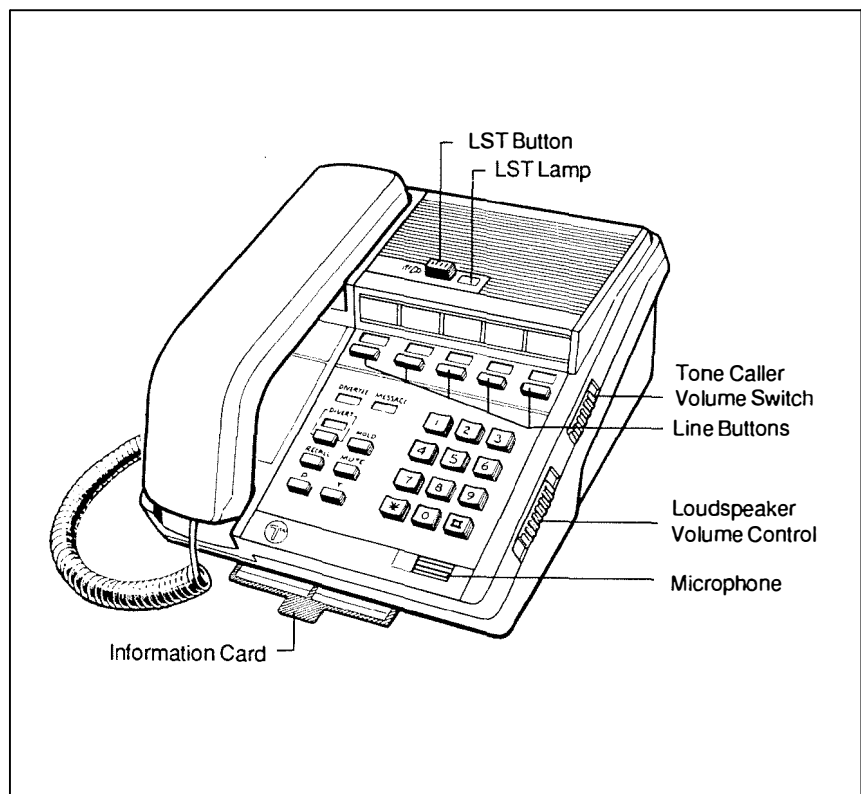

Fig 3.1 TELE 8561

Part 3 THE TERMINAL

3.2 REFURBISHED TERMINALS

Refurbished SENATOR terminals which are available in either brown or stone are:

SENATOR Telephone 8550 (LD) - loop/disconnect signalling

SENATOR Telephone 8530 (MF) - multi-frequency signalling

SENATOR Telephone 8551 (LD) - 10 address repertory dialling
loop/disconnect signalling

SENATOR Telephone 8553 (LD) - 10 address repertory dialling
loop/disconnect signalling

SENATOR Telephone 8520 (LD) - loop/disconnect signalling

SENATOR Telephone 8521 (LD) - 10 address repertory dialling.

3.3 OLD VERSIONS OF SENATOR TERMINAL

3.3.1 Handset No 16

Handset 16B was used on Teles 8550, 8551 and 8553. This is distinguishable from the Handset 16A by its 'pepper pot' earpiece and a small recess under the earpiece.

Facility handsets were available for use on Teles 8520, 8521 and 8530 only.

Handset 16C - amplified handset with volume control at rear of earpiece.

Handset 16E - locking/non-locking on-off switch - used as a transmitter cut-off.

A small number of early installations of Senator were provided with Handsets 16D by using an Extension Bell Adaptor.

Part 4 COMMISSIONING PROCEDURES

The system should not be commissioned until all the cables have been terminated in the CCU and at every extension.

Fit the lid to the CCU and connect the mains supply to the unit.

The system is now running and ready for service.

Each extension should be tested as follows:

- With the handset in place on the telephone. Press and hold down the HOLD button. All the red 'Exchange Line' LEDs should light to indicate that the extension will ring for incoming calls on every line. The LEDs will not light if the data pair is reversed.
- Pick up the handset and listen for system dial tone, a continuous two-tone sound.
- Test the keypad by keying the extension's own number and listening for the engaged tone.
- Check the operation of the tone caller in the telephone by obtaining a ring back.
- Check exchange line access by obtaining dial tone (or the PBX operator) on each working line.

Part 4 COMMISSIONING PROCEDURES

Part 5 FACILITIES AND OPERATING PROCEDURES

Contents	Page
5.1 TONES	5.3
5.2 EXCHANGE LINE SERVICE	5.3
5.2.1 Outgoing calls	5.3
5.2.2 Incoming calls	5.3
5.2.3 Programming exchange line ringing	5.4
5.3 HOLD	5.4
5.4 TRANSFER	5.4
5.5 DIVERT	5.5
5.5.1 To program 'Divert'	5.5
5.5.2 To nominate extensions 1 to 5	5.5
5.5.3 To nominate extensions 6 to 10	5.5
5.5.4 While in 'Divert'	5.6
5.6 EXCHANGE LINE CONFERENCE CALLS	5.6
5.7 TEN ADDRESS REPERTORY DIALLING	5.6
5.7.1 To store a number	5.7
5.7.2 To send a stored number	5.7
5.7.3 To erase a stored number	5.7
5.7.4 To change a stored number	5.7
5.8 REPETITION OF LAST NUMBER KEYED	5.7
5.8.1 To repeat the last number called	5.7
5.9 INTERCOM CALLS	5.8

Part 5 FACILITIES AND OPERATING PROCEDURES

Part 5 FACILITIES AND OPERATING PROCEDURES

5.1 TONES

The system generates its own tones which are used on internal calls. These are:

- Ring Tone (RT). This is a 440 Hz tone with a regular 0.786 secs ON, 2.36 secs OFF cadence.
- Ringing. On internal calls the tone callers are operated to the same cadence as system ring tone. On incoming exchange calls the tone callers operate to exchange ringing cadence.
- Engaged Tone (ET). This is a 440 Hz tone with a regular 0.131 secs ON, 0.131 secs OFF cadence.
- Number Unobtainable (NU). This is continuous 440 Hz tone.
- Dial Tone (DT). This is a continuous 440 Hz + 350 Hz tone.
- 'Pip' or 'Click' Tone. If all the extensions programmed to be rung by an incoming call on an exchange line are busy or in 'Divert' then 'Pip' or 'Click' Tone will be connected to the intercom circuits to indicate an incoming call. A single 'Pip' of tone is repeated at approximately 1 second intervals.

5.2 EXCHANGE LINE SERVICE

An exchange line that is engaged will be indicated by the LED associated with the line button either:

- Glowing steadily, indicating a call in progress.
- Flashing at ringing cadence, indicating in incoming call.
- Flashing at the 'Hold' cadence to indicate a 'Call Held' condition.

5.2.1 Outgoing calls

An extension can make an exchange line call on any line which is free. On lifting the handset, system dial tone will be heard if there is a free intercom circuit. When the button associated with a free exchange line is depressed the caller is connected to the exchange line and the exchange dial tone is received. The required number can then be keyed in the normal manner.

5.2.2 Incoming calls

An incoming exchange call is signalled by the relevant exchange line LED flashing to exchange ringing cadence at each extension. Also, the tone caller at any extension that is programmed to ring for that line will sound at exchange ringing cadence, provided the extension is not 'off-hook' or in 'Divert'. If all extensions that are programmed to be rung on that line are either engaged or in divert a 'pip' or 'click' tone is connected to the intercom circuits.

Any extension can answer an incoming call by lifting the handset and depressing the relevant exchange line button. When the call is answered the exchange line LED will revert to a steady glow.

Part 5 FACILITIES AND OPERATING PROCEDURES

5.2.3 Programming exchange line ringing

Normally the tone callers at every extension will sound for all incoming calls but each extension user may individually decide which exchange lines will 'ring' their telephone. The extension user may check or alter the programmed arrangements as follows:

- Leave the handset 'on-hook'.
- Press and maintain the HOLD button.
- The exchange line LEDs indicate the state of ringing for each line. If the LED glows the telephone is programmed to 'ring' for the line. If the LED does not glow the telephone will not 'ring' to an incoming call on that line.
- Operating an exchange line button while the handset is 'on-hook' and with the HOLD button depressed will reverse the state of ringing on that line. If the exchange line LED is not glowing after the button has been pressed then the instruction to ring has been cancelled. If the LED glows after the button has been pressed then that line will ring at the extension.
- Release the HOLD button.

5.3 HOLD

Exchange Line calls may be held by pressing the HOLD button. When the HOLD button is pressed the telephone is disconnected from the exchange line which is held by the CCU. The exchange line LED flashes at the 'HOLD' cadence at all extensions. The extension user may make an intercom call or a call on another exchange line. At the completion of this call the extension user may return to the 'Held' exchange line by repressing that exchange line button.

If an extension puts an exchange line into HOLD and subsequently replaces the handset, then that extension will be given a short ring every 16 seconds as a reminder that the exchange line has been held. The extension will not be rung whilst it is dealing with other calls.

5.4 TRANSFER

Both incoming and outgoing exchange line calls may be transferred to other extensions on the system.

The exchange line call is held as described above and an intercom call is set up to the extension to which the call is to be transferred.

When the receiving extension answers and agrees to take the call, the transferring extensions should replace the handset on the telephone and the call will then be automatically transferred.

If the receiving extension does not answer, or does not wish to take the call, the transferring extension may speak to the exchange line call again by pressing the appropriate exchange line button. Alternatively another extension on the system may be called after pressing the telephone gravity switch to clear the first intercom call.

Part 5 FACILITIES AND OPERATING PROCEDURES

If required, the 'Divert' facility may be cancelled by programming the extension's own number using the above procedures.

5.5.4 While in 'Divert'

- The diverting extension can make outgoing exchange or intercom calls but all incoming calls are signalled at the nominated extension.
- A green 'Calls Diverted' lamp (LED) beside the DIVERT button glows on the diverting telephone and a green, 'divertee' lamp on the nominated extension telephone glows. (See Fig 3.1.)
- The nominated extension can call the diverting extension on intercom. The diverting extension only receives a single tone whether he is 'on-hook' or engaged on another call. If the diverting extension is 'on-hook' the green message waiting lamp (LED) will glow until the call is answered. This informs the diverting extension that the nominated extension has called.
- Transfer of a held exchange line call to the diverting extension can only take place if the diverting extension presses the appropriate exchange line button.

5.6 EXCHANGE LINE CONFERENCE CALLS

A 'conference' call can be set up between one exchange line and two extensions so that all three parties can speak to each other. Extensions connected via IPBX or External Extension adaptors cannot use this facility.

An extension must make or receive an exchange line call before a conference call can be set up by using the following procedure:

- Put the exchange line into HOLD and call the extension which is to join the conference call.
- When the extension answers he indicates his willingness to join the conference by pressing his HOLD button. This causes the green 'Divertee' LED at both extensions to flash rapidly.
- Push the HOLD button. This sets up the conference call and the LEDs stop flashing.

Once a conference call has been set up neither of the extensions can use the HOLD facility.

Either of the extensions, irrespective of which of them originally set up the call, can leave the conference by replacing the handset, allowing the other two parties to continue as with a normal call. Once this has happened the extension which is still connected to the exchange line can Hold or Transfer the call, or set up another conference call by repeating the above procedure.

5.7 TEN ADDRESS REPERTORY DIALLING

Teles 8560 and 8561 have a ten address repertory dialling as standard. This facility is also available on Teles 8521, 8551 and 8553. Up to 10 exchange line numbers of up to 18 digits each can be stored, one under each button from 1 to 0 of the push button dial unit. There is also the facility to repeat automatically the last number keyed.

Part 5 FACILITIES AND OPERATING PROCEDURES

The procedure for storing and sending a number is described below, and is also applicable for Tele 8553. For Teles 8551 and 8521 refer to the relevant User Guide.

- 5.7.1 To store a number**
- Lift the handset
 - Depress and release button P.
 - Depress and release the digit button under which the number is to be stored.
 - 'Key in' the number to be stored.
 - Replace the handset.

Numbers containing up to 18 digits can be stored so most international numbers can be accommodated.

- 5.7.2 To send a stored number**
- Lift the handset and depress an exchange line button to seize a free exchange line.
 - On receipt of exchange dial tone depress and release button T.
 - Depress and release the digit button under which the required number is stored.
- 5.7.3 To erase a stored number**
- Lift the handset
 - Depress and release button P.
 - Depress and release the digit button under which the number to be erased is stored.
 - Replace the handset.

- 5.7.4 To change a stored number**
- It is not necessary to erase a stored number before replacing it with a new number. Keying a new number into the store under a digit button already used replaces the previous number in that store.

- 5.8 REPETITION OF LAST NUMBER KEYED**
- The last exchange number called by keying in full is stored in the telephone until another exchange number is called. Exchange calls using repertory dialling will not affect the stored number, but intercom calls will be stored.

- 5.8.1 To repeat the last number called:**
- Lift the handset and listen for system dial tone.
- Select an exchange line by pressing the appropriate exchange line button and listen for dial tone.
- Press T twice.

Part 5 FACILITIES AND OPERATING PROCEDURES

5.9 INTERCOM CALLS

Any extension on the system may make an intercom call to any other extension by lifting the handset and on receipt of DIAL TONE, keying the required extension number. If the called extension is free the telephone will be rung and the calling extension will receive ring tone. When the called extension lifts the handset the intercom call is established. If the called extension is not connected to the system N.U. tone will be received.

When an extension user encounters engaged tone for another extension, he can either clear down and try again later, or use the 'camp on busy' facility by continuing to hold the connection. As soon as the other extension becomes free it will be called, and the engaged tone will change to ringing tone allowing the call to proceed normally.

Part 6 POWER FAIL ARRANGEMENTS

No provision is made for standby power to maintain the operation of the system if the mains power supply fails.

The relays in the CCU which normally perform the switching of the extension and exchange lines are arranged such that when the power fails, each exchange line is directly connected to certain extensions as follows (see diagram overleaf).

Line 1 connects to extn. 1 and 6

Line 2 connects to extn. 2 and 7

Line 3 connects to extn. 3 and 8

Line 4 connects to extn. 4 and 9

Line 5 connects to extn. 5 and 10

Each extension will be able to make or receive calls on the exchange line connected to it. The tone caller will operate to an incoming call but an extension bell connected via a Bell Adaptor will not operate. When two extensions are connected to one exchange line, bell-tinkle will be experienced at one telephone when the other dials.

Intercom calls cannot be made during mains failure, nor can calls be transferred. Any programmed facility e.g. 'Divert' or 'Exchange Line Ringing' will be cancelled and will need to be reprogrammed when power is restored. There will be no visual indication (LEDs) during mains failure.

Short term power disconnections (between 100 milliseconds and 2 seconds) may cause partial loss of customer-programmed facilities: these may be corrected by turning the power off for 5 to 6 seconds to allow the microprocessor to reset fully. When the power is restored the facilities should be reprogrammed and checked.

Where external extensions are fitted, the adaptor will be reset to the remote answer condition (lamp on).

Part 6 POWER FAIL ARRANGEMENTS

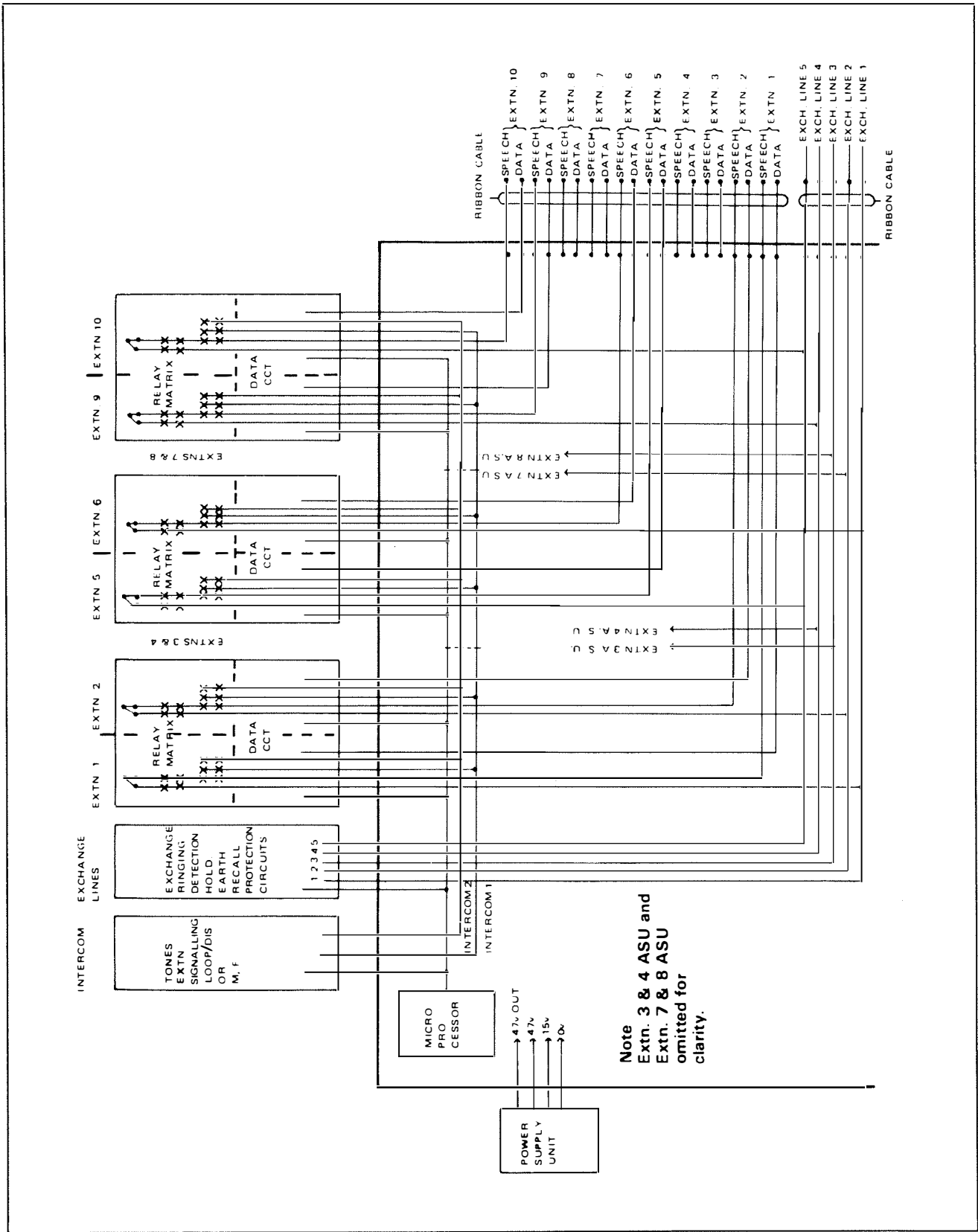

Fig 6.1 BLOCK SCHEMATIC (Part) SHOWING MAINS FAIL PATHS

Part 7 MAINTENANCE

Contents		page
7.1	ON SITE MAINTENANCE	7.3
7.2	TEST CONDITIONS	7.3
7.3	FUNCTIONAL TESTING	7.4
7.4	FAULT DIAGNOSIS	7.4
7.5	POWER UNITS	7.6
7.6	ASU CHANGEOUT	7.6
7.7	BACKPLANE	7.6
7.8	MAINTENANCE EXCHANGE	7.7
7.9	SYSTEM REPLACEMENT	7.7

Part 7 MAINTENANCE

Part 7 MAINTENANCE

7.1 ON SITE MAINTENANCE

In order to restore customer service as quickly as possible, a policy of changing out faulty apparatus should be adopted. On site repair of faulty items should be limited to the replacement of parts shown in the Parts List (page 9.1).

To provide all the spares required for faulting the CCU, a Maintenance Kit should be made up locally. It should consist of the following items.

- One Power Unit
- One Exchange Line ASU
- One Extension Interface ASU
- One Modified Extension Interface ASU for use with the IPBX Adaptor
- One Intercom ASU (LD or MF as appropriate)
- One Microprocessor Backplane
- One SENATOR terminal
- Spare power fuses
- One Adaptor SA 10253
- One Adaptor SA 10254
- One Adaptor SA 10255

The item codes and descriptions of these items are given in Section 9. A suitable carrying case for the Maintenance Kit is available (Case 265A). N.B. Case 265A will not hold a Power Unit.

On site maintenance of SENATOR systems is by functional testing, logic diagnosis, ASU changeout or system replacement.

NOTE

The mains power supply to the Senator System must be switched off before the Power Unit or an ASU is removed or replaced.

7.2 TEST CONDITIONS

The exchange lines test normal DEL conditions but will test 'low loop' if a megger test is used.

When testing within the system from a SENATOR telephone towards the CCU both the speech pair and data pair test approx. 45v d.c. The speech and data pair must not be allowed to come into contact, nor should the data pair be reversed.

Each time a system is powered up, the CCU determines which extensions are spare by testing if a telephone is connected or not. Only those extensions which have a telephone connected are regarded as working extensions, and are 'switched on'. Number Unobtainable tone is returned to an extension which calls a spare extension.

When a telephone is plugged in to a previously spare extension, that extension will be automatically 'switched on' by the CCU, and will work normally. If the telephone is subsequently removed, the extension will remain 'switched on' until the system undergoes another powering up sequence.

Part 7 MAINTENANCE

Spare extensions are connected to the park feed highway and will test approximately 45v d.c. provided the extension interface ASU is fitted, otherwise they will test 'dis'.

7.3 FUNCTIONAL TESTING

SENATOR offers a basic range of facilities which should be readily understood by the customer, leading to few misoperation faults. The customer should have copies of the Senator Extension User's Handbook.

Problems may occur if the mains supply is interrupted as this will cause partial or complete loss of customer-programmed facilities. When a customer reports the loss, either partial or complete, of customer-programmed facilities he should be asked to:

- Turn off the mains power for 5 to 6 seconds.
- When power is restored, reprogram the required facilities.
- Retest the facility(ies).

Many maintenance visits may be avoided by adopting this procedure. A description of the facilities is given elsewhere in this book and instruction handbooks (as described above) are supplied for the customer's use.

7.4 FAULT DIAGNOSIS

The faulting flow chart (Fig 7.1) will cover most anticipated faults, but may not be complete, nor may it cover obscure or multiple faults.

Before suspecting any of the units within the CCU ensure that the fault reported is not due to customer misoperation and that all extensions are plugged in and all cabling is undamaged. The data pair to extension telephones is polarity conscious, and if reversed or disconnected will:

- Prevent LED indicators from lighting.
- Result in no system dial tone.
- Render facility buttons inoperative.

Part 7 MAINTENANCE

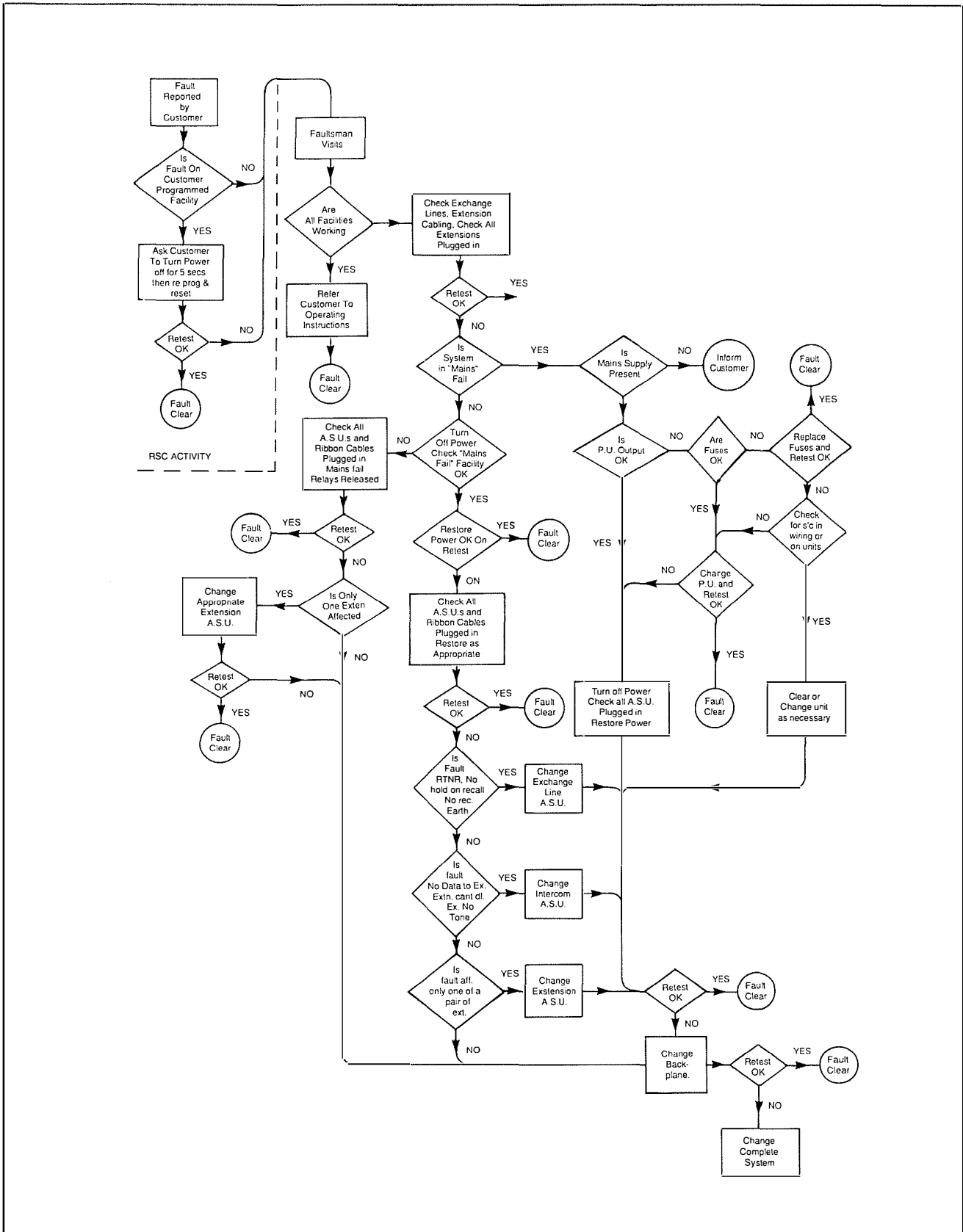

Fig 7.1 FAULTING FLOW CHART

Part 7 MAINTENANCE

7.5 POWER UNITS

Power unit outputs may be checked by carefully inserting meter test probes into the back of the power unit - backplane plug. The voltages should be checked with a Meter Multirange 12, Meter Multifunction 1A or suitable equivalent.

Voltages should be within the following limits:

- Testing between pin 4 and pin 1 - 44.7 Volts to 49.3 Volts
- Testing between pin 4 and pin 2 - 44.7 Volts to 49.3 Volts
- Testing between pin 4 and pin 3 - 14.5 Volts to 17.0 Volts

N.B. pin 1 output is via fuse FS3, all testing to be done with the negative probe on pin 4.

The power unit fuses are mounted in quarter-turn bayonet holders and spare fuses are held in the cover plate below the P.S.U.

The fuses are:

- Fuse FS 1 (mains input fuse) - fuse 72/2
- Fuse FS 2 (low voltage output) - fuse 73/4
- Fuse FS 3 (47v external output) - fuse 72/0.5

7.6 ASU CHANGEOUT

Before removing or replacing a Senator ASU the power supply must be switched off. Precautions must be taken to prevent damage to an ASU by electrostatic discharge.

The three types of ASUs are not interchangeable and the backplane sockets are offset to prevent them being plugged into the wrong position. Early versions of the ASUs had grey handles, but later versions have colour coded handles as follows:

Extension ASU	Yellow handle
Modified Extension ASU (for inter PBX adaptor)	Orange handle
Exchange Line ASU	Blue handle
Loop disconnect Intercom ASU	Off White handle
Multi Frequency Intercom ASU	Grey handle

Extension ASUs may be interchanged within the system to prove faults.

Excessive handling of ASUs should be avoided to prevent damage. They should be held by the edges in much the same way as a long playing record.

7.7 BACKPLANE

The backplane contains the system microprocessor and should this fail the entire system is likely to malfunction. The microprocessor controls the mains fail relays, so if a system stays in mains fail, even though the power supply outputs are testing correctly, a backplane fault should be assumed.

Part 7 MAINTENANCE

7.8 MAINTENANCE EXCHANGE

BT gives the customer a 12 month warranty and faulty items found within this period should be replaced free of charge. Whenever a module has been maintenance exchanged, the replacement item becomes the customer's property and the faulty item returns to BT

The District store will 'maintenance exchange' the faulty item, which where possible, should be securely packed before being handed to the storeman. Fault labels A8807A should be attached to every unit and completed in full.

Correctly completed fault labels will help to identify quickly any weakness in design or production. If large numbers of items are returned for repair, but faults are not apparent when they are tested, then analysis of the fault labels may lead to design faults being detected.

7.9 SYSTEM REPLACEMENT

Systems replacement should be regarded as the last resort. It is not foreseen that a fault condition will arise to cause all units to fail.

Senator systems are sold outright and so faulty systems may only be recovered when they have been replaced complete. The Central Control Unit must never be transported with the power unit in position as this may strain the mounting lugs and so cause damage.

Part 7 MAINTENANCE

Part 8 HOW IT WORKS

The system employs normal signalling to the exchange (either public exchange or PBX). Each SENATOR telephone has a keypad which can be either loop-disconnect pulsing (LD), or multi-frequency ac signalling (MF) to suit the type of exchange working. There is no transmission bridge connected into the circuit at the CCU on exchange line calls. The extension is directly connected through to the exchange on exchange line calls.

The telephones are connected to the CCU by 4-wire connections which are arranged as speech and data pairs. Signals from the keypad and speech signals in the usual form of 'varying current' use the speech pair. All other signals use the data pair, and are in the form of coded - 3V pulses superimposed on a standing 50V supply from the CCU power unit.

Briefly, the microprocessor in the CCU continuously monitors the state of incoming exchange lines and the data pairs from the SENATOR telephones. The microprocessors in the telephones monitor the incoming data pairs from the CCU and the state of the gravity switch springs and the 'function' buttons. Any change in the state of these is detected, causing an interchange of information within the system, which is used to process the call.

The mains driven power unit within the CCU supplies:

- All power required by the CCU.
- Power to the microprocessor, LEDs and tone caller at each telephone, this power being fed to the telephone over the data pair.
- Power for the speech circuit and keypad at each telephone on intercom calls, this power being fed to the telephone over the speech pair.

The power feed at each telephone contains a diode to protect the microprocessor circuitry against damage in the event of a reversal of the data pair. However under these circumstances a complete failure will result as there is no 'constant polarity' circuit provided.

The power circuit in the telephone contains a series regulator to control the voltage and a high impedance filter to block data signals from the power supply. All power supplies are generated by constant current circuits to prevent fluctuations in the dc supply caused by the operation of the LEDs or tone caller being detected as false data signals.

The system is designed to provide for up to 5 + 10 size installation. Although the system sizes may differ the microprocessors in all CCUs are programmed on the assumption that all systems have 10 extensions. Where there are fewer than 10, 'padding routines' are included in the programme to replace the 'missing' extensions, so keeping the operating cycle of the microprocessor the same in all systems. The 'padding routines' are added or taken away automatically within the microprocessor as extensions are recovered or provided.

The CCU generates two tones, one of 350 Hz and one of 440 Hz which are used to provide all the tones required by the system. The CCU also controls the signals which are used to light the LEDs and operate the tone callers.

Part 8 HOW IT WORKS

Part 9 PARTS LIST OF CURRENT EQUIPMENT FOR SENATOR

DESCRIPTION	ITEM	ITEM CODE
CCU Housing, including Termination Board	Equipment SA 10256	37 4217
Kit consisting of Equipment SA 10256 Senator Backplane No. 2 1 Senator ASU DPA 1207A 3 Senator ASU DPA 1209A 1 Senator Power Supply Module D141065A	Senator Kit No. 2	37 4639
Microprocessor Backplane	Senator Backplane No. 2	37 4640
Power Supply Circuit Board	Senator Circuit Board DPA 1212A	37 4219
Power Supply Module	Senator Power Module D141065A	37 4220
Extension Line ASU	Senator ASU DPA 1209A	37 4221
LD Intercom ASU	Senator ASU DPA 1210A	37 4222
MF Intercom ASU	Senator ASU DPA 1217A	37 4223
Exchange Line ASU (5 lines)	Senator ASU DPA 1207A	37 4224
External Extension Adaptor	Senator Adaptor SA 10253	410972
LJU Bell Adaptor	Extension Bell Adaptor	870216
Extension Bell Adaptor	Senator Adaptor SA 10255	410974
IPBX Facility	Senator Adaptor SA 10254 + Modified Extension Card	37 4225
LD/MF Basic Terminal (light grey)	Senator Telephone 8560 A or B	870285
LD/MFLST Terminal (dark grey)	Senator Telephone 8561 A or B	870284
Fuse FS1	Fuse 72/2	31 4209
Fuse FS2	Fuse 73/4	31 4004
Fuse FS3	Fuse 72/0.5	31 4216

**Part 9 PARTS LIST OF CURRENT
EQUIPMENT FOR SENATOR**

Part 10 AUXILIARY EQUIPMENT

Contents	Page
10.1	10.3
10.1.1	10.4
10.1.2	10.6
10.1.3	10.6
10.2	10.8
10.2.1	10.10
10.2.2	10.13
10.2.3	10.13
10.2.4	10.13
10.2.5	10.14
10.2.6	10.14
10.2.7	10.14
10.2.8	10.14
10.3	10.15
10.3.1	10.15
10.3.2	10.18
10.3.3	10.18
10.3.4	10.18
10.3.5	10.18
10.3.6	10.18
10.3.7	10.19
10.3.8	10.19
10.3.9	10.19
10.3.10	10.19
10.3.11	10.19
	10.20

Part 10 AUXILIARY EQUIPMENT

Part 10 AUXILIARY EQUIPMENT

10.1 EXTENSION BELLS

If an extension bell is required at an extension, an Extension Bell Adaptor is required capable of ringing ONE high impedance extension bell only.

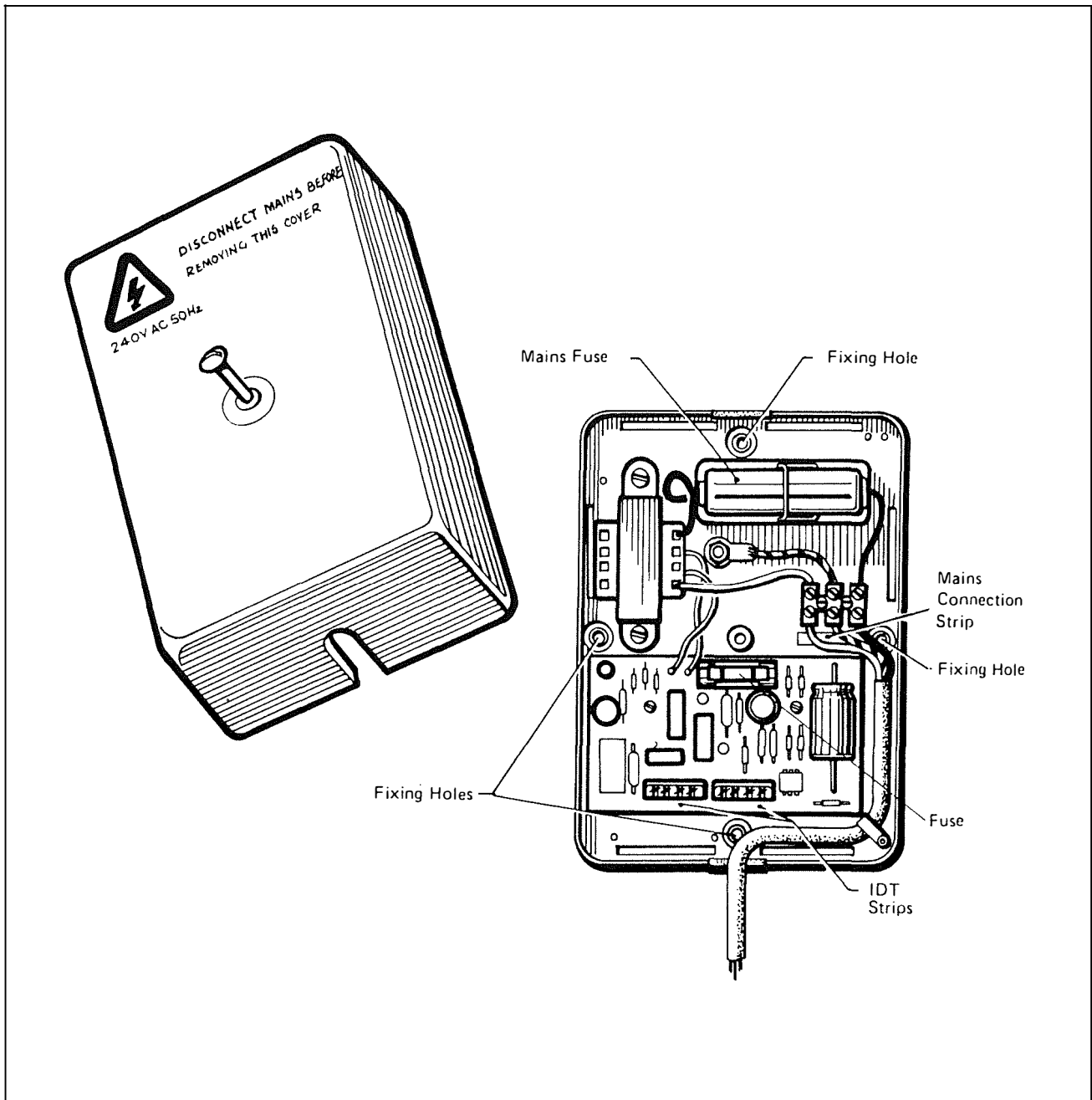

Fig 10.1 EXTENSION BELL ADAPTOR SA 10255

When an Adaptor is fitted to an extension, all incoming calls to that telephone will be signalled by the tone-caller in the telephone as well as by the extension bell. Two types of Extension Bell Adaptor can be used on the Serator: (1) Extension Bell Adaptor SA10255; or (2) LJU Bell Adaptor. The LJU Bell Adaptor supersedes the Bell Adaptor SA10255.

Part 10 AUXILIARY EQUIPMENT

10.1.1 Installation details for extension bell adaptor SA10255

The Extension Bell Adaptor should be fitted as close to the extension telephone as possible, but bearing in mind that the Adaptor is mains powered and must be positioned close to a suitable socket outlet.

The cable to the extension from the CCU must be terminated on the Adaptor, and a 6-wire cable, Cable Equipment 2503F, should then be run to the telephone socket. The extension bell may be wired to the Adaptor or to the telephone socket as convenient (see wiring diagram overleaf).

NOTE

If the extension telephone has a 4-wire line cord, this should be changed to a 6-wire type Cord Conn. 6/500. Inside the telephone, SW1 must be disconnected. The switch which is a 'safety pin' type as shown in the illustrations below, is located on the underside of the printed circuit board module which supports the facility buttons. Take care not to disturb any ribbon cable connections. SW1 is designated Link A on Teles 8520, 8521 and 8530 and is located in a different position. N.B. Teles 8560 and 8561 have been designed not to require this switch.

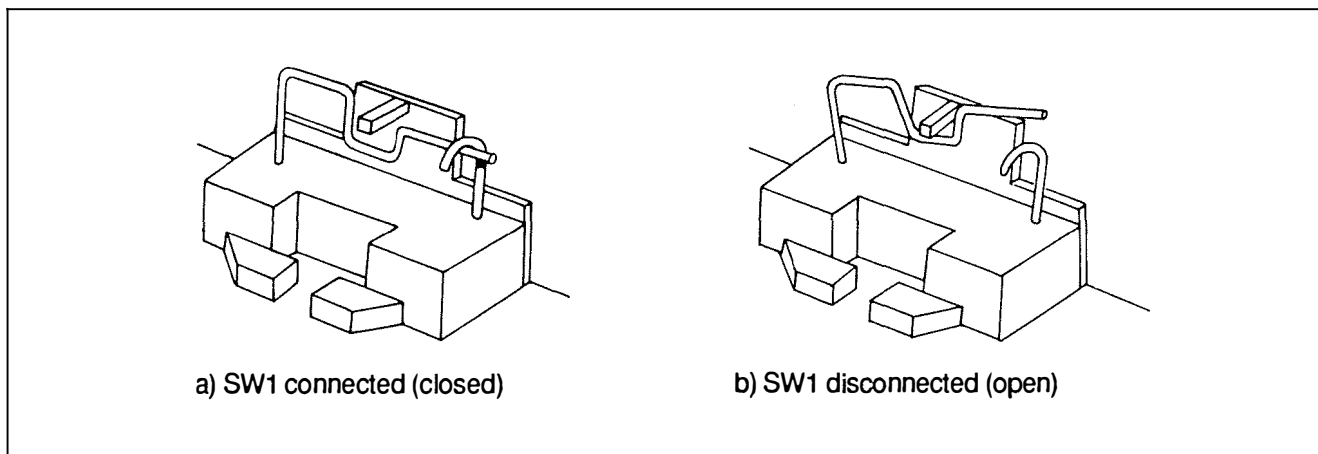

Fig 10.2 SWITCHES

Part 10 AUXILIARY EQUIPMENT

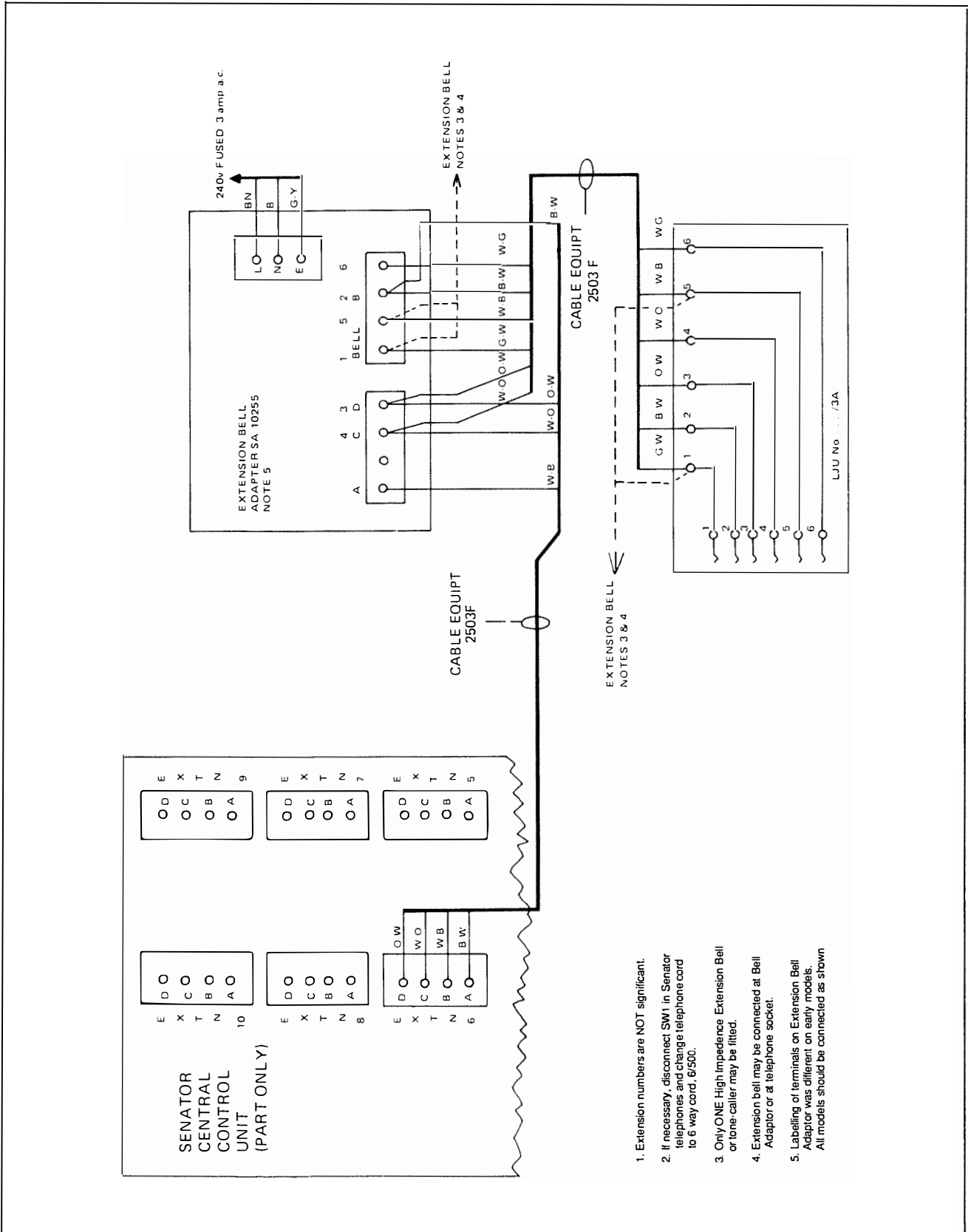

Fig 10.3 CONNECTION OF EXTENSION BELL ADAPTOR SA10255

Part 10 AUXILIARY EQUIPMENT

10.1.2 Maintenance of extension bell adaptor SA10255

Extension Bell Adaptor Units contain transistorised circuits mounted on printed circuit boards and are not suitable for repair in the field.

When a unit is proved to be faulty its fuses should be checked and changed if necessary, and if the unit is still faulty it should be replaced with a maintenance spare. The fuses used are as follows:

FS1 (Mains Fuse) 50 mA A/S Fuse 36A/0.05

FS2 (Output Fuse) 100 mA Q/B Fuse 73/0.1

Extension bell adaptor units may be tested in the following way:

- Disconnect the mains supply to the unit.
- Disconnect the wiring to the CCU, telephone and extension bell (if connected at the unit).
- Connect a high impedance bell across terminals JL1 and JL5.
- Connect short lengths of wire to terminals JL4 and JL6.
- Replace cover and reconnect mains supply.
- Connect a 1.5 v battery to the wires fitted above as follows:

+ ve to JL6
- ve to JL4

When the battery is connected, the relay in the unit should be heard to operate and the bell should ring to the 60v 25 Hz output.

All faulty units should be returned to the District store in the packing of the replacement unit, and should have a fault label A8807A attached giving the details of the fault.

10.1.3 Installation details for LJU bell adaptor

The LJU Bell Adaptor is fitted in place of the normal Senator LJU at those extensions that require an extension bell facility. The bell adaptor is wired to the CCU using 6-wire twisted pair cable (CE 2503F). Please refer to Note on page 10.4.

Fix the LJU Bell Adaptor in place of the standard LJU and connect the adaptor to the appropriate extension at the CCU. Connection details are shown in Fig 10.4. The W/O and G/W conductors are both terminated at the CCU onto the 'C' connection point. It is important that the 'O' volt and 'C' wire termination points at the LJU adaptor utilise separate wires for the connection to the CCU.

Connect a suitable bell or tone caller, using two wires, onto the connection points within the adaptor marked 'Bell'.

Part 10 AUXILIARY EQUIPMENT

10.2 EXTERNAL EXTENSIONS

When only two wires are available between the CCU and an extension, as is the case with external extensions, an External Extension Adaptor SA10253 is required. The adaptor converts the digital signalling on the data pair from the CCU, to conventional d.c. and 25 Hz. signalling over the speech pair to the telephone, and vice versa. An External Extension Adaptor allows approved standard telephones, and other equipment which do not use digital signalling, to be connected to a Senator system.

An illuminated press switch which controls the ringing of the bell in the telephone at the extension, is mounted in one corner of the unit as shown in the illustration. (This is used for incoming exchange line calls.)

Part 10 AUXILIARY EQUIPMENT

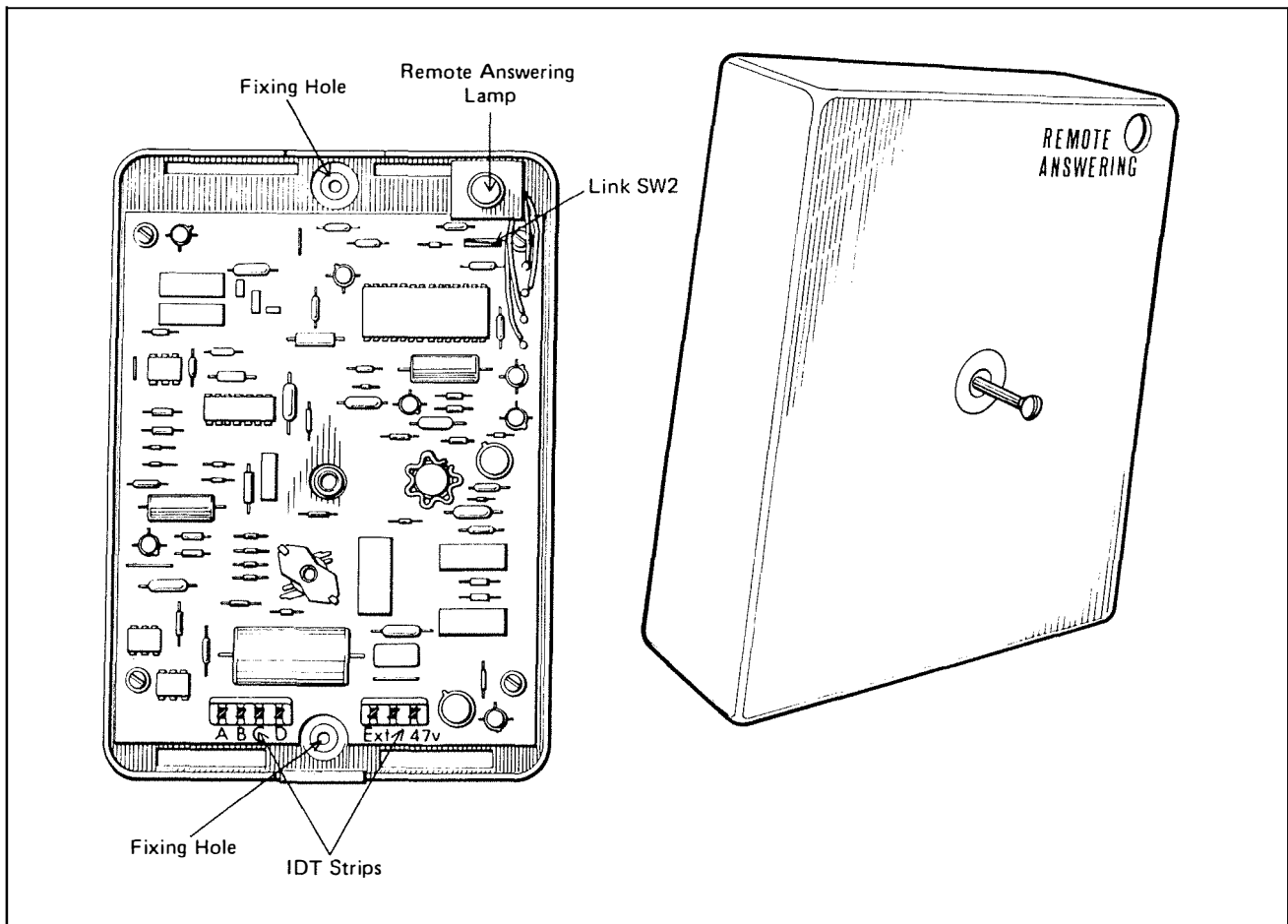

Fig 10.6 EXTERNAL EXTENSION ADAPTOR

Up to four 2-wire extensions can be provided on a Senator system.

The telephones fitted at the extensions will usually be standard instruments wired as '2-wire PBX extension with earth loop recall', e.g. Tele 8200R, but other approved 2-wire telephones equipped with an earth loop recall button may be used.

Only approved telephones detailed in lists 1, 2, 9 and 10 of the Department of Trade and Industry Telephone lists can be used.

The External Extension Adaptor is loop disconnect only. It is therefore recommended that dual signalling telephones are installed. These must be set on installation for loop disconnect signalling.

Extension bells may be fitted at an external extension in the same way as normal exchange lines, but no more than two high impedance bells can be rung by an External Extension Adaptor.

Maximum loop resistance from the adaptor to the telephone is 1250 ohms. On exchange line calls, CCU to exchange range must be included in this figure.

Part 10 AUXILIARY EQUIPMENT

10.2.1 Installation

The External Extension Adaptor should be fitted as close to the CCU as possible, but should be positioned such that the customer can both see and operate the illuminated press switch easily.

A 6-wire cable, Cable Equipment 2503F, should be run from the CCU to the Adaptor, and the connection from there to the telephone should be made using the appropriate 2-wire cable. The wiring to the telephone should terminate in a LJU -/1A, with a signalling earth provided locally.

Terminating details are given in the wiring diagram overleaf.

The Adaptor is powered by a + ve 47 volt supply which is obtained from the CCU. This supply appears on the strip of four connections mounted on the bottom left hand corner of the Line Termination Board (see Fig 2.5 on page 2.8). The W-G wire in the 6-wire cable should be terminated on the topmost available connector of the strip. No connection to the earth in the CCU is required.

A 'safety pin' type link, SW2, if fitted on the PCB of the Adaptor, close to where the wires to the illuminated press switch are terminated. This switch must be closed, as shown in Figure 10.2 on page 10.4.

When the Adaptor is connected to a private circuit which uses SS AC15C, a separate connection must be made from the 'C' terminal to the signalling earth terminal on the signalling unit. A 270 k ohm, 1/4 W resistor must be in series with this wire in order to suppress noise. The resistor must be fitted in a BT52A or equivalent, which should be positioned adjacent to the Adaptor. Refer to the wiring diagram (fig 10.7) for terminating details.

Part 10 AUXILIARY EQUIPMENT

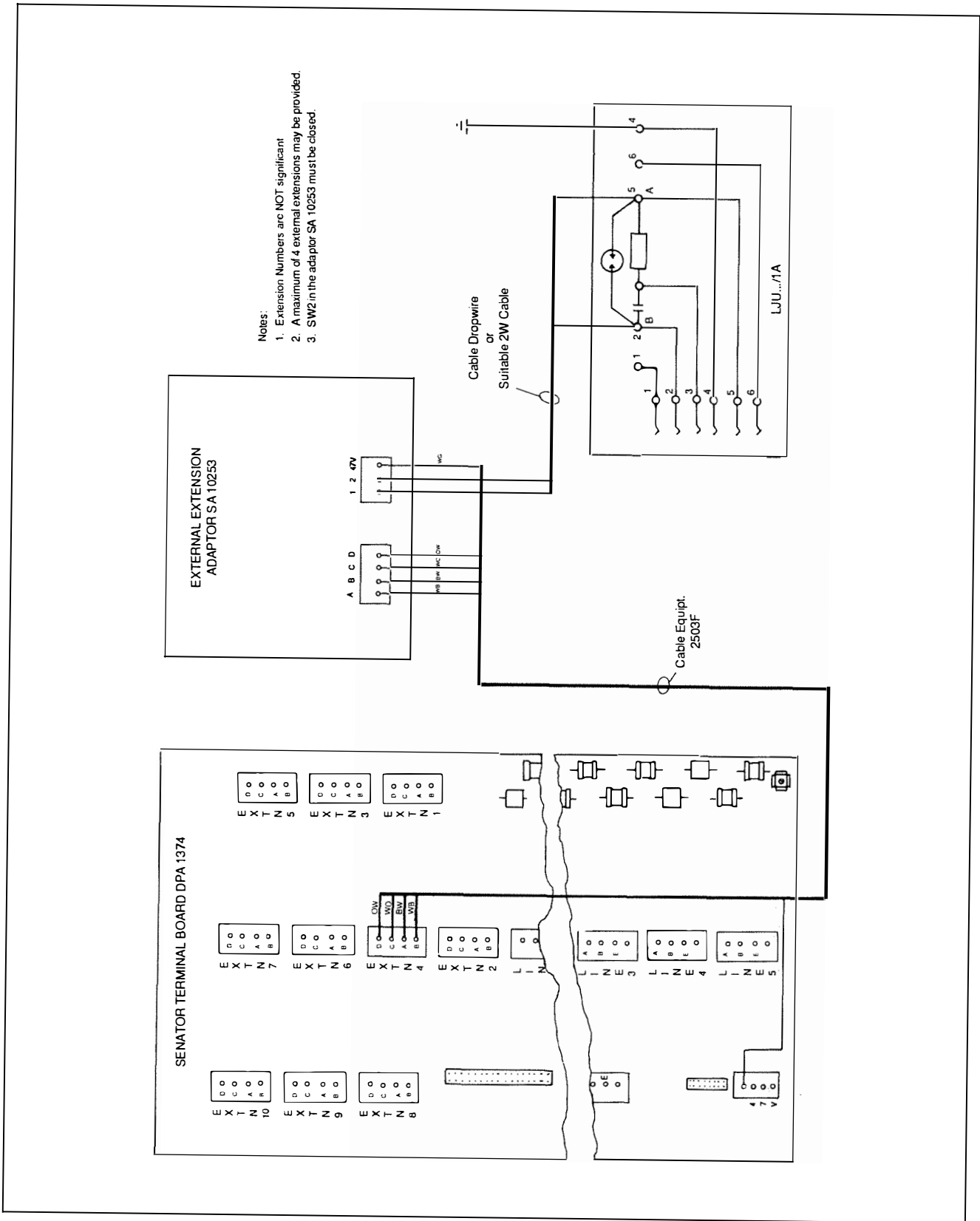

Fig 10.6 CONNECTION OF EXTERNAL EXTENSION ADAPTOR

Part 10 AUXILIARY EQUIPMENT

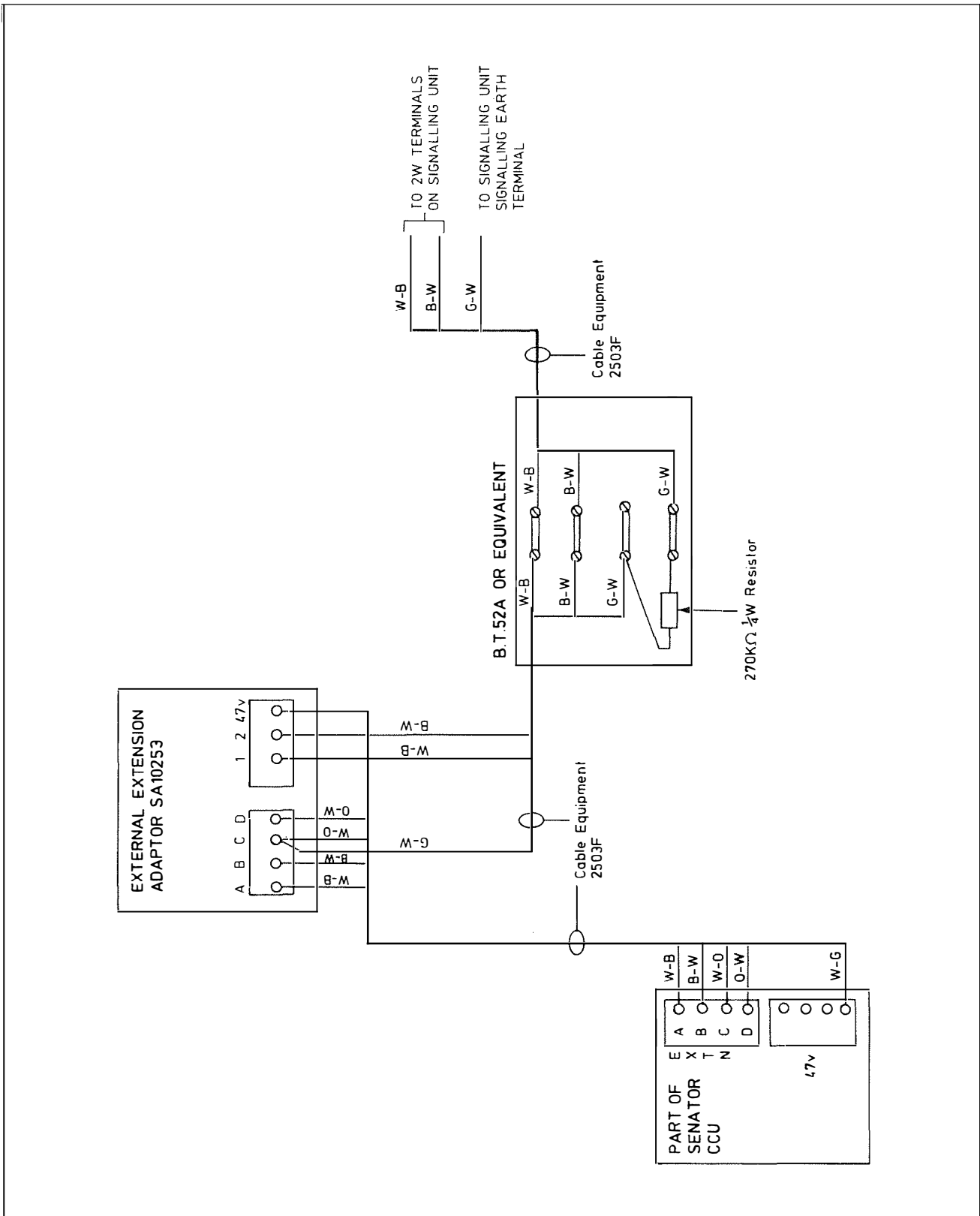

Fig 10.7 MODIFICATION TO SENATOR EXTERNAL EXTENSION ADAPTOR WHEN USED WITH SSAC15C SIGNALLING CONVERTERS

Part 10 AUXILIARY EQUIPMENT

10.2.2 Facilities and operating procedures

A telephone connected to an External Extension adaptor has access to most of the facilities available to a Senator telephone but some of the operating procedures are different.

System dial tone is not returned to an external extension when the handset is lifted.

10.2.3 Exchange line calls

The bell (or tone caller) in the telephone will **always sound to signal incoming intercom calls** but incoming exchange line calls can be programmed either to call at the extension or not. This facility is controlled in two ways:

- By the illuminated press switch mounted on the adaptor. When the switch is operated the lamp glows indicating that the bell at that extension will sound on receipt of an incoming exchange line call. A second operation of the switch will turn off the lamp and the bell will no longer sound. Subsequent operations of the switch will alternately turn the bell and lamp on and off.
- By dialling a code from that extension. To make the bell sound at the extension for incoming exchange line calls, the extension user must lift the handset and dial **41 on his own extension**. The bell may be 'turned off' by lifting the handset and dialling 40. In both cases the handset must be replaced before making any other calls.

Either of the two methods may be used to switch the bell on or off.

Calls may be answered by lifting the handset.

Outgoing exchange line calls can be made as follows:

- Lift the handset and dial 9. The first free exchange line will be connected to the extension, but if all the lines are busy no tone will be heard
or
Lift the handset and dial 8, followed by the digit (1,2,3,4 or 5) which corresponds to the exchange line required. If the line is engaged no tone will be heard.
- On receipt of exchange dial tone, dial the required number.

10.2.4 Hold

Exchange line calls may be held by pressing the RECALL button on the telephone.

An enquiry call can then be made to an extension by dialling 0 to obtain system dial tone, and then dialling the appropriate digit(s). An enquiry call may be made over another exchange line by first dialling 9 (or 8x) to obtain the exchange line, and then dialling the required number.

The procedure to return to the 'held' call depends on what type of enquiry call was made.

Part 10 AUXILIARY EQUIPMENT

If the enquiry call was to another Senator extension, that extension must first be allowed to clear down. The handset should then be replaced momentarily and the held call will be reconnected when the handset is lifted.

If the enquiry call was to an **exchange line**, pressing the RECALL button will reconnect the 'held' line, and hold the line to which the enquiry was made. You can alternate between the original caller and the third party by pressing the recall button as required this is known as 'Call Brokering'. Whilst using call brokering, no enquiry calls may be made unless one of the call exchange lines is first cleared down. Replacing the handset momentarily reconnects the held line, and releases the seized line.

All enquiry calls are secret from the held exchange line.

If the handset is replaced after a call has been held, the reminder ring back as described on page 5.4 will be obtained.

10.2.5 Transfer

An exchange line call can be transferred to another extension by holding the call and making an enquiry call to the required extension. When the extension answers and accepts the call, the call will be automatically transferred by the transferring extension replacing the handset.

An exchange line call which has previously been transferred to the external extension from another extension, cannot be transferred again, and enquiry calls cannot be made.

The HOLD and TRANSFER facilities are not available when the Senator is connected to a PBX which uses earth loop recall.

10.2.6 Intercom calls

Calls to other extensions can be made as follows:

- i Lift the handset and dial 0.
- ii When system dial tone is heard, dial the required extension number.
- iii
 - a) If the required extension is free, system ring tone will be heard.
 - b) If the required extension is busy, system engaged tone will be heard.
 - c) If the number of an unequipped extension is dialled, system number unobtainable tone will be heard.

Incoming calls can be answered by lifting the handset.

10.2.7 Divert

An extension connected to an External Extension Adaptor cannot divert incoming calls, but it may receive diverted calls from another extension.

10.2.8 Maintenance

Telephones connected to External Extensions Adaptors will have similar line conditions and testing characteristics to those of ordinary DELs.

The Adaptor Units contain integrated circuits mounted on printed circuit boards and are therefore not suitable for repair in the field. When a unit is suspected of being faulty it should be replaced with a maintenance spare to prove the fault.

Part 10 AUXILIARY EQUIPMENT

In order to prove whether a fault lies within the CCU or the Adaptor Unit, the wiring to the CCU should be disconnected from the Adaptor Unit and then connected to a Senator Telephone, via a LJU -/3A. The + 47v wire (W-G) should be insulated to avoid contacts during this operation. Testing from the Senator Telephone will prove whether the CCU is functioning correctly.

All faulty units should be returned to the District store, for forwarding to the DRC, in the packaging of the replacement unit, with a fault label A8807A attached giving the details of the fault.

10.3 INTER PBX CIRCUITS

Inter PBX circuits may be connected to the Senator in one of two ways:

- Onto an even numbered extension, using a Senator Inter PBX Adaptor SA10254.
- By connecting the private circuit in place of an exchange line.

10.3.1 Provision of inter PBX circuits using the adaptor

A Senator Inter PBX Adaptor SA10254, terminated on an even numbered extension circuit, is used as an interface between the CCU and the private circuit, as shown in figure 10.8. The adaptor converts the digital signalling on the extension circuits data pair to E and M signalling (SSDC5). The SSDC5 signalling may be sent directly to line, but it is more usually converted to SSAC15 or SSDC10 using signalling units 44B and 45A respectively. As the adaptor is wired in place of an extension, each adaptor used reduces the even extension capacity by one.

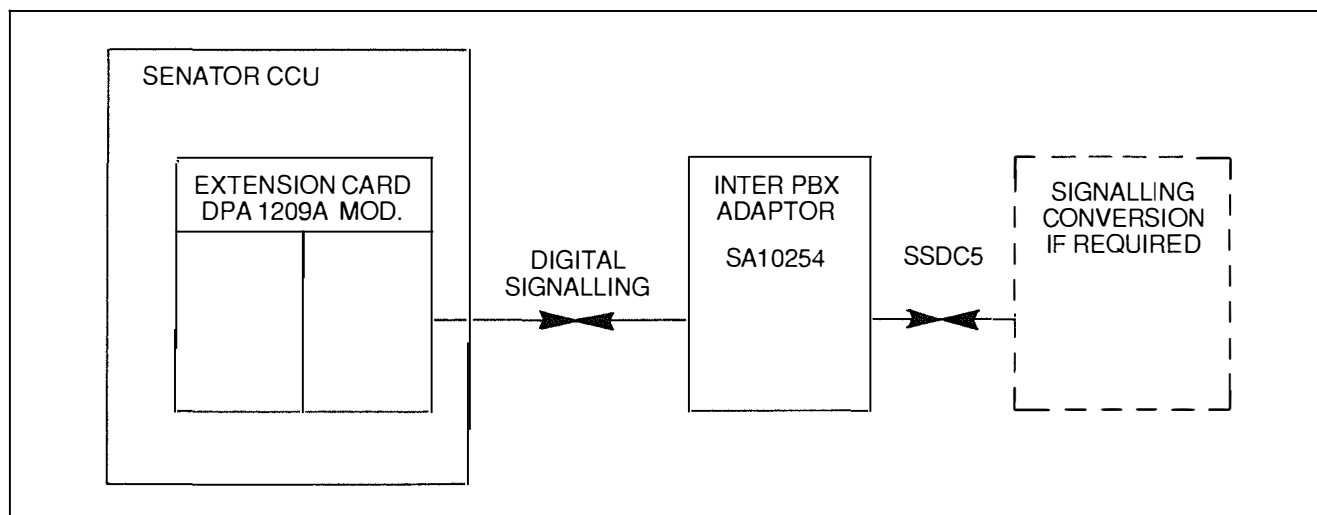

Fig 10.8 PROVISION OF INTER PBX CIRCUITS USING ADAPTOR SA10254

Packed with Inter PBX Adaptor is a modified extension line card DPA 1209A. The card has 10uF capacitors wired across the intercom feed resistors of the even circuit only. It is essential that these cards are used in conjunction with the Inter PBX Adaptors to minimise the transmission loss through the System. When an Inter PBX Circuit is recovered the modified card must be replaced by a standard card. The modified cards are identified by an orange handle on the card.

Part 10 AUXILIARY EQUIPMENT

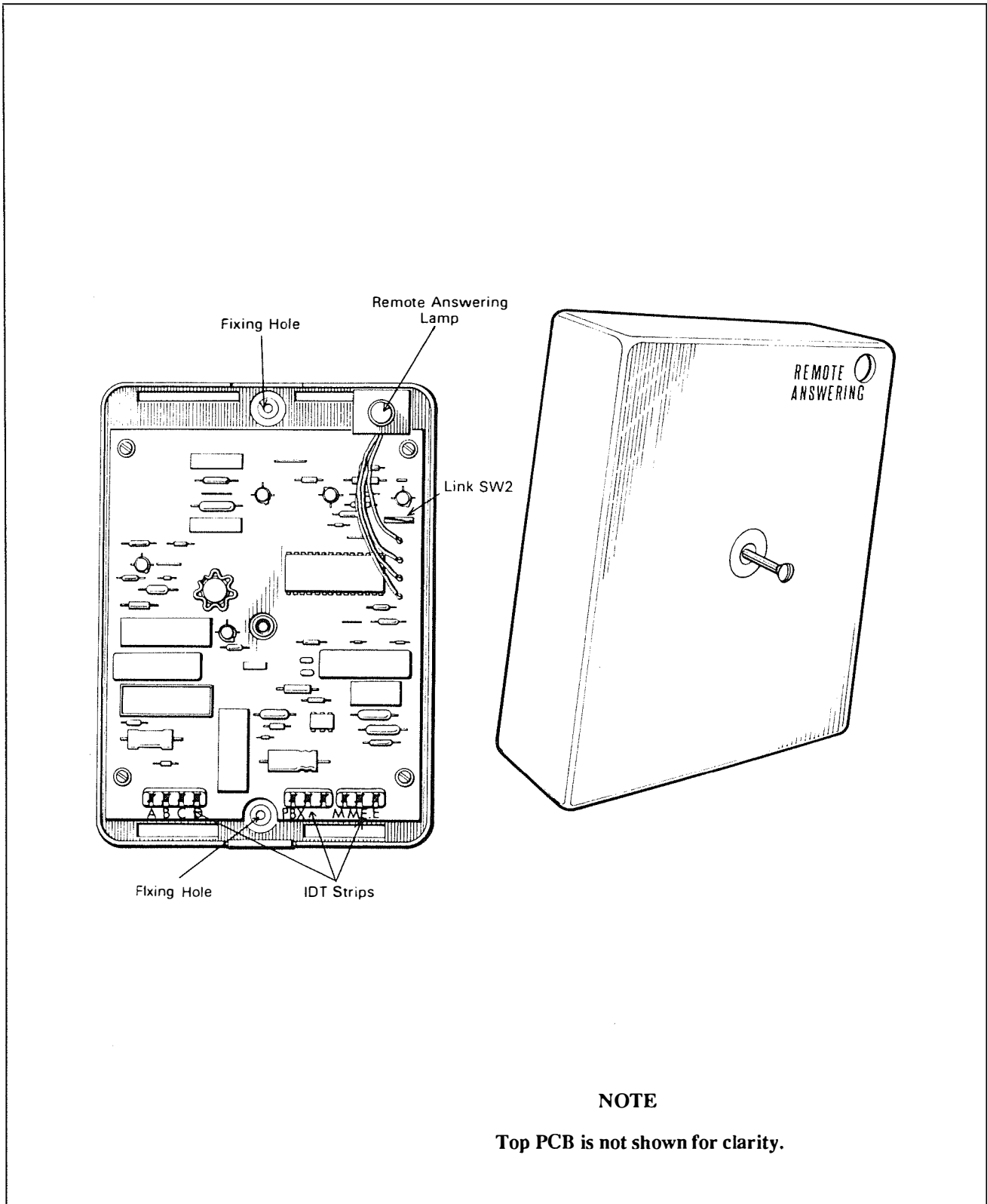

Fig 10.9 INTER-PBX ADAPTOR

Part 10 AUXILIARY EQUIPMENT

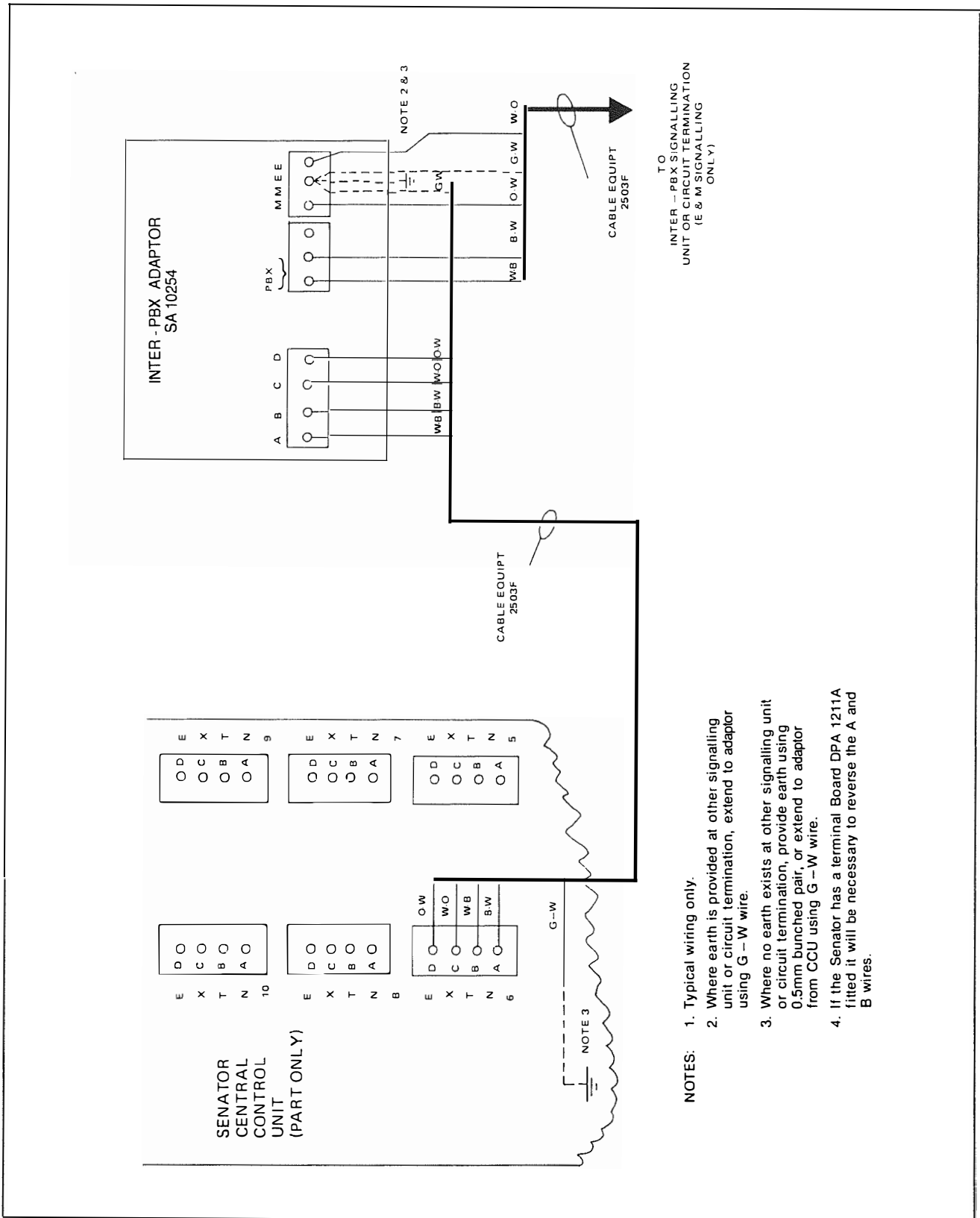

Fig 10.10 CONNECTION OF INTER-PBX ADAPTOR.

Part 10 AUXILIARY EQUIPMENT

- 10.3.2 Installation of Inter PBX adaptor**
- The Inter PBX adaptor should be fitted as close to the CCU as possible, but should be positioned so that the customer can both see and operate the illuminated press switch easily.
- A safety pin type link SW2 is fitted, on the adaptor PCB, close to where the wires to the illuminated press button switch are terminated (shown in Fig 10.9). This switch must be closed when used with Senator.
- 10.3.3 Facilities and operating procedures**
- The Inter-PABX circuit allows extensions connected to the PBX to make calls to, or receive calls from all the Senator extensions. The Hold, Transfer and Divert facilities are not available to the PBX extensions, but the PBX may be a 'nominated extension' when a Senator extension wishes to divert its calls.
- Incoming exchange line calls to the Senator system may be extended through to the PBX and answered there, but PBX users cannot make outgoing calls over those lines.
- 10.3.4 Incoming exchange line calls.**
- The illuminated press switch on the adaptor is used to control whether incoming exchange line calls to the Senator system are extended through to call at the PBX. When the switch is operated the lamp glows to indicate that exchange line calls will be extended. A second operation of the switch will turn off the lamp, and exchange line calls will then no longer be extended. Subsequent operations of the switch will alternatively switch the facility on and off.
- Exchange line calls which are extended from the Inter-PBX adaptor will only be answered at the PBX if it is configured to respond to the calling signal, for example, by an operator.
- 10.3.5 Intercom calls**
- Senator extensions call the PBX in the same way as they call other extensions by keying the number of the extension to which the Inter-PBX circuit is connected. Depending on the type of PBX, they will be either connected to the PBX operator, or be able to set up a call by keying the number of the extension they want.
- When the PBX operator or a PBX extension user is connected to the Senator system over the Inter-PBX circuit, they will hear Senator system dial tone in the same way as the user of a Senator extension would upon lifting the handset. If the number of the required extension is dialled the call will proceed in the normal way.
- 10.3.6 The timeout period**
- Once an IPBX adaptor responds to an intercom call, it starts a timer running. The timeout period can be either 30 or 60 seconds, depending on the adaptor's software level. If no Called Sub Answer signal is detected before the timer expires then the adaptor clears down the call.
- If an exchange line call is autotransferred over the IPBX adaptor the exchange line will be presented to the input of the adaptor. As an exchange line does not generate a forward clear signal, the timeout is required to overcome the possibility of the circuit locking up in the event of the call remaining unanswered.

Part 10 AUXILIARY EQUIPMENT

10.3.7 Cleardown before CSA

If the Senator is equipped with MK2 software and the extension clears down before the CSA signal is received, and provided no autotransfer of an exchange line has taken place, the adaptor is sent clear-down information from the CCU. This will release the adaptor which will clear-down the PBX link and become available for use immediately.

If the Senator is equipped with MK1 software no clear-down information will be sent from the CCU. The circuit will not become available for use, therefore, until the 30 or 60 second timeout has expired.

If an exchange line was autotransferred to the adaptor, the adaptor will continue to seize the exchange line until either the CSA signal, followed by the clear-down signal, is received from the PBX, or the timer expires.

10.3.8 Autotransfer before CSA.

If an exchange line is autotransferred before the CSA signal is received from the PBX and the CSA signal does not appear within the timeout period of the adaptor answering the original intercom call to it, then the exchange line will be released after this period. It is therefore inadvisable to autotransfer an exchange line to the PBX when there is still ringtone being generated by the PBX.

One must also be careful when the PBX is generating engaged tone etc. Once the adaptor has answered the calling extension's original intercom call, it is possible to autotransfer an exchange line. If it is autotransferred into PBX engaged tone, etc., then the PBX may never generate a CSA signal (hence the need for the timeout period).

10.3.9 Call priorities

If an IPBX adaptor has decided that it is being called on both intercom and exchange lines, then when the CSA signal is received from the PBX, it will answer the intercom call first.

10.3.10 Maintenance

The Inter-PBX Adaptor Unit uses Signalling System DC5 which is E and M signalling. The operation of the unit may be tested by monitoring the conditions on the E and M terminals.

The Adaptor Units contain integrated circuits mounted on printed circuit boards and are therefore not suitable for repair in the field. When a unit is suspected of being faulty it should be replaced with a maintenance spare to prove the fault.

The unit obtains power from the CCU over the data pair and no other power supply is used.

In order to prove whether a fault lies within the CCU or the Adaptor Unit, the wiring to the CCU should be disconnected from the Adaptor Unit and then connected to a Senator Telephone, via a LJU -/3A. Testing from the Senator Telephone will prove whether the CCU is functioning correctly.

All faulty units should be returned to the District store for forwarding to the DRC in the packaging of the replacement unit, complete with fault label A8807A giving the details of the fault.

Part 10 AUXILIARY EQUIPMENT

10.3.11 Provision of inter PBX circuits in place of exchange lines

Inter PBX circuits provided in this way must appear to the CCU to have the same signalling conditions as an exchange line, i.e. loop out, generator in. A relay set 1A1/SA10200 provides the correct interface, and may be used to send SSDC5 or SSDC10 to line. The SSDC5 will usually be converted to SSAC15 using signalling units 44B. A block diagram is shown in figure 10.11 below.

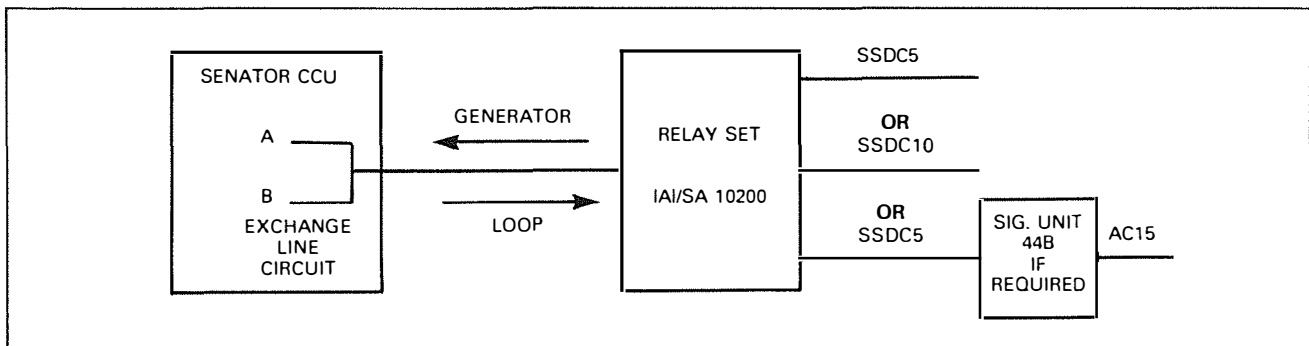

Fig 10.11 PROVISION OF INTER PBX CIRCUITS IN PLACE IN EXCHANGE LINES

The following diagram shows an alternative method of providing an Inter PBX circuit in place of an exchange line. The signalling unit 53A is connected to a **2-wire extension port** at the main PBX installation. Signalling unit wiring details are contained in application diagrams SA/SAW 103240 and SA/SAW 103250.

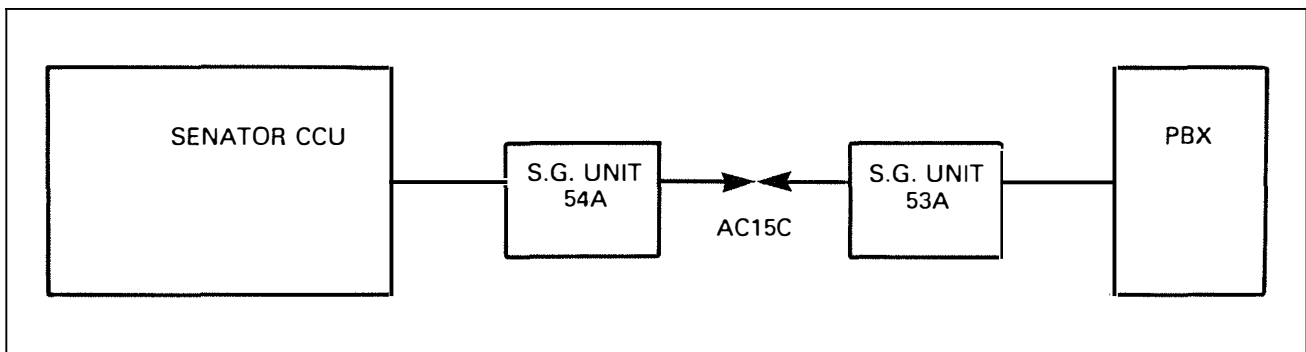

Fig 10.12

Part 11 DOCUMENTATION

The documentation published for the Senator is:

Senator User Guide CPE/MS 525

Senator System Manual CPE/MS 526

LJU Bell Adaptor Installation Notes CPE/MS 372.

Part 11 DOCUMENTATION

Part 12 SPECIFICATION

12.1	MAINS SUPPLY	Selectable to 220, 230, 240 or 250 volts a.c. 50Hz Nominally 240 volts a.c. + 6.5% to -8.5%.
12.2	POWER CONSUMPTION	200W maximum
12.3	DIMENSIONS	Width 530 mm Depth 2220 mm Height 275 mm
12.4	WEIGHT	11.5 kg
12.5	ENVIRONMENT	Temperature - 0° to 50° centigrade
12.6	TRANSMISSION LIMITS	Extension line limit for dedicated terminals ... 250 ohms Extension line limit for external extensions ... 1250 ohms (via External Extension Adaptor) (250 ohms is equivalent to 1.5 km of 0.5 mm copper cable) SSDC5 limit for Inter PBX Adaptor 25 ohms These limits are not in addition to the normal exchange line limit of 1250 ohms. The total loop resistance from the extension to the public exchange must not exceed 1250 ohms.

Part 12 SPECIFICATION

Part 12 SPECIFICATION

Part 12 SPECIFICATION
