

DISTRIBUTION		GENERAL	
REFERENCES			
DRGS.		SPEC. D1000	
SD 62			
ASSEMBLY DRG.		WIRING DATA	
90158			
FILE 336/1	BTT. DC.	SPEC.	
SCALE $\frac{2}{1}$	AND AS INDICATED	3RD ANGLE PROJECTION	
DECIMAL DIMENSIONS NOT CLEARED SUBJECT TO $\pm .010$			
APP'D. IN S/ SECTION	DRN. G.E.C.		
<i>Asst. Genl.</i>	TCD. G.E.C.		
	CKO CONTRS.		
	DATE 15-12-54.		
AMENDMENT		SUFFIX	
* ADDED TO 130" Dia. SEC. A-A NOTES & REFERENCE TO CHARS & CODE No. AMENDED.		A	
SHT. 2 AND NOTE RE. ALTERNATIVE CONSTRUCTION ADDED.		B	
SUPERSESSION NOTE ADDED.		C	

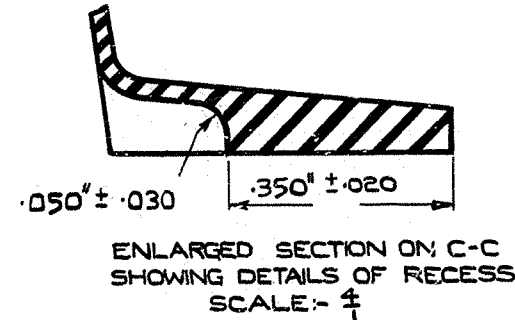

MOULD IDENTIFICATION MARKING & MATERIAL DISTINGUISHING LETTER 'D' ON THE UNDERSIDE IN $\frac{1}{16}$ " (APPROX) CHARACTERS RAISED .010" MAX. POSITION APPROX. AS SHOWN

SURFACE TO BE FREE FROM MOULD TOOLING MARKS & TO HAVE A GOOD FINISH.

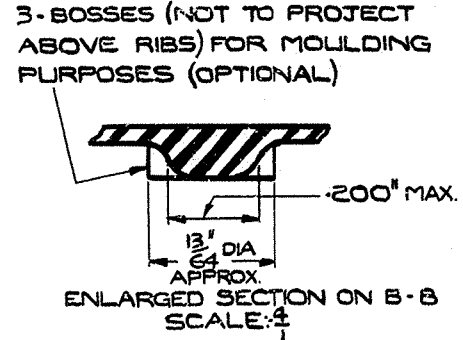
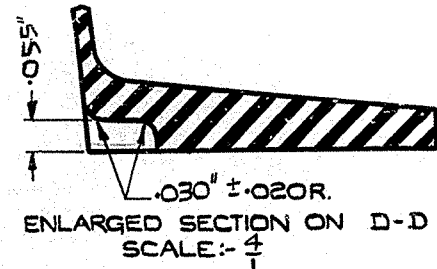
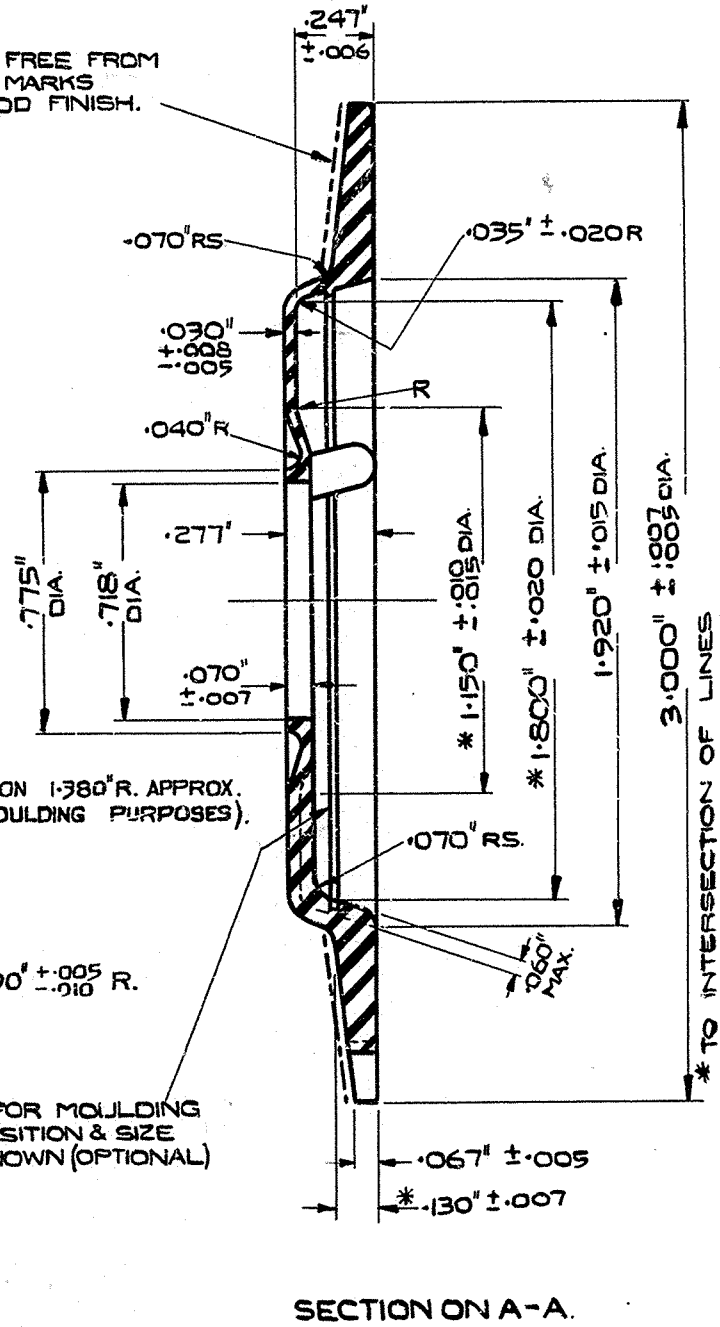
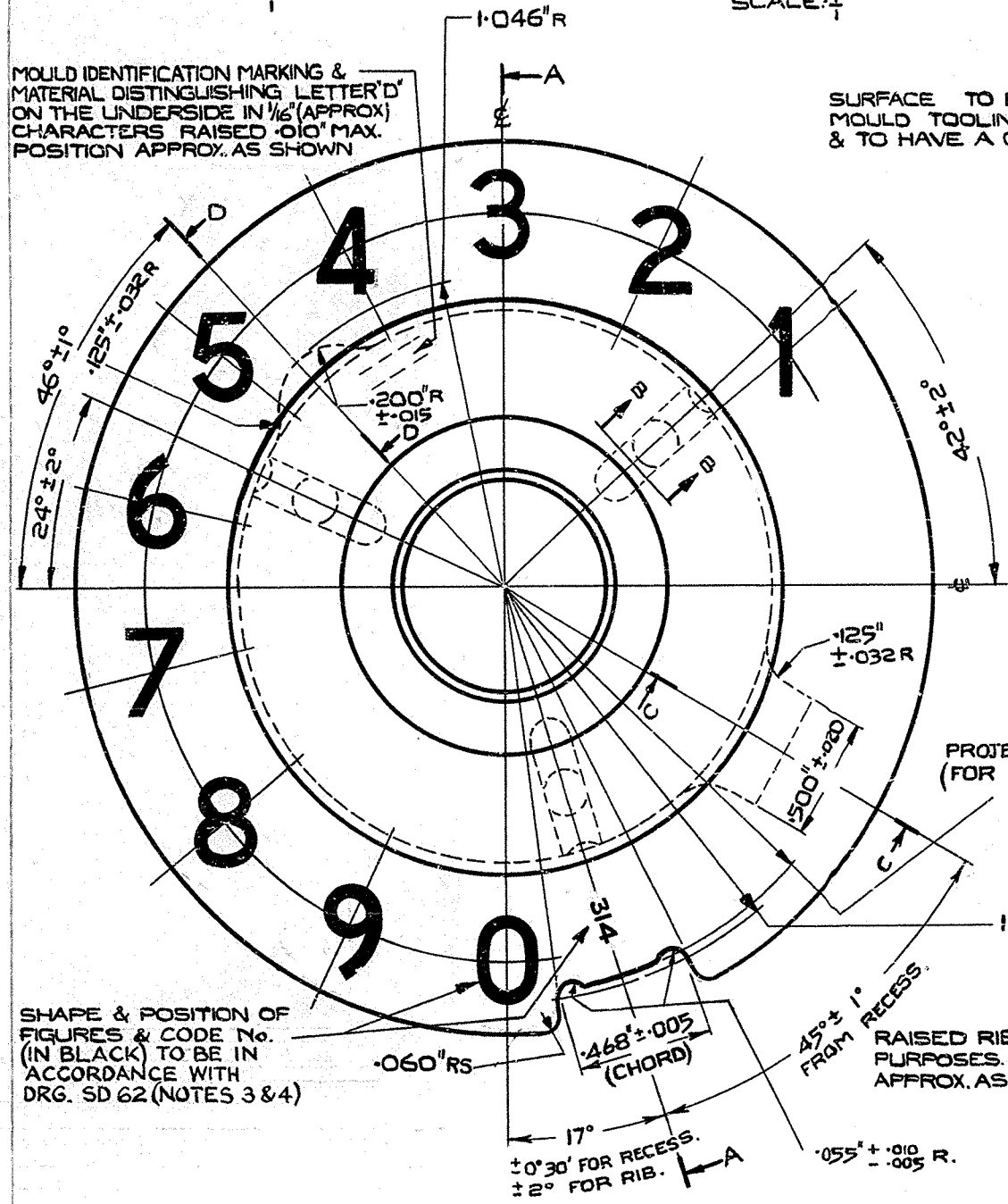

- NOTES:
1. A PATTERN OF THIS LABEL MAY BE OBTAINED FOR GUIDANCE UPON APPLICATION.
 2. SAMPLES TO BE SUBMITTED TO THE ENGINEER-IN-CHIEF FOR APPROVAL BEFORE PROCEEDING WITH BULK MANUFACTURE.
 3. FULL SIZE NEGATIVES OF SD 62 ARE AVAILABLE FOR MANUFACTURE ONLY.
 4. PRINTED CHARACTERS TO SHOW CLEARLY THROUGH RIM OF LABEL.

MATERIAL :- DIAKON 'LA', CLEAR.

FINISH :- WHITE STYRENATED ALKYD DIAL BACKING PAINT APPLIED ON UNDERSIDE OF LABEL (AFTER PRINTING OF CHARACTERS)

FIRST USE :- DIAL, AUTO, No. 13 (DRG. 90158)

ALTERNATIVE METHOD OF CONSTRUCTION SEE SHEET 2

C
P. 54484

FOR SUPERSEDED ITEM FOR NEW WORK SEE DRG. 90156 (LABEL No. 304)

LABEL
No. 314