

PART SECTION X - X
(ITEM 5 OMITTED)

NOTE :-
OVERALL DIMENSIONS ARE APPROX.

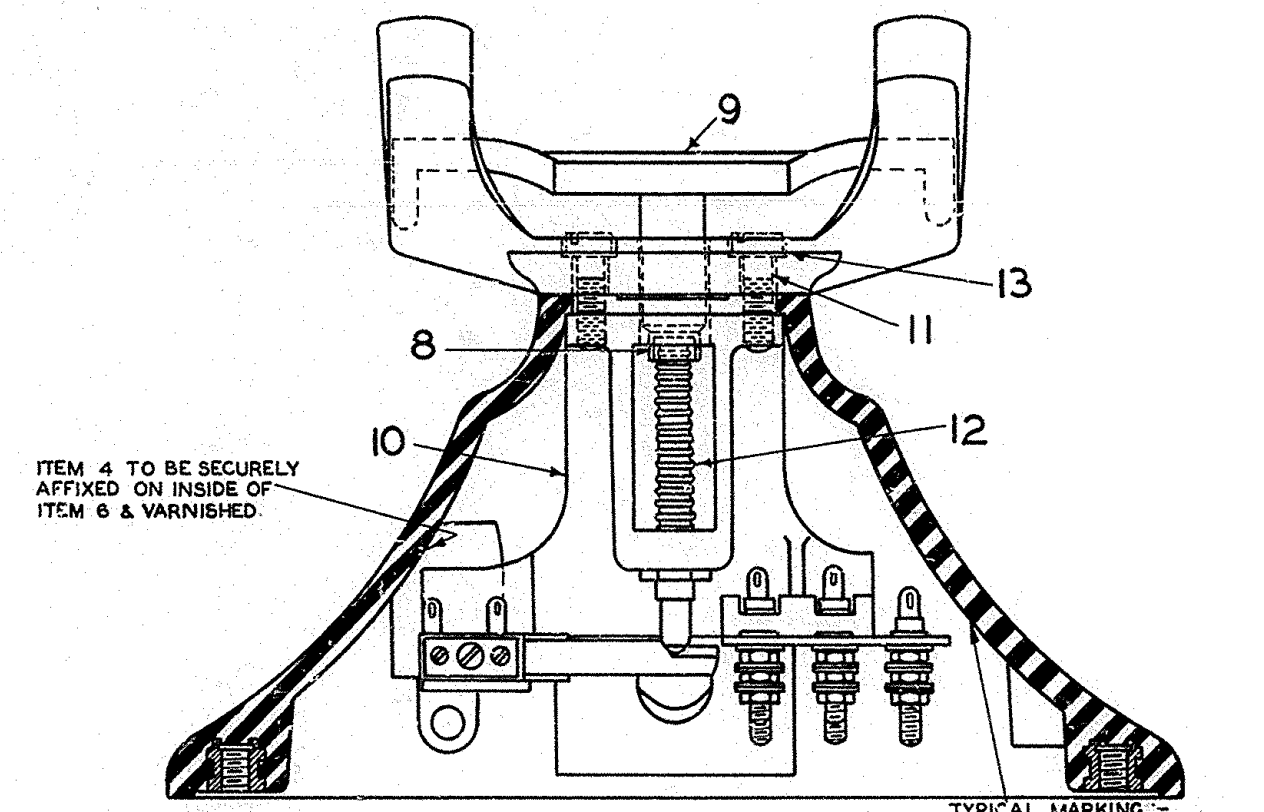

PART SECTION Y - Y
(ITEM 5 OMITTED)

TYPICAL MARKING :-
"264F. FH. 54/2" ON INSIDE OF
ITEM 6. (SEE SPEC. D1000)

COMPONENTS				SCHEDULE	
ITEM	DESCRIPTION	DRG. OR DGM.	SPEC.	QUANTITIES	
				TELEPHONE No's	
				264 F	264 L
1	CORD INST. No. 5/21 E3"	62285		1	1
2	DIAL AUTO. No. 13 FA	90158		1	1
3	DIAL AUTO. No. 20LA			1	1
4	LABEL DGM. N.364	N.364		1	1
5	TELEPHONE No. 184 BLACK MK.2 WITH CORD INST. No. 3/99 BN 26"	9509/1		1	1
6	2/SCA/37 (CASE HAND MICROPHONE)	SCA/37		1	1
7	1/SCR/1 (BLACK) (CRADLE)	SCR/1		1	1
8	2/SCU/1 (CUP, METAL)	SCU/1		1	1
9	1/SPL/321 (BLACK) (PLUNGER COMPLETE)	SPL/321		1	1
10	1/DSW/16 (SWITCH ASSEMBLY)	DSW/16		1	1
11	3/SSC/17 (SC. No. 2.B.A. SPECIAL)	SSC/17		2	2
12	3/SSP/513 (SPRING, SPIRAL)	SSP/513		1	1
13	1/SWA/72 (WASHER, SPRING)	SWA/72		2	2

POST OFFICE ENGINEERING DEPT.
E-IN-CE OFFICE S BRANCH

DISTRIBUTION
GENERAL

REFERENCES

SEE SCHED

ASSEMBLY DRG

FILE

SCALE - 1/1 AND AS INDICATED

ORIGINAL DIMENSIONS NOT TOLERANCED SUBJECT TO -

APPROD IN SI/1 SECTION

DATE 14.12.54

AMENDMENT

ITEM 5 CORD WAS 3/63 KB 33"
" 11 WAS 1/SSC/17 & QTY. 1 EACH
" 13 QTY. WAS 1 EACH.
A.T.C. 11/12-244. 13.7.61

TELEPHONE No.
264...BLACK (MK.2)

DRG. 90547