

CORNERS TO BE SECURELY JOINED AND GAPS FILLED BY WELDING, BRAZING OR SILVER SOLDERING

SHARP CORNERS TO BE REMOVED

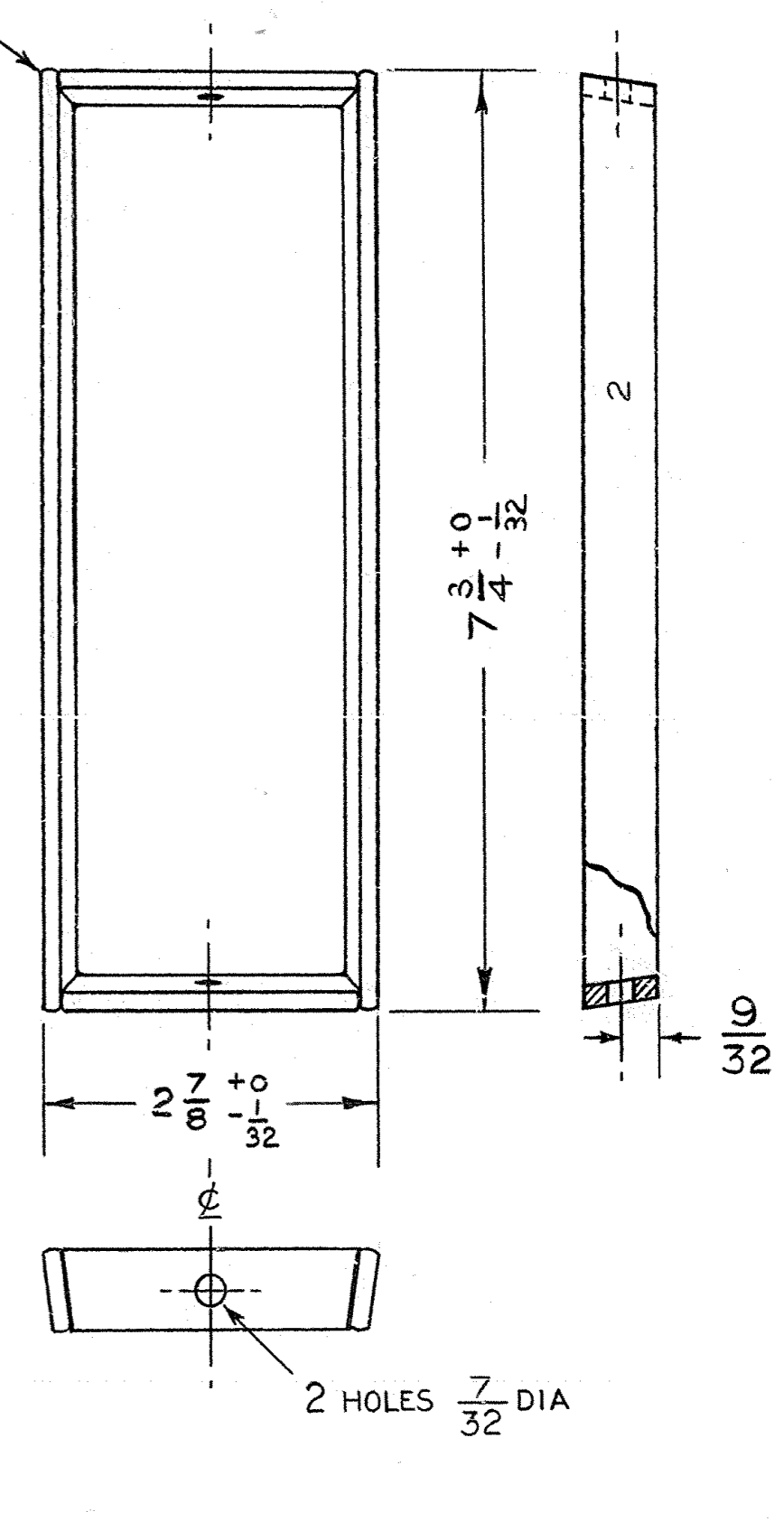
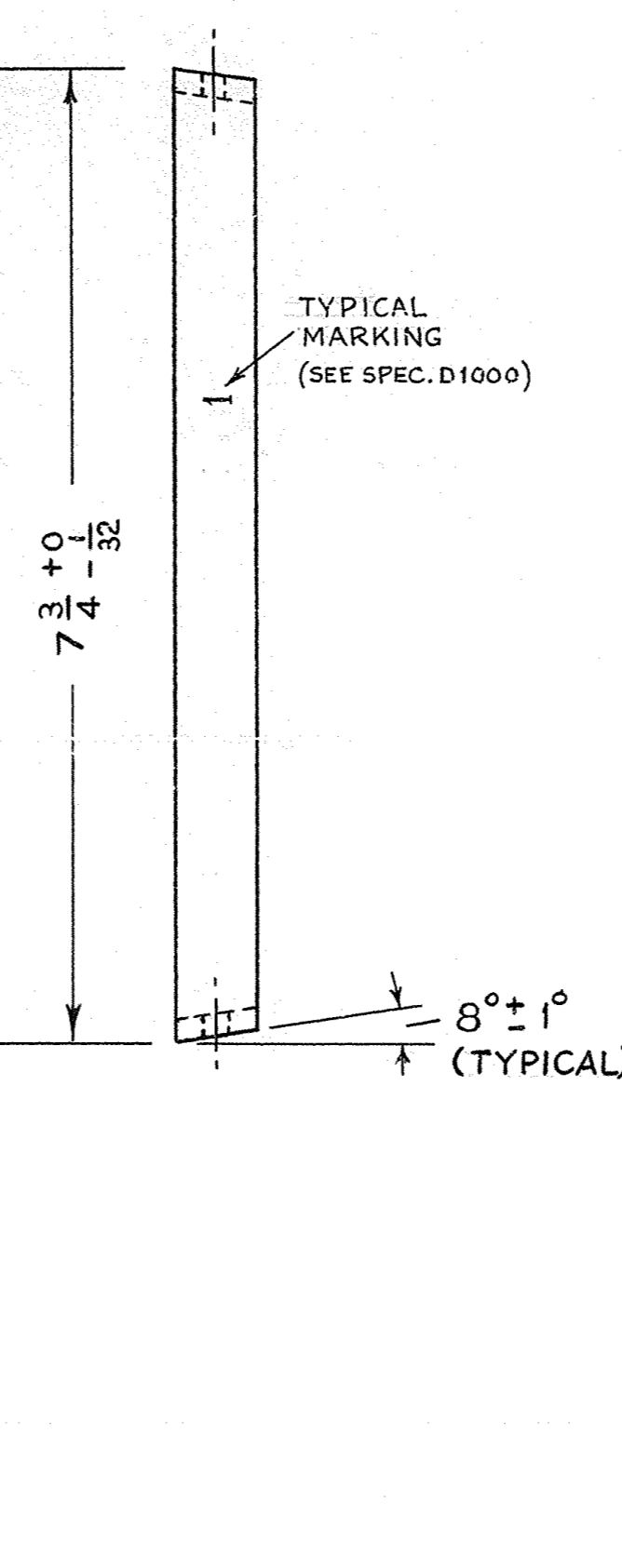
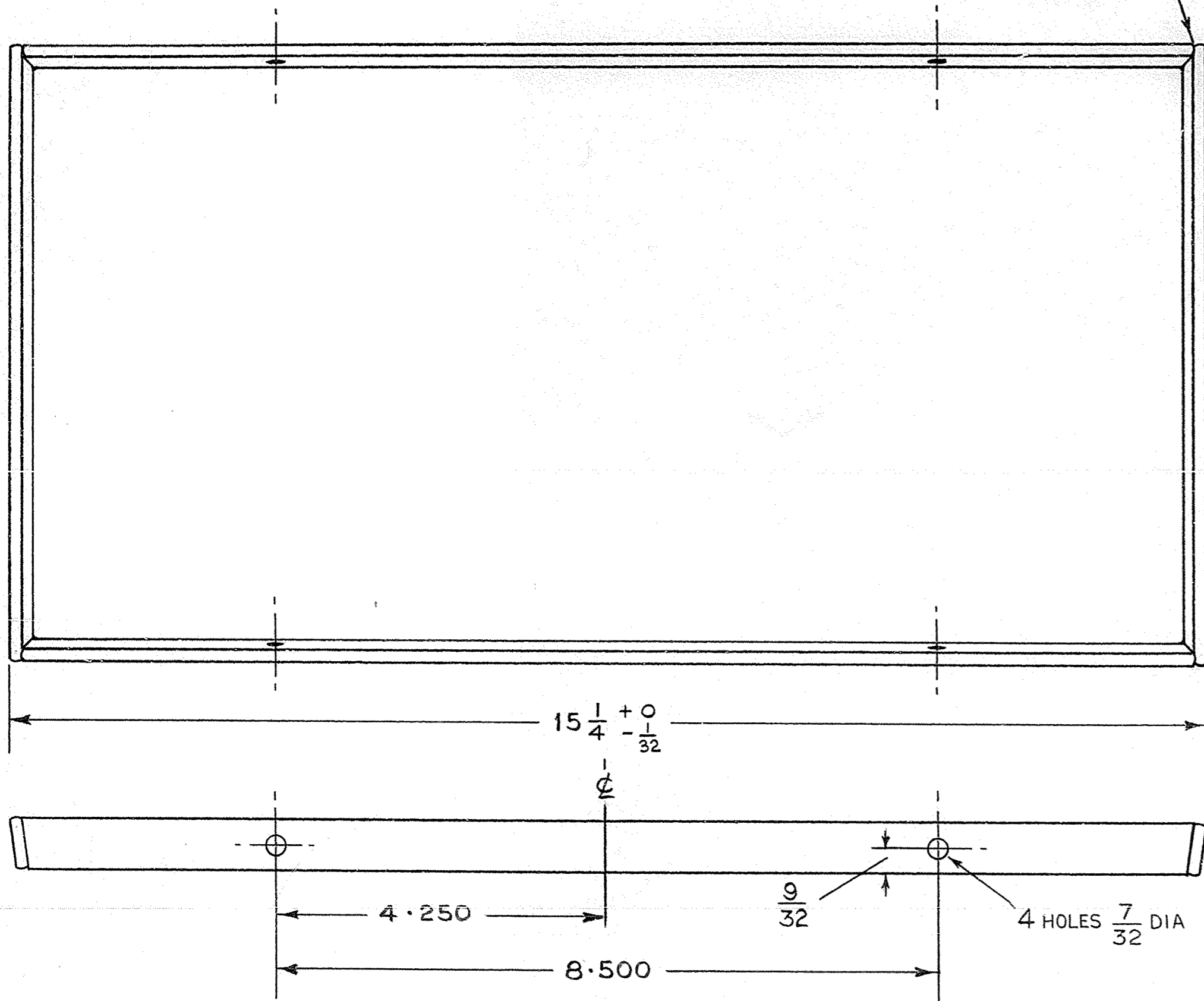

FRAME, GLAZING No.1

FRAME, GLAZING No.2

ALTERNATIVE DESIGN TO DRG.90783 SHEET 1-2

DIMENSIONS IN INCHES

REMOVE ALL BURRS

DO NOT SCALE

AI A2	CDN <i>gml</i>	TOLERANCES, EXCEPT WHERE STATED OTHERWISE :- DECIMALS ± .005" FRACTIONS ± 1/64	MATERIAL M.S. 9/16 x 5/32 ROUND EDGED	FINISH SPECS. M37 & M288 COLOUR: RED, No. 539 SPEC. B.S. 381 C	REFERENCES SPECS. M37 & M288 SPEC. B.S. 381 C SPEC. D1000
	CKD <i>gml</i>				
	CERTIFICATION	FRAMES, GLAZING Nos. 1 & 2 ALTERNATIVE DESIGN			
THO 4651	DATE 17.3.72	AMENDMENT	ISSUE	POST OFFICE TELECOMMUNICATIONS HQ TD 2.3.3 SECTION	90783 SHEET 2