

REF.	DESCRIPTION
a	15 DIA.
b	TPD. M6 x 15mm DEEP
c	TPD. M6
e	TPD. M4 x 10mm DEEP (NOTE 2)
f	TPD. M6
g	10 DIA. DEEP CSK.
h	TPD M2 x 30mm DEEP

NOTES.

1. RADII IN CASTINGS TO BE 4 ± 0.5 UNLESS OTHERWISE STATED
2. 'e' HOLES MAY BE DRILLED THROUGH AND ENDS PLUGGED.

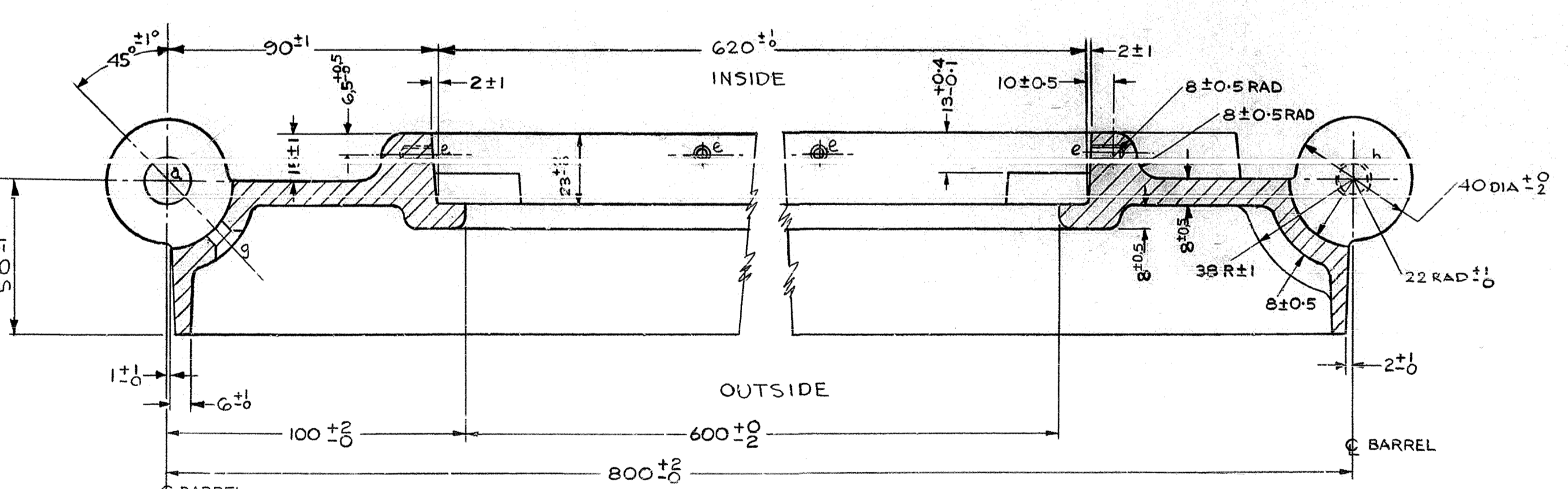
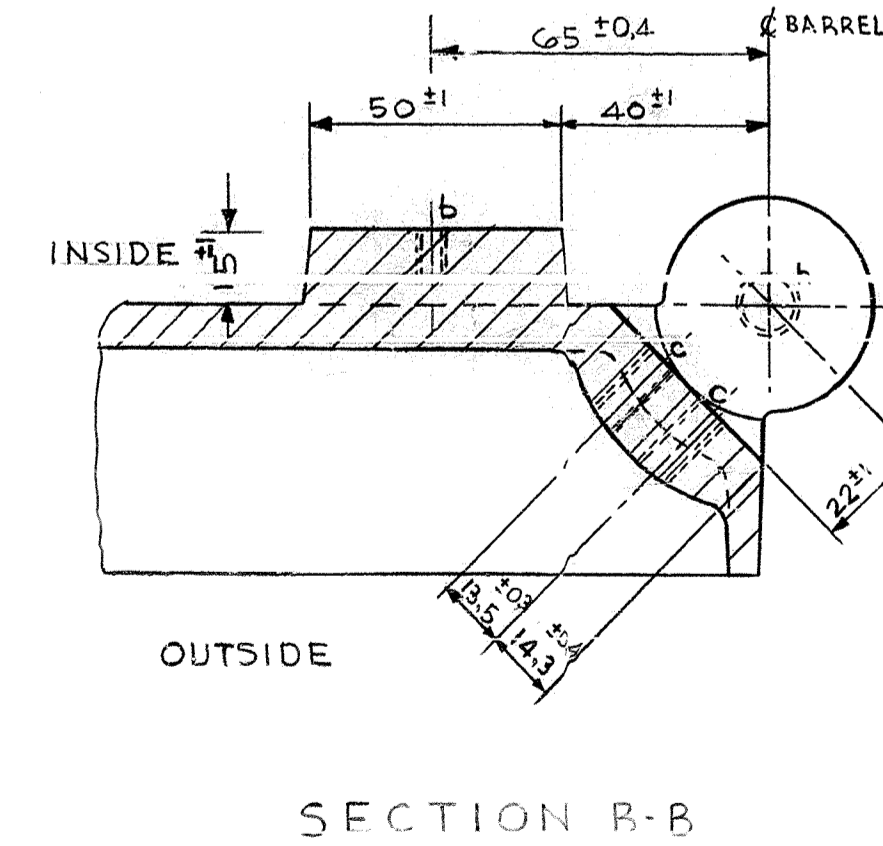
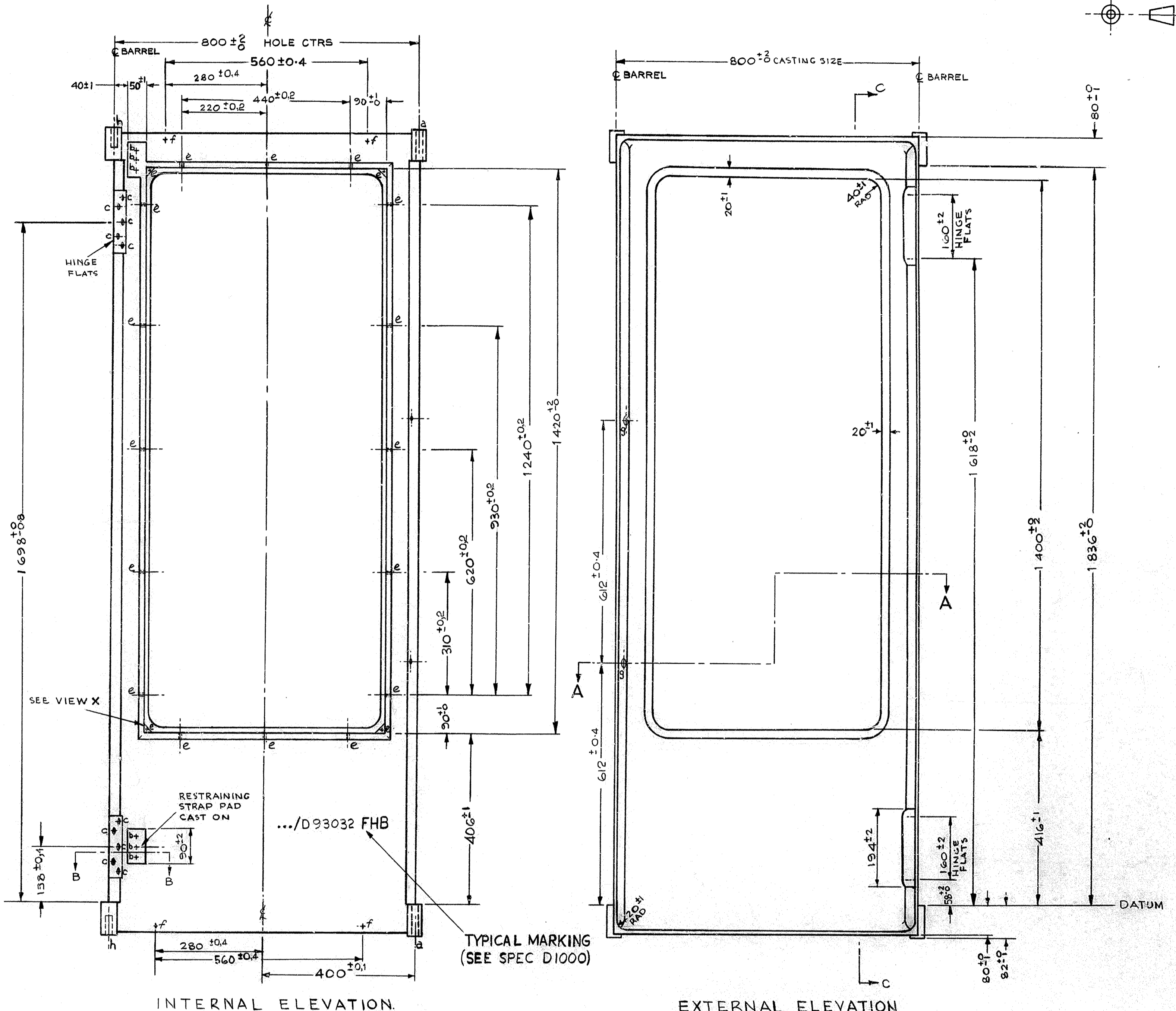

FIRST USE - KIOSK No. 8 (DRG. 93005)

DIMENSIONS IN MILLIMETRES

SIDE 1/D93032 AS DRAWN BUT WITHOUT HINGE FLATS & PADS.
 SIDE 2/D93032 AS SIDE 1/D93032 TO OPPOSITE HAND.
 SIDE 3/D93032 AS DRAWN.
 SIDE 4/D93032 TO OPPOSITE HAND.

DRN	CONTR	AO
CKD	CONTR	AI
CERTIFICATION		
DATE		

© THE POST OFFICE 1974

UPDATED. TOLERANCES REVISED. HOLE 'h' ON SECTION B-B WAS HOLE 'a' 30-7-74
 HOLE 'g' DEPT. TOP 20mm DEEP
 HOLES 'a' & 'h' 1.2mm DIA.
 APPENDIX

MATERIAL	FINISH	REFERENCES
SEE SPEC D2437	SEE SPEC D2437	SPEC D1000 SPEC D2437
SIDE D93032		