

TELEGRAPH MACHINES - THE TELEPRINTER No. 7

CONTENTS

	Page
INTRODUCTION	1
MOTOR SPEED CONTROL	2-3
KEYBOARD AND TRANSMITTING UNIT	3-11
RECEIVING AND SELECTING MECHANISM	11-18
THE CLUTCH AND TYPEHEAD	18-23
RIBBON-FEED MECHANISM	23-24
THE CARRIAGE	24-31
FIGURE AND LETTER SHIFT FACILITY	32-33
THE ANSWER-BACK FACILITY	33-34
THE AUTOMATIC MOTOR SWITCH	34-35
LOCAL RECORD	36
THE OVERLAP CAM UNIT	37-43

INTRODUCTION

The most common item of telegraphic machinery is the teleprinter. The teleprinter is rather like a large typewriter in appearance. It is powered by a fractional horse-power electric motor which drives the mechanism, enabling transmission and reception of messages using the five unit code.

The basic teleprinter consists essentially of two main units, namely,

- (i) the transmitter, and
- (ii) the receiver,

which are mounted on the same base-plate. Both the transmit and receive mechanisms are at rest except when a signal is being sent or received.

The machine is enclosed by an easily removable cover made of metal, and having a transparent flap, through which may be seen the platen. The inside of the cover, and its base, is covered with thick felt, or a similar material, to reduce the noise from the working parts of the mechanism.

When a certain speed is exceeded the centrifugal force acting on the contact arm is sufficient to overcome the tension of the spring and break the two contacts. This allows the governor resistance to be inserted in the series motor circuit. The current is therefore reduced and this in turn reduces the torque and the speed is reduced until the governor contacts restore and close to short circuit the governing resistance again. When this occurs the current again begins to rise and the torque increases which in turn increases the speed. The cycle of events then repeats itself. Examination of Fig. 2 shows that the spring tension can be adjusted so that the speed can be adjusted to within fine limits. Electrical contact is made by two spring loaded carbon brushes, mounted on an insulated block on the motor casting, bearing on two slip rings fixed to the rear of the governor base. The slip rings are shown as dotted lines in Fig. 2. The governor maintains the speed of the motor at 3000 rev/min.

KEYBOARD AND TRANSMITTING UNIT

Introduction

The transmitter is simply an automatic signalling device driven by the teleprinter motor and controlled by the keyboard. When a key is depressed, its position across five metal bars known as combination bars determines the code transmitted and a combination of pulses of negative (marking) and positive (spacing) potential are applied to the line.

The five unit code is used on all teleprinters in the B.P.O. i.e. when any key is depressed a combination of five pulses of positive and negative potential are applied to the line, each combination being preceded by a spacing pulse and followed by a marking pulse as illustrated in Fig. 3(a) where the code for letter Y is shown.

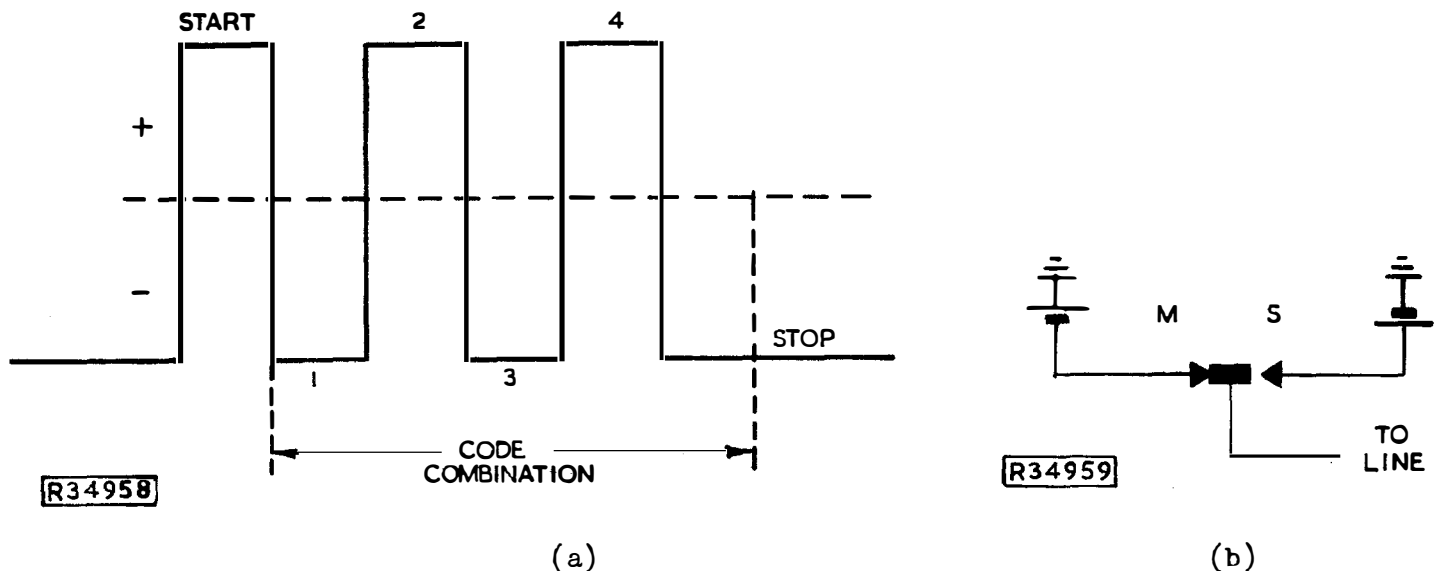

Fig. 3

In order to be able to send signals in this form, the transmitter consists essentially of a tongue which can be moved between two contacts one of which is connected to an 80V -ve potential and the other to an 80V +ve potential. The standard symbol used on diagrams to represent a transmitter is given in Fig. 3(b).

A picture of the keyboard and transmitting unit is shown in Fig. 4.



R 36149

Fig. 4

Fig. 5 shows a schematic diagram of the transmitting mechanism.

Fig. 5
5.

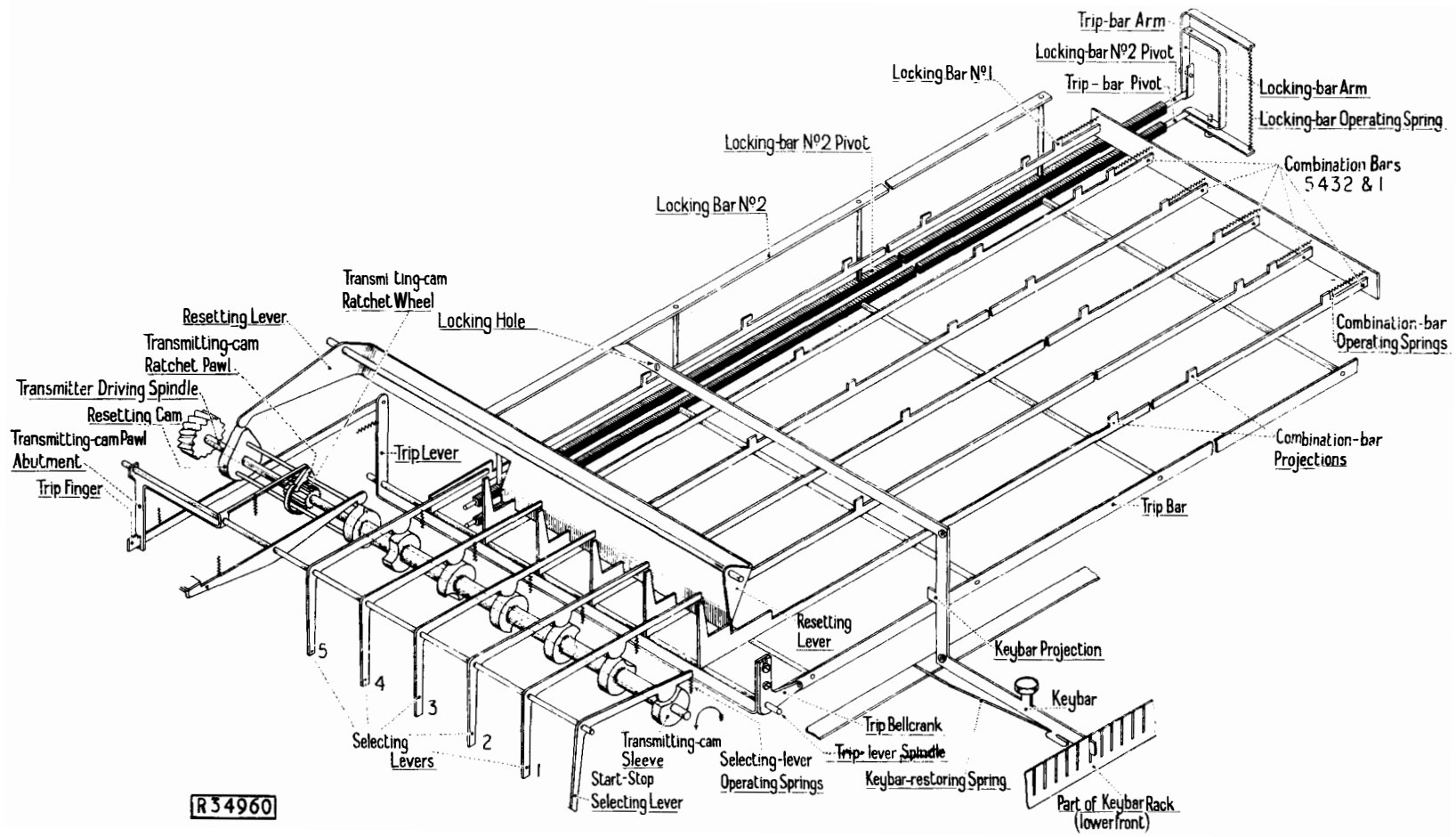

DEPRESSION OF KEY ON KEYBOARD

With the teleprinter motor running, i.e. the teleprinter ready for instant use, the keyboard driving gearing rotates the inner spindle and the transmitting cam ratchet wheel. Consider now what happens when a key is depressed. Fig. 6 is a line diagram showing the front elevation of the essential components of the transmitting unit.

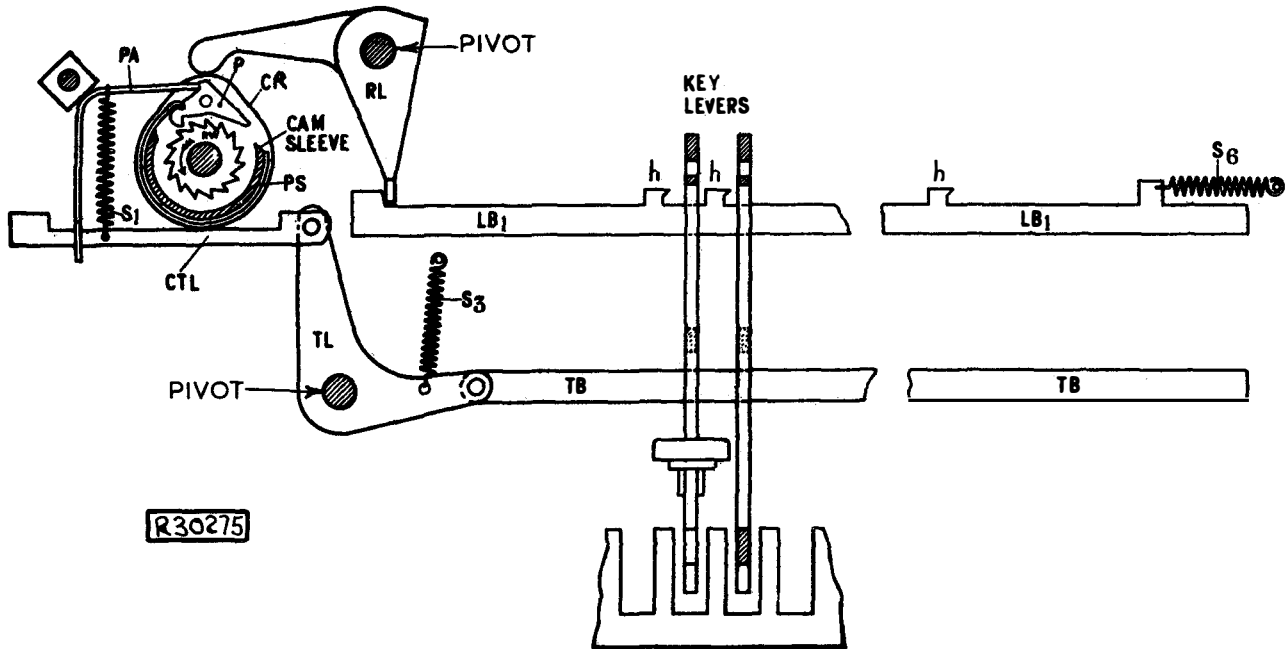

Fig. 6

When any key is depressed, the key bar projection, Fig. 6, on the vertical part of the key operates the trip bar (TB). The trip bar (TB) moves downwards and causes the trip lever (TL) to move the cam trip lever (CTL) to the right. The projection on this latter lever (CTL) engages with the lower end of the pawl abutment (PA) turning the latter in an anti-clockwise direction so lifting the upper extremity away from the pawl (P). The pawl (P) which is under tension from springs, now engages with the ratchet wheel which is rotating and the transmitting cam rotates in an anti-clockwise direction with the driving gearing. As soon as the transmitting cam begins to rotate, the cam reset projection (CR) on it moves away from the resetting lever (RL) thus allowing the locking bar No. 1 (LB1) to move to the right under the control of the locking bar spring (S6). The hooked teeth (hh) on this bar engage with the hole in the depressed keybar thus holding it depressed until the transmitting cam has rotated once. The movement of the resetting lever (RL) also allows certain of the combination bars, Fig. 5, to move to the right under the control of their respective springs. Each of the combination bars have projections, two of which are shown at A and B in Fig. 7.

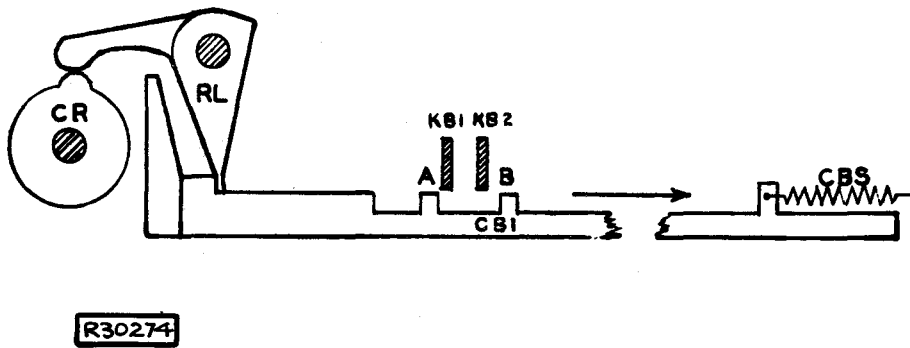

Fig. 7

In this diagram a front elevation is drawn showing the projections of two key-bars KB1 and KB2. If key KB1 is depressed then the combination bar will be prevented from moving to the right. On the other hand, should key KB2 be depressed then the combination bar will be allowed to move to the right.

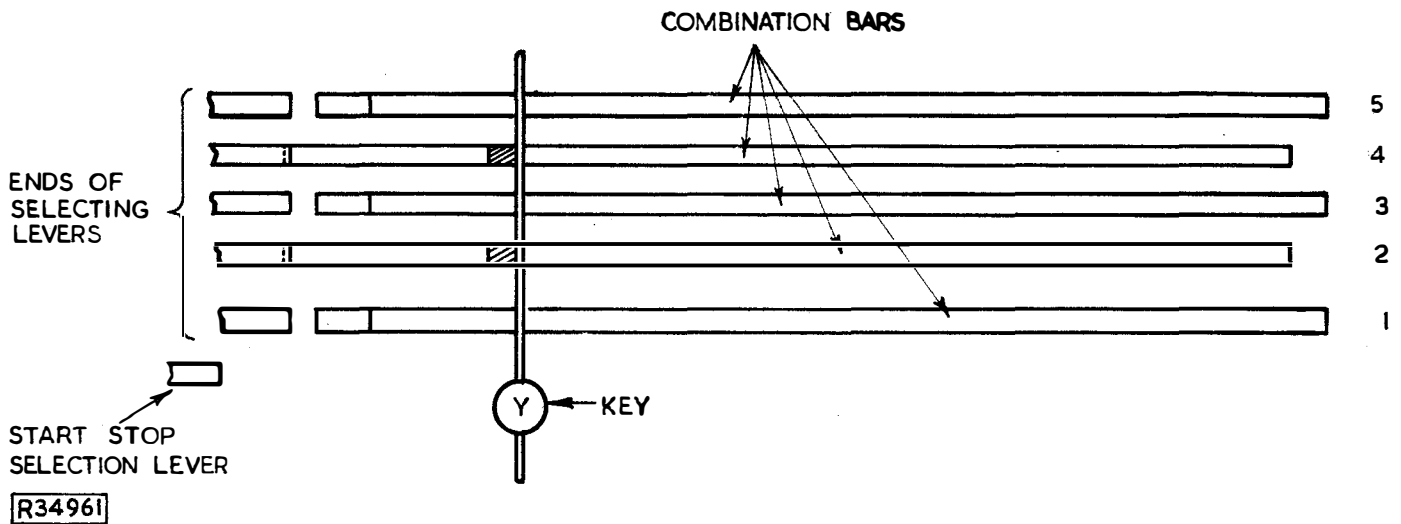

Fig. 8

Fig. 8 shows a plan of the combination bars, and the ends of the selecting fingers with a depressed 'Y' key. It will be seen that combination bars 1, 3 and 5 are allowed to move to the right while combination bars 2 and 4 are prevented from moving to the right by the projections on the combination bars immediately to the left of the keybar.

The transmitting cam is made up of six cams and each cam has a slot cut in its periphery in which the corresponding selecting lever may ride. As the cam shaft rotates, each selecting lever is in turn permitted to ride over the cut away portion of the cam providing the corresponding combination bar has moved to the right to allow the top end of the selecting lever to move down. Such a downward movement constitutes a mark element. The cut away portions of the transmitting cams are so arranged that they pass any fixed point in the order 1, 2, 3, 4 and 5, this is illustrated in Fig. 9, where the cam profiles are shown; the diagram indicates them in their correct phase, relative to one another.

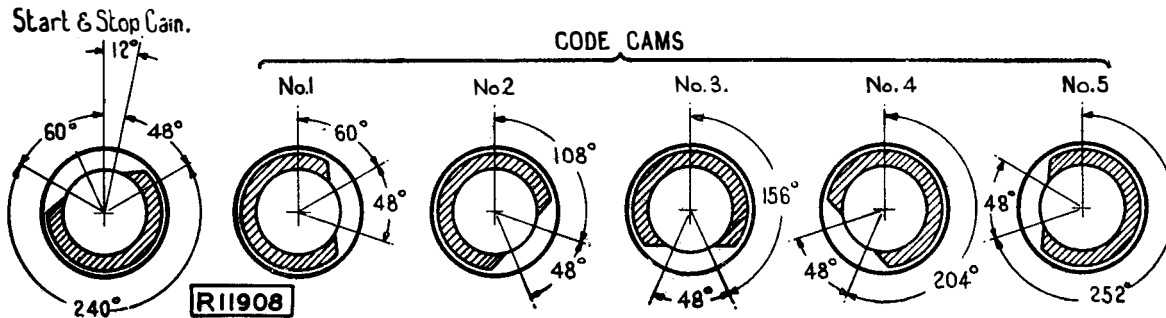

Fig. 9

The transmitting cam of the Teleprinter No. 7 rotates at 400 rev/min. i.e. it makes one revolution in 150 ms and thus it will rotate 48° in 20 ms. The track nearest to the front of the machine controls the sending of the start and stop elements of the character combination. When the transmitter is at rest, the start stop selecting lever is resting in this recess and causes the transmitting tongue to be held on the marking contact. The start element (space) is sent during the interval from 12° to 60° . Cam tracks 1 to 5 control the transmission of the five code elements and are cut away for 48° arcs successively between 60° and 300° as shown in Fig. 9. Thus the code selecting levers will ride into the cut away portions successively for 20 ms periods provided they are permitted to do so by the setting of the combination bars.

In addition to the selecting lever-cam tracks, of course, the cam sleeve also has two cams which control the operations of the send and receive switch and the resetting lever respectively.

THE STRIKER TYPE TRANSMITTER

A picture of a teleprinter transmitter and the associated selecting levers is shown in Fig. 10. This type of transmitter is known as the striker type by virtue of its action. The transmitter is situated immediately to the left of the selecting levers when viewing from the front.

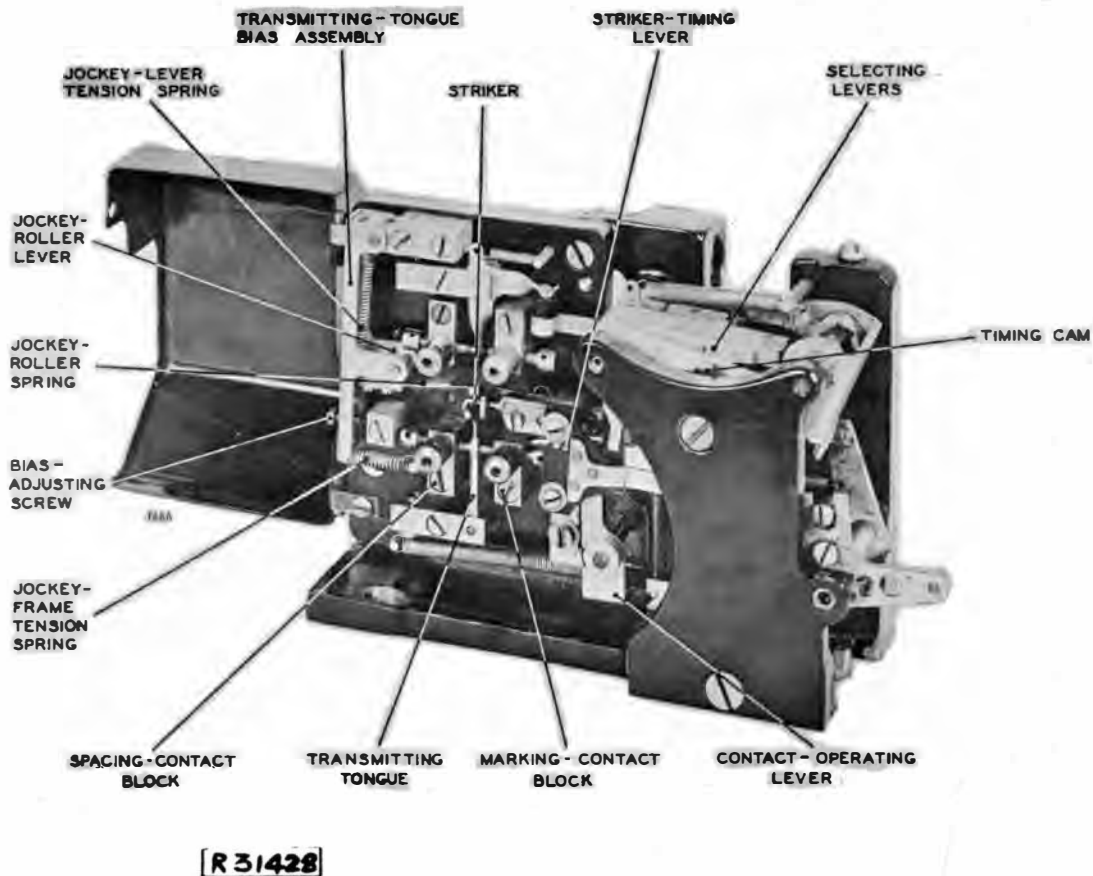

Fig. 10

Fig. 11 is a diagram showing the action of the transmitter. A timing cam is fitted on the end of the cam shaft and it moves the striker up and down at regular intervals during the revolution of the cam. The left hand end of the striker is bent downwards and shaped with a knife edge. This knife edge is caused to operate on a similar knife edge on the upper end of the transmitting tongue. When a marking signal is to be transmitted, the appropriate selecting lever enters the cut away portion of the cam track and moves the contact operating lever and striker to the left, i.e. to the position shown in Fig. 11. When the striker timing lever next falls into a notch in the timing cam the striker moves downward and pushes the tongue sharply over to the marking contact. The tongue is so arranged that it

remains on the marking contact until moved over to the spacing contact by another downward movement of the striker when the appropriate selecting lever is not allowed to follow the indent in its associated cam. Thus as the transmitting cam rotates, the striker moves up and down and, when appropriate moves the tongue from one contact to the other.

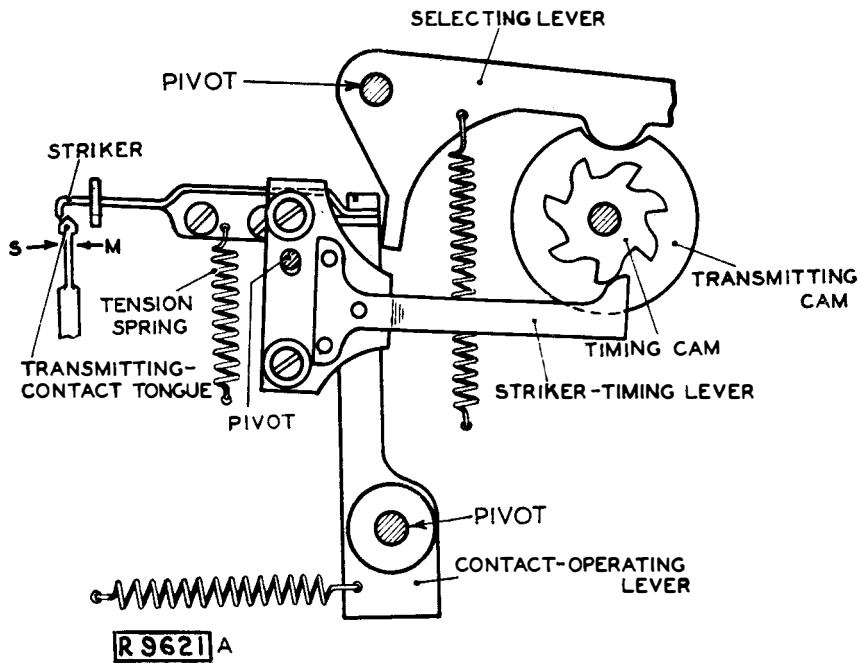

Fig. 11

Design Features

For satisfactory transmitting it is essential that the following conditions be fulfilled.

- (a) That the transmit time of the contact tongue be small.
- (b) That the contact tongue pressure is adequate.
- (c) That the contact tongue does not bounce or chatter on the contacts.
- (d) That the contact tongue transmits marking and spacing signals of equal length i.e. free from bias.

To obtain these conditions a jockey roller mechanism is employed and is located on the left hand side of the transmitting unit, see Fig. 12.

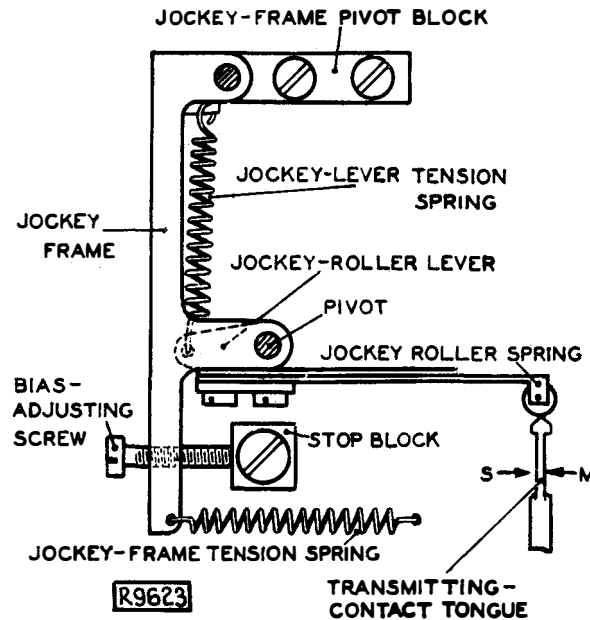

Fig. 12

The mechanism comprises a jockey frame which is pivoted on to a bearing block and a jockey roller lever assembly which is pivoted near the centre of the frame. The pressure for the jockey roller is provided by means of a tension spring. One end of this spring is anchored to the left-hand side of the jockey roller lever, the other is secured to the upper end of the assembly frame. A bias adjustment screw and a tension spring are fitted at the lower end of the frame. The tension spring pulls the lower end of the frame towards the right and the end of the bias-adjusting screw abuts against a stop-block as shown. The function of this screw is to enable the position of the jockey roller to be adjusted centrally with respect to the contact tongue knife-edge.

RECEIVING AND SELECTING MECHANISM

The incoming five unit code signals which are usually received by a polarized relay in the line circuit operate a polarized electromagnet which is mounted on the teleprinter itself. The resulting movements of the armature of this electromagnet produce the following effects.

- (a) Set in motion the selecting and printing mechanism.
- (b) Select the character which is to be printed.
- (c) Bring the mechanism to rest at the end of the signal.

THE ELECTROMAGNET

The electromagnet is shown in Fig. 13(a). It consists essentially of a U shaped permanent magnet with laminated pole pieces and a laminated armature. The movement of the laminated armature and its extension is limited by two stops. The two coils of the electromagnet almost completely enclose the armature which passes through them.

The magnetic circuit of the electromagnet is such that a marking signal causes the armature to move over to the mark stop while a spacing signal causes the armature to move over to the space stop [Fig. 13(a)].

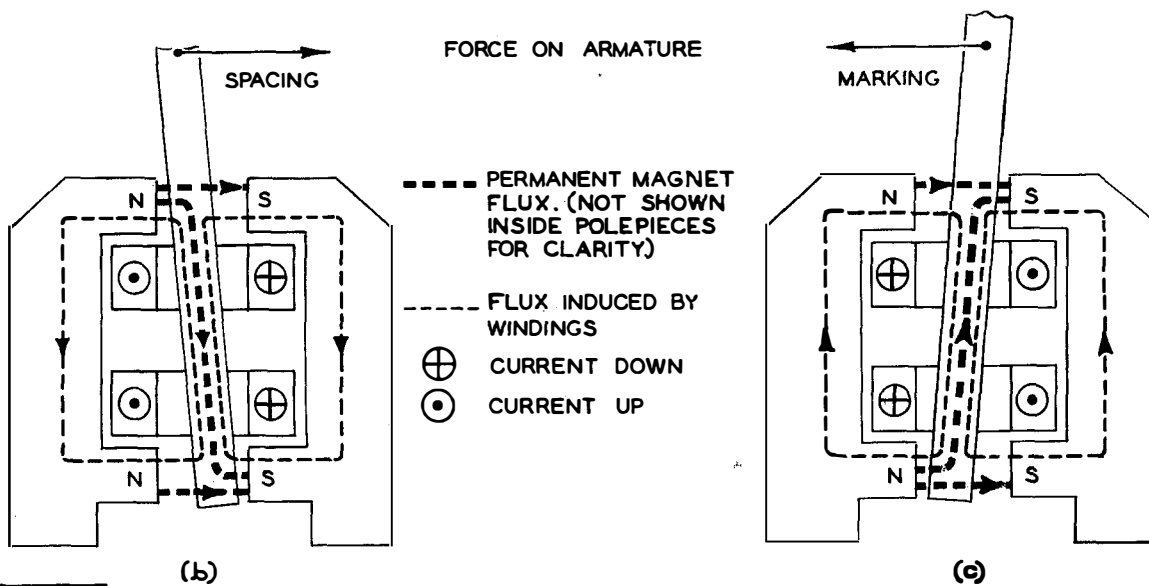
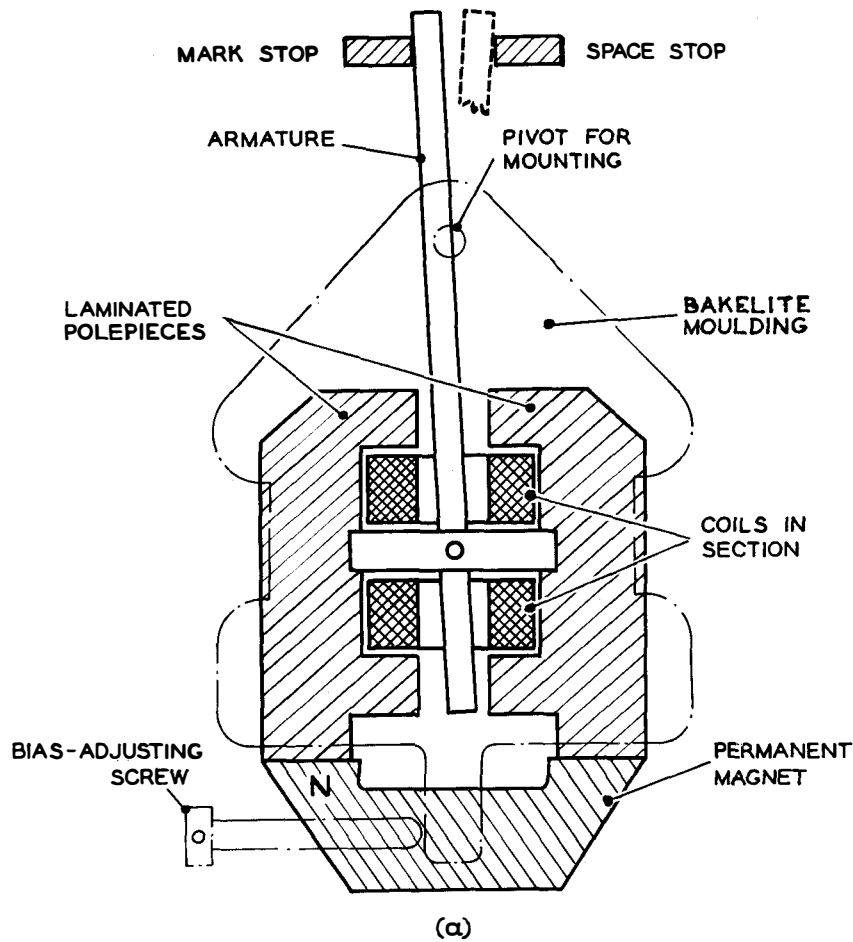

R41770

Fig. 13

The Electromagnet Link

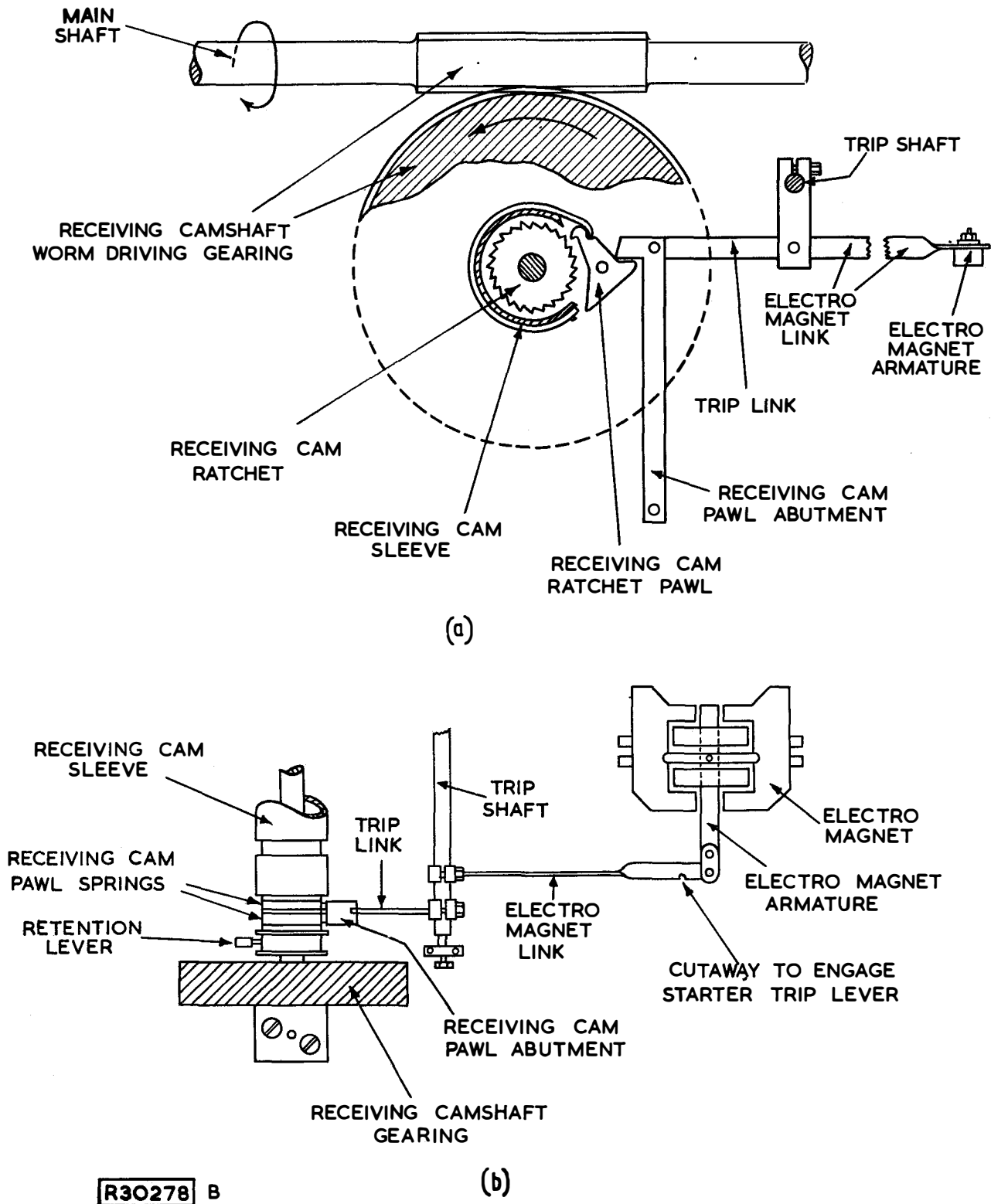

Fig. 14

The relay link couples the armature to a lever on the trip shaft as shown in Fig. 14. The link also engages with the starter trip which operates the automatic motor switch (this is not shown).

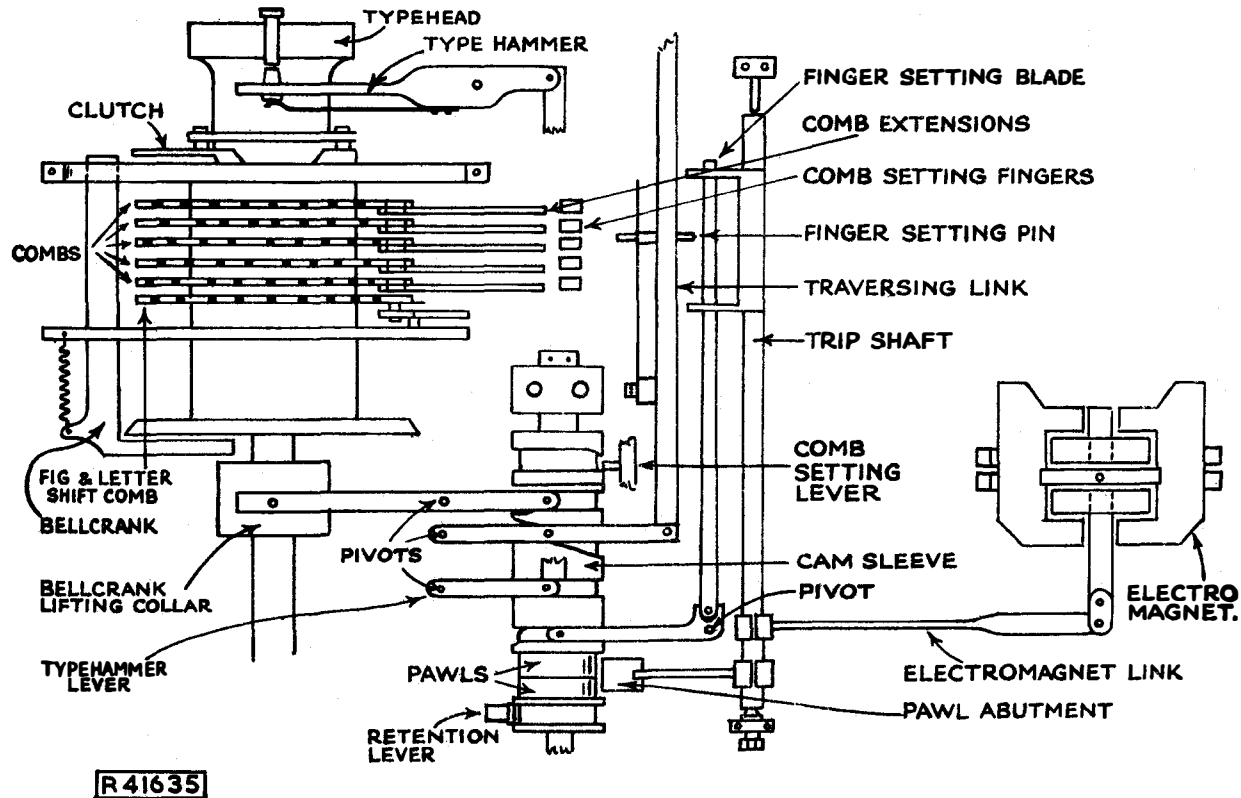

Fig. 16

The trip shaft performs two functions.

(a) it controls the starting and stopping of the receiving cam sleeve by engagement and disengagement of the pawls through the action of the pawl abutment (this is similar to the transmitting cam arrangement), and

(b) it controls the deflexion of the finger setting blade in accordance with the incoming signals and thus translates the signal code combination into a corresponding setting of the five comb setting fingers.

The Receiving Cam Sleeve Pawl Abutment

This is a lever pivoted vertically on the base of the machine and coupled to the trip shaft by the trip link. At its upper end the pawl abutment normally engages the pawls and holds them from engagement with the receiving ratchet spindle (see Fig. 14).

This portion of the mechanism closely resembles the clutch trip arrangement of the transmitting unit. In both cases there is a constantly revolving shaft which has to be engaged and disengaged at certain intervals. The ratchet wheel actually consists of two wheels having teeth of relatively wide pitch set so that they are staggered at half pitch. This arrangement is equivalent to a ratchet wheel having robust teeth with a fairly fine pitch and speeds up the engagement on receipt of the start element.

The receiving cam spindle and ratchet mechanism is driven by a wheel engaged with the main shaft and is rotating continuously whilst the motor is running. When the armature of the electromagnet moves to spacing on receipt of the start signal, the end of the pawl abutment is withdrawn from the pawls and the pawl springs force one of the two pawls into engagement with the rotating ratchet. The receiving cam sleeve therefore commences to rotate. When the armature is moved to the marking side on receipt of the stop element the pawl abutment is introduced into the path of the pawls as the cam sleeve is completing its revolution and forces the pawls out of engagement with the ratchet. Although during the reception of a five unit code signal the pawl abutment moves in and out it will not obstruct the path of the pawls as they are revolving with the ratchet wheel. At the end of the revolution then, the stop signal which is a marking element causes the pawl abutment to engage with the heel of the pawls and thus cause the latter to disengage from the ratchet. (In most line diagrams concerning both the transmitting and receiving mechanisms in this pamphlet, only one ratchet and pawls are shown for obvious reasons of simplicity).

The function of the pawl abutment can therefore be summarized thus:-

- (a) To engage the receiving cam sleeve with its continuously revolving shaft.
- (b) To disengage the pawls and bring the cam sleeve to rest.

The Receiving Cam Sleeve

The receiving cam sleeve is a steel cylinder which has five tracks cut in its surface. The shape of the tracks, shown schematically in Fig. 17, determines the movement of certain levers which riding upon rollers move in the tracks and perform certain operations to be described later. The whole of the setting up and printing operation is controlled by these 5 cam tracks.

1. Setting Blade Lever Track. This track controls the horizontal movement of the finger setting blade. This blade is mounted directly behind the finger setting pin and is caused to strike in towards the pin each time the pin passes a finger as the code signals are received.
2. The Type Hammer Lever Track. This track operates the type hammer during the stop element. The character printed will be that set up in the combination head by the previous signal combination.
3. The Traversing Lever Track. This track controls the motion of the traversing link, which carries the finger setting pin backwards and forwards across the front of the selecting fingers.

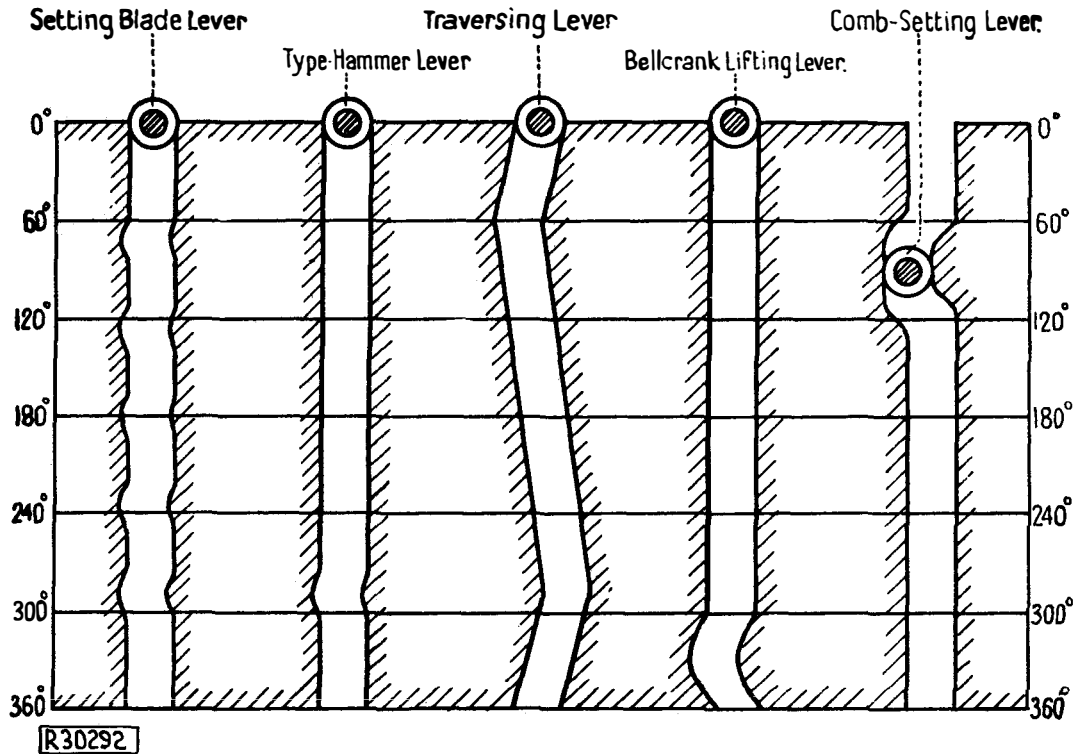

Fig. 17

4. The Bell Crank Lifting Lever Track. This track causes the operation of the bell crank lifting collar to restore the bell crank which dropped on the previous selection and to lift all the bell cranks clear of the combs as the comb setting lever turns them to their new position.

5. The Comb-Setting Lever Track. This track operates the comb setting lever just after the commencement of the rotation of the cam sleeve. When the code signals have been set up on the fingers the comb setting lever operates to raise all five fingers upwards. The fingers that have been moved underneath their comb extensions will turn their combs whilst those not moved under will miss their comb extensions and these combs will be left stationary. Thus the comb setting lever transfers the combination from the comb fingers to the combination head.

Reception Cycle

Fig. 18 gives a schematic diagram indicating the timing of the operations which make up the complete reception cycle for one character. This chart will give the student a clearer conception of the individual operations with respect to the whole sequence.

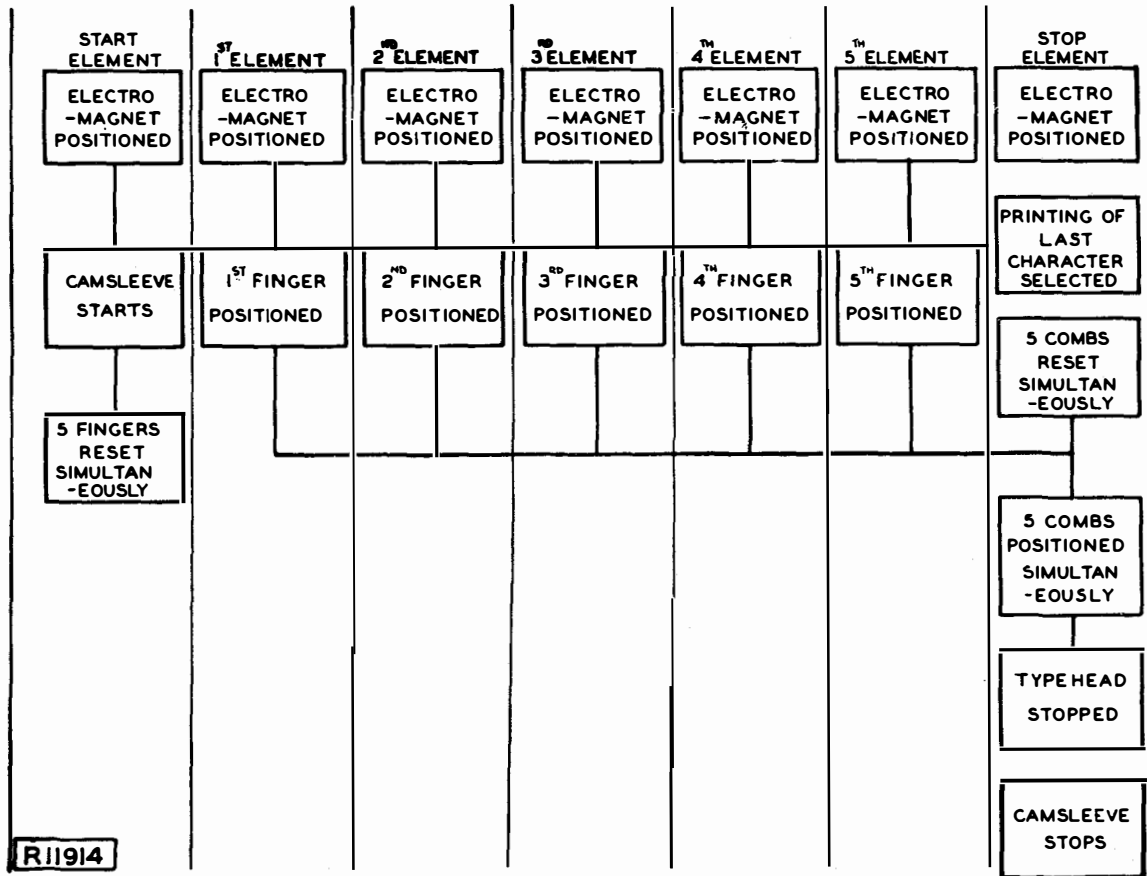

Fig. 18

OPERATION OF THE CLUTCH AND TYPEHEAD

So far, only the selection of the bell crank, corresponding to the required character, has been mentioned. When any bellcrank drops, it engages a clutch which stops the typehead with the required type opposite the type hammer.

At the present time there are two types of clutch and typehead assembly in use. However, the first of the two types to be described is now obsolescent.

The clutch is assembled in the order illustrated in Fig. 19.

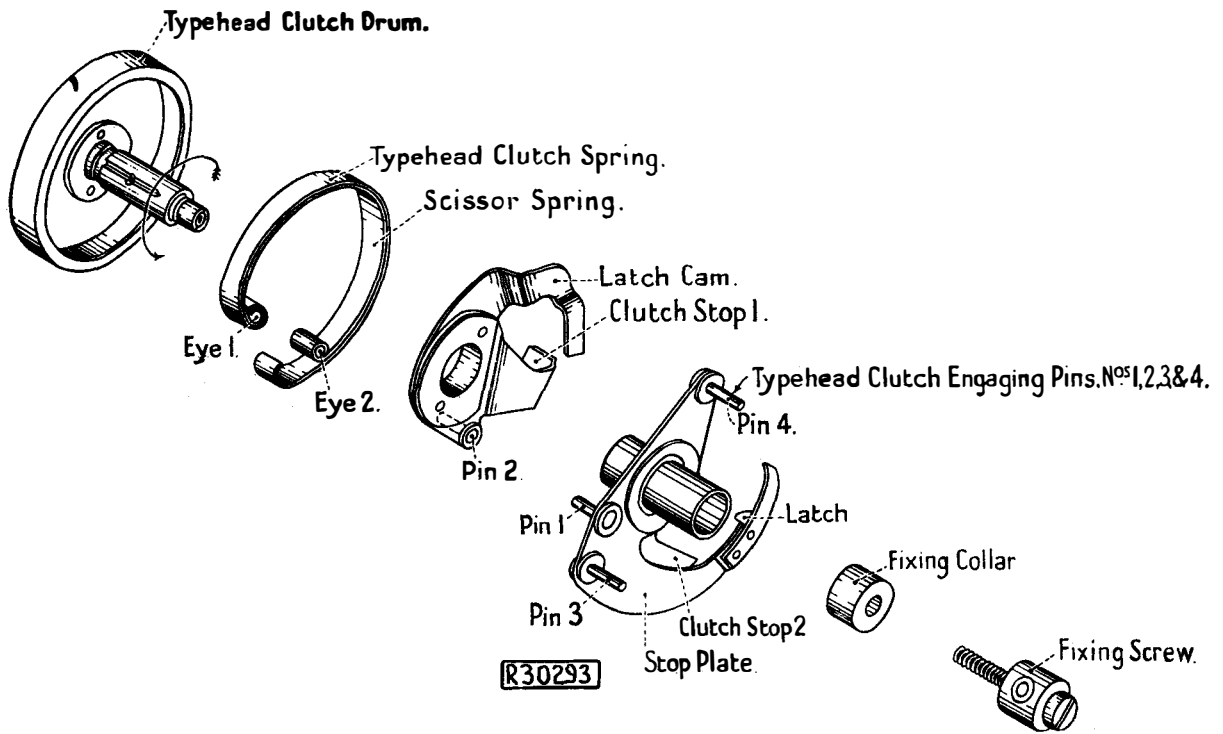

(a)

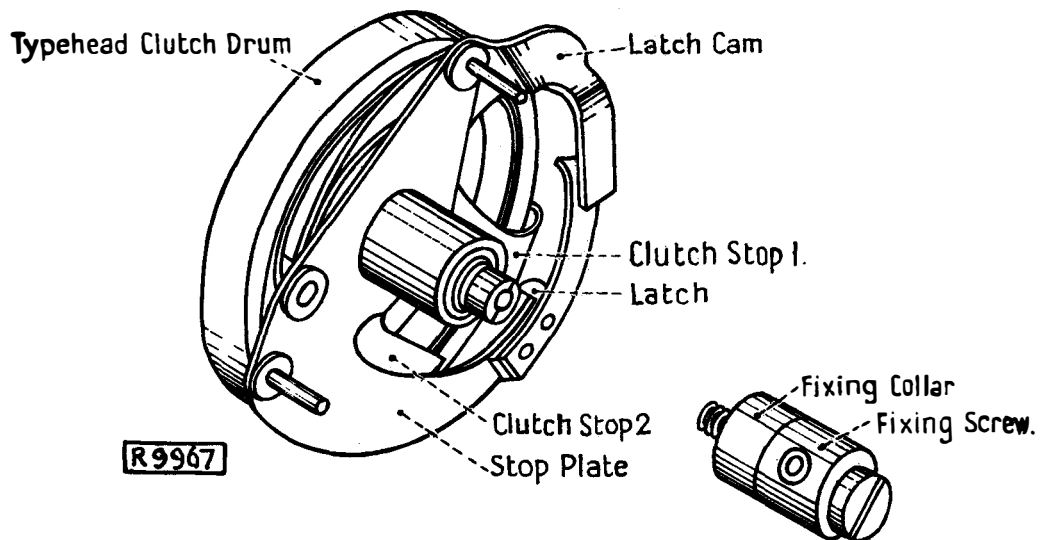

(b)

Fig. 19

The clutch drum is continuously driven in an anticlockwise direction by the typehead shaft through the motor gears. This motion is normally imparted to the stop plate and typehead through the friction between the clutch spring and the internal surface of the clutch drum. When a selected bellcrank is drawn into the receiving combs, the end of the bellcrank is introduced into the path of the clutch stop 1, which arrests its movement. The stop plate continues to revolve, however, carrying with it the typehead; but their momentum is partially absorbed by the flexure of the scissor spring. At the same time, the combined outward pressure on the clutch drum due to the clutch and scissor springs is reduced as the scissor spring is drawn inwards; the friction on the drum through which the typehead is normally engaged is consequently reduced considerably. After a small amount of independent movement, the stop 2 engages with the back edge of the stop 1, and the stop plate is brought to rest.

Just prior to the arrest of the stop plate, the scissor spring is flexed to such an extent that the eye 2 is brought into contact with the hooked or free end of the clutch spring. The retarding influence on the typehead is thereby increased due to the compression of both springs, and as the typehead comes to rest the friction clutch is completely disengaged. Simultaneously, the latch moves in beneath the latch cam and is thrust behind the selected bellcrank; recoil of the clutch due to the tendency of the clutch springs to expand is thus prevented; the typehead is, therefore, brought to rest in the position required, with the selected bellcrank opposite the type hammer.

When the selected bellcrank is reset, the scissor spring acting on the clutch stop causes it to be carried forward, and by this means the latch cam is also carried forward. The latch is thereby released and allows the typehead to be re-engaged.

The Typehead

A sectional view of the typehead is shown in Fig. 20. At the end of the typehead sleeve are two bushes which engage with driving pins No. 3 and 4 fitted on the

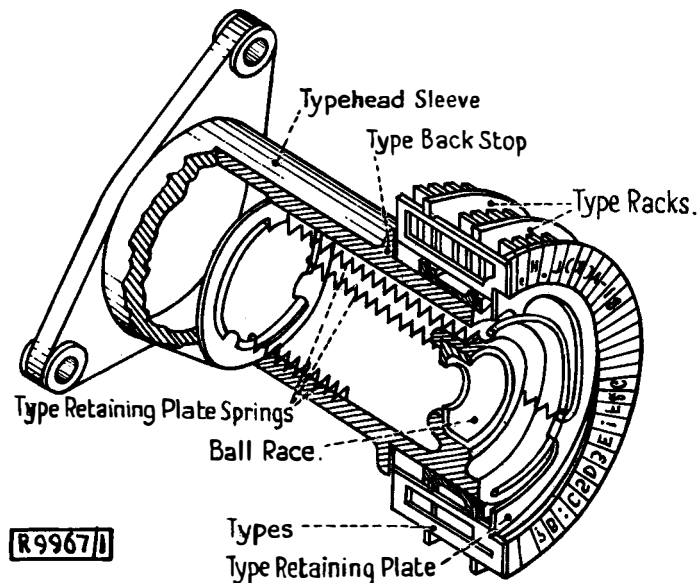

Fig. 20

stop plate of the typehead clutch. These pins are shown projecting through the stop plate in Fig. 19(b). The typehead is supported in the front, and is retained in engagement with the driving pins by means of an end thrust bearing fitted on the typehead bracket. This can be seen in Fig. 15. The type bars are accommodated in two racks, in which they are free to move parallel to the axis of the type shaft. Three spiral springs attached to a circular retaining plate maintain the types in position and return them after printing. The selected type bar is struck by the type hammer once every revolution. The forward movement of the type hammer takes place during the period when the typehead is stationary. To avoid possibility of damage to the typebars in the event of the hammer being actuated while the typehead is rotating, the type hammer head is pivoted. The hammer head is held in its normal position by the means of a flat spring, the bent end of which bears in a groove in the back of the hammer head. The printing of a character takes place during the setting up of the selection of the subsequent character, just prior to the setting of the bell cranks (Teleprinter 7B).

The New Typehead and Clutch

The two units—typehead and clutch are assembled to form one unit, both being held together on a common spindle.

The construction of the complete assembly is shown in Fig. 21. An end elevation, viewed from the typehead end, is shown in Fig. 22 (for clarity the typehead itself has not been shown).

The stop arm and the latch arm are assembled scissor fashion on the typehead spindle together with oilite friction washers the whole being sandwiched together by the stout axial compression spring. Two shock absorbing springs are inserted between the cups mounted in the two arms. When released the typehead is driven by a clutch of the conventional drum type which slips when the typehead is latched to a selected bellcrank. In the latched position the bellcrank is gripped between the stop face of the stop arm and the latch on the latch arm while the rear ends of the two arms grip a projection on the typehead spindle and thus locate the type racks. The initial shock, of the impact between the stop arm and the selected bell crank is absorbed by the shock absorbing springs. After impact the two arms make two or three oscillations about their common axis before coming to rest gripping the bell cranks.

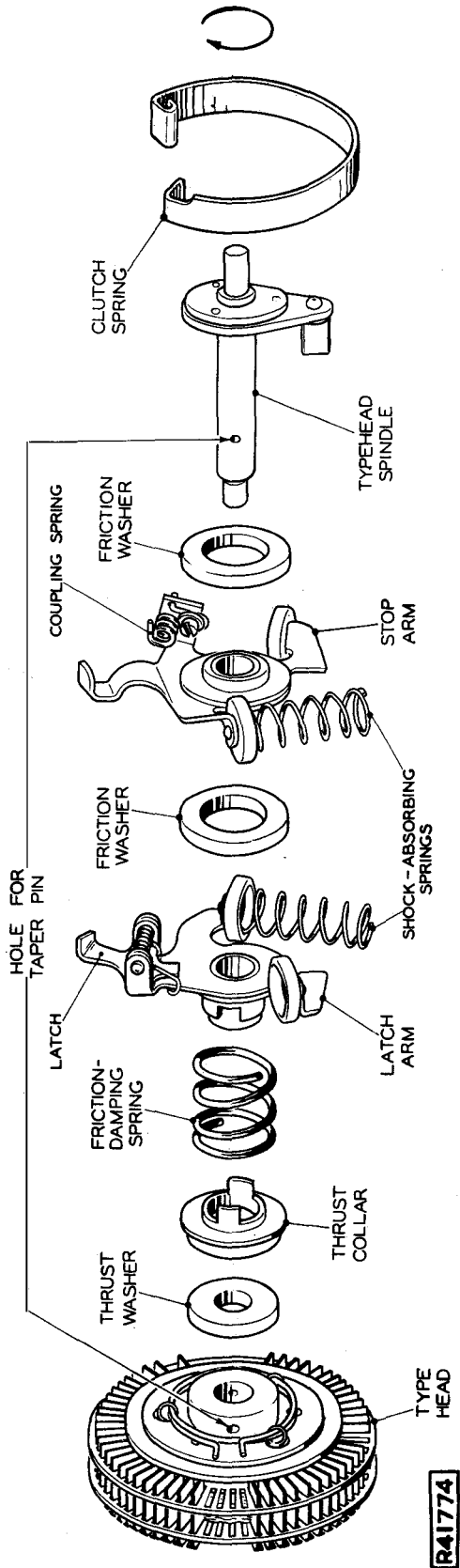

Fig. 21

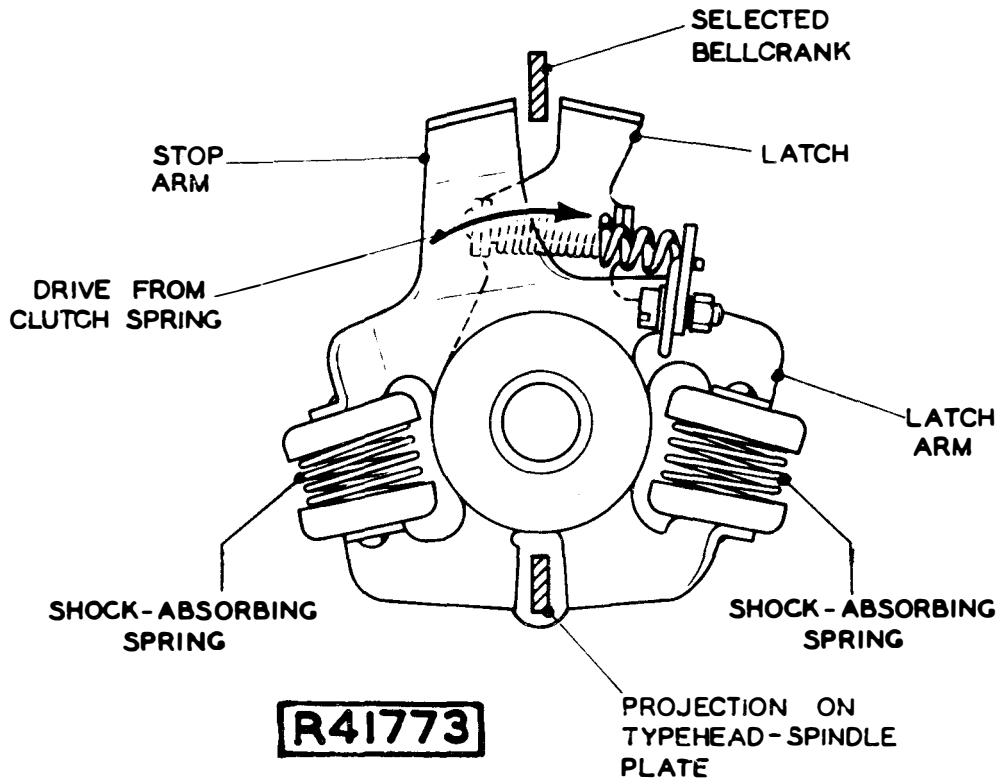

Fig. 22

RIBBON-FEED MECHANISM

The impressoon on the paper is made by means of an ink ribbon similar to a typewriter ribbon. The feed change arrangements are shown in Fig. 23. When the last turn of ribbon is unwrapped from the bobbin the weight of the feed change rod causes the bellcrank lever to protrude through a slot in the side of the bobbin. The feed change rod falls on to the feed spindle, the end of which is cut obliquely. As the spindle revolves, the inclined face on the end engages with the lower end of the feed change rod and thrusts the ribbon feed spindle to the left (or right as the case may be), thus throwing the corresponding ribbon-feed pinion out of engagement with the one crown wheel and into engagement with the other. The ribbon-feed pawl is driven by the comb-setting lever at the end of its downward movement (See Fig. 15).

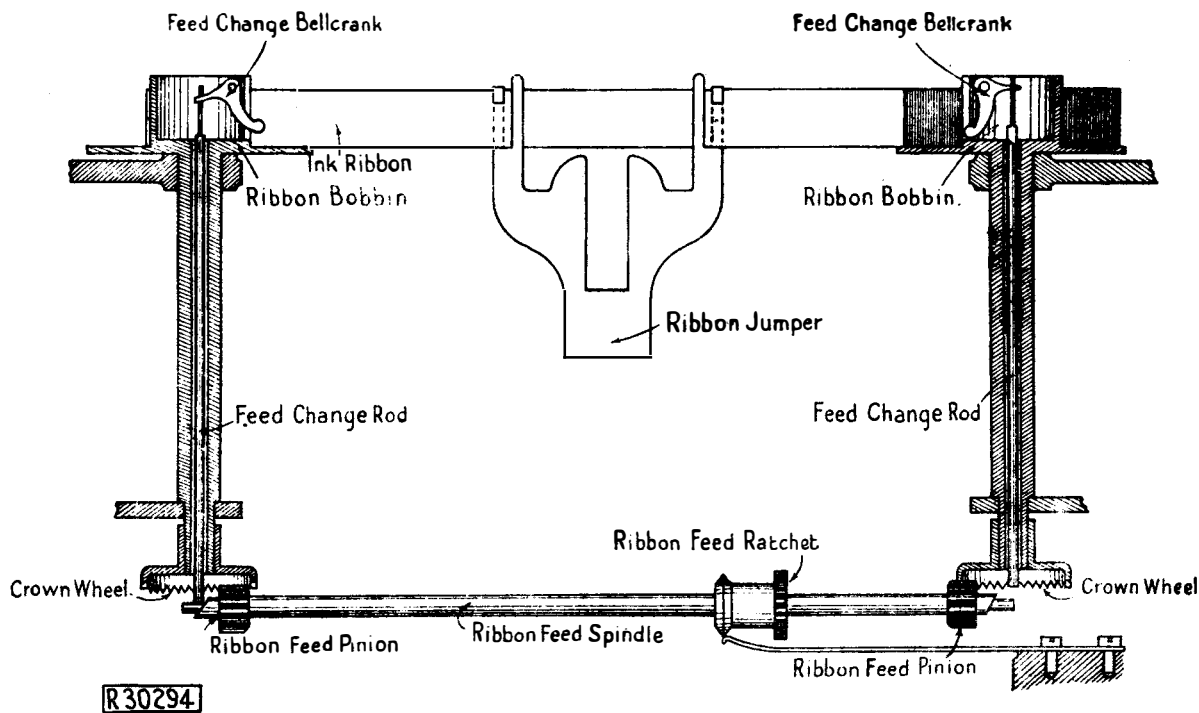

Fig. 23

To enable the printed characters in each line to be visible to the operator as they are printed, the ink ribbon is interposed between the type and the paper only when the type is struck by the hammer, and is lowered at the end of each revolution of the cam shaft. A jumper, through which the ribbon is threaded, (see Fig. 23) is free to move vertically in the typehead-bracket. A spring holds the ribbon jumper against an arm on the ribbon-jumper shaft. Motion is imparted to the shaft by the traversing lever (see Fig. 15).

CONTROL AND OPERATION OF THE CARRIAGE

The Teleprinter No. 7 is normally arranged for page printing but, if desired, can be readily converted from page to tape working. The page printing unit is, therefore, designed as a self-contained unit which can be easily removed from the machine and substituted by a tape printing unit. This calls for a special design of control levers together with what are known as functional bell cranks. Functional bellcranks are bellcranks that perform other functions than that of bringing the typehead to rest with a specific character opposite the type hammer. Fig. 24 shows these control levers and the associated functional bellcranks of which there are six, namely

- (a) figure shift bellcrank.
- (b) letter shift bellcrank.
- (c) all spacing bellcrank.
- (d) carriage return bellcrank.

(e) line feed bellcrank.

(f) bell bellcrank.

As seen, the control levers are pivoted on a common spindle and, with the exception of the throw out feed lever, are held by the means of springs so that their inner ends bear on the outer edges of the corresponding functional bellcranks.

When any one of these functional bellcranks is selected, the appropriate control lever follows the inward movement of the bellcrank thereby causing the free end of the control lever to be moved downwards. In the case of the throwout feed lever, the lever is held in its normal position by a spring so that its bent end rests on the horizontal arm of the figure and letter shift levers; thus whenever a control or a shift lever is operated the free end of the throw-out lever will be lowered. When operated, it disengages the letter feed mechanism. The bell-control lever engages on a plunger fitted in the main casting; when this plunger is depressed it closes a pair of contacts located in the base of the machine. The contacts are connected in parallel with the alarm contacts for the answer-back unit.

The 'all spacing' control lever is provided to prevent movement of the carriage in the event of the relay remaining in the spacing position. This condition arises if the marking battery becomes disconnected whilst the relay is in the spacing position.

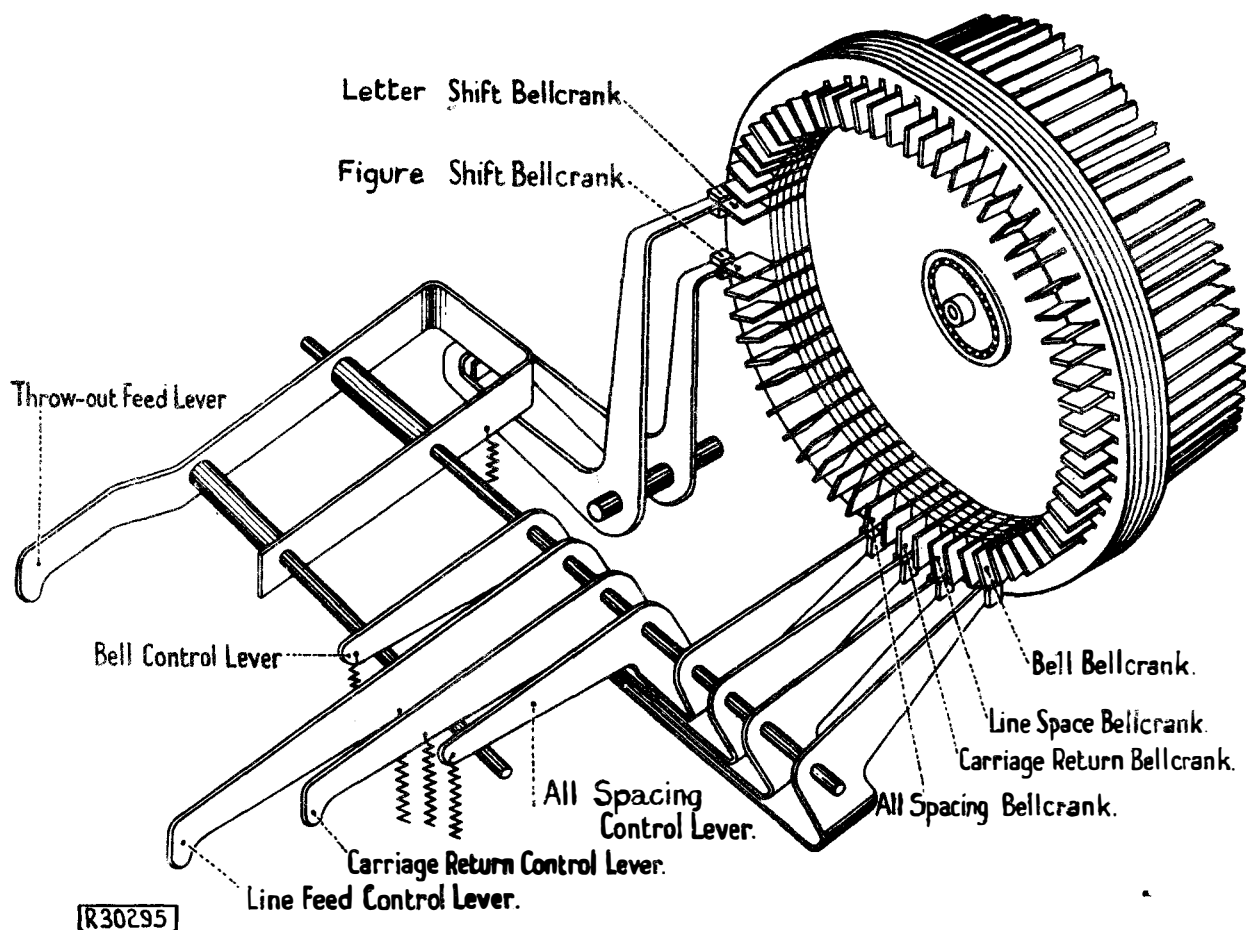

Fig. 24

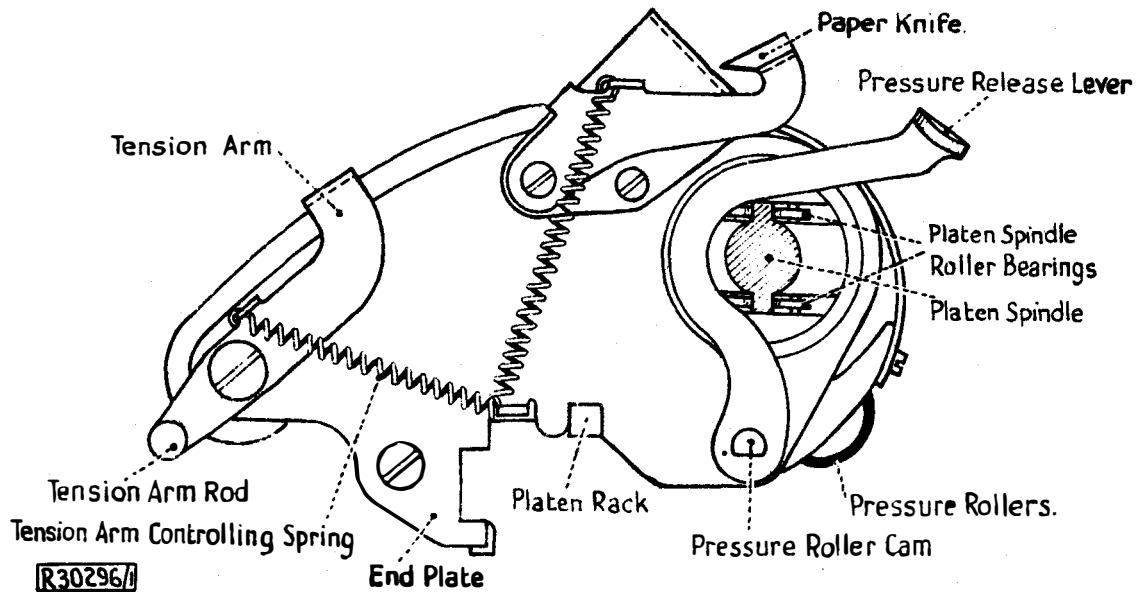

Fig. 26

The whole unit is mounted on the main base casting by means of a bar along which the grooved portion of the platen carriage frame rides.

The Letter Feed Mechanism

The letter feed mechanism (Fig. 27) propels the paper carriage, from the right to the left-hand side of the machine, one letter space as each character is printed. The letter feed mechanism drives a gear wheel which engages with the platen rack. The gear wheel is mounted on the same spindle as a spring drum to which is fixed a ratchet wheel. This ratchet is acted upon by a powerful spiral spring contained within the drum, but the action of the drum is controlled by a retention pawl. The rotation of the gear wheel, as the paper carriage is propelled to the left during the printing operation, winds up the spiral spring which is employed to return the carriage to its normal position at the end of each line of printed characters.

The motion of the clutch cross-head (which is operated from the traversing link via the carriage feed trunion; see Fig. 15), provides the necessary power for the the operation of the carriage mechanisms, and for each complete revolution of the receiving camshaft, it makes one complete oscillation as indicated by the arrows in Fig. 27. The clutch cross-head is normally at its mid-position; when operated it moves first to the left, then to the right, finally coming to rest again at its mid-position.

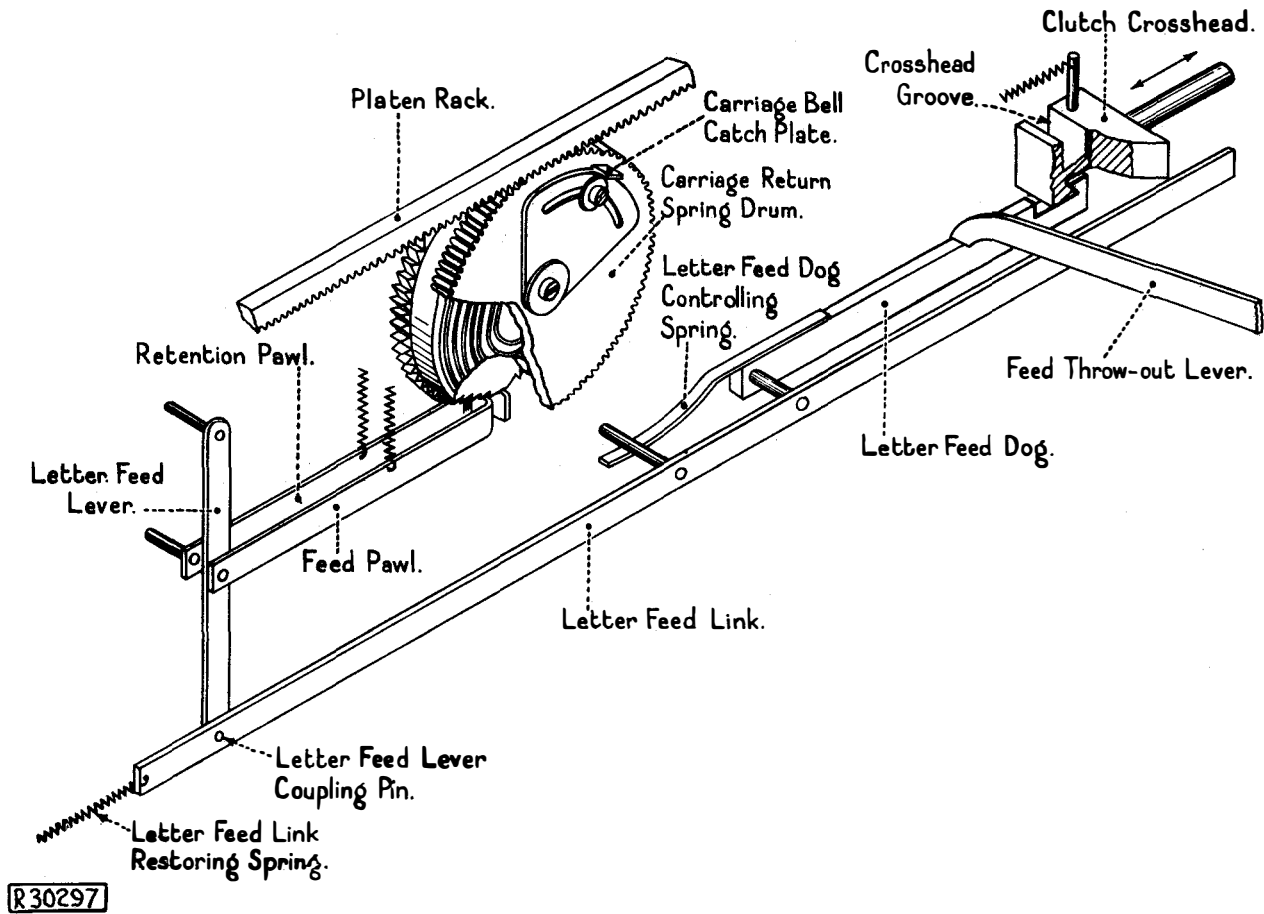

Fig. 27

The letter-feed dog is pivoted to the letter-feed link, and is normally held in engagement with a claw on the under surface of the clutch cross-head by the letter-feed dog controlling spring. The letter-feed link restoring spring is fixed at the other end of the letter-feed link, and is anchored to the main casting. While the letter-feed dog is engaged with the clutch cross-head, the tension of the link-restoring spring acting on the letter-feed link pulling it to the left, causes the link to follow the oscillating movement of the clutch cross-head.

The letter-feed lever is pivoted at its upper end, so that the motion of the feed link is transmitted to the feed pawl.

It should be noted that it is not necessary for the letter feed mechanism to operate when any of the following keys are depressed:-

- (i) Letter Shift
- (ii) Figure Shift
- (iii) Line Feed
- (iv) Carriage Return.

Their respective control levers are therefore arranged to operate the feed throw-out lever which when operated, depresses the letter feed dog and disengages it from the clutch cross-head.

Carriage-Return Mechanism (Fig. 28)

This mechanism returns the paper carriage from the left-hand to the right-hand side of the machine at the end of a line. It is normally returned mechanically but can be returned manually by depressing the carriage-return key. The normal operation is as follows:- When a "carriage-return" signal is received by the carriage-return control lever, acting on the carriage-return dog, which is normally held out of engagement with the clutch cross-head by the carriage-return dog controlling spring, raises the dog into engagement with the clutch cross-head. The carriage return dog is pivoted to the carriage release link, and the spring ensures that the dog and the link will follow the movement of the clutch cross-head.

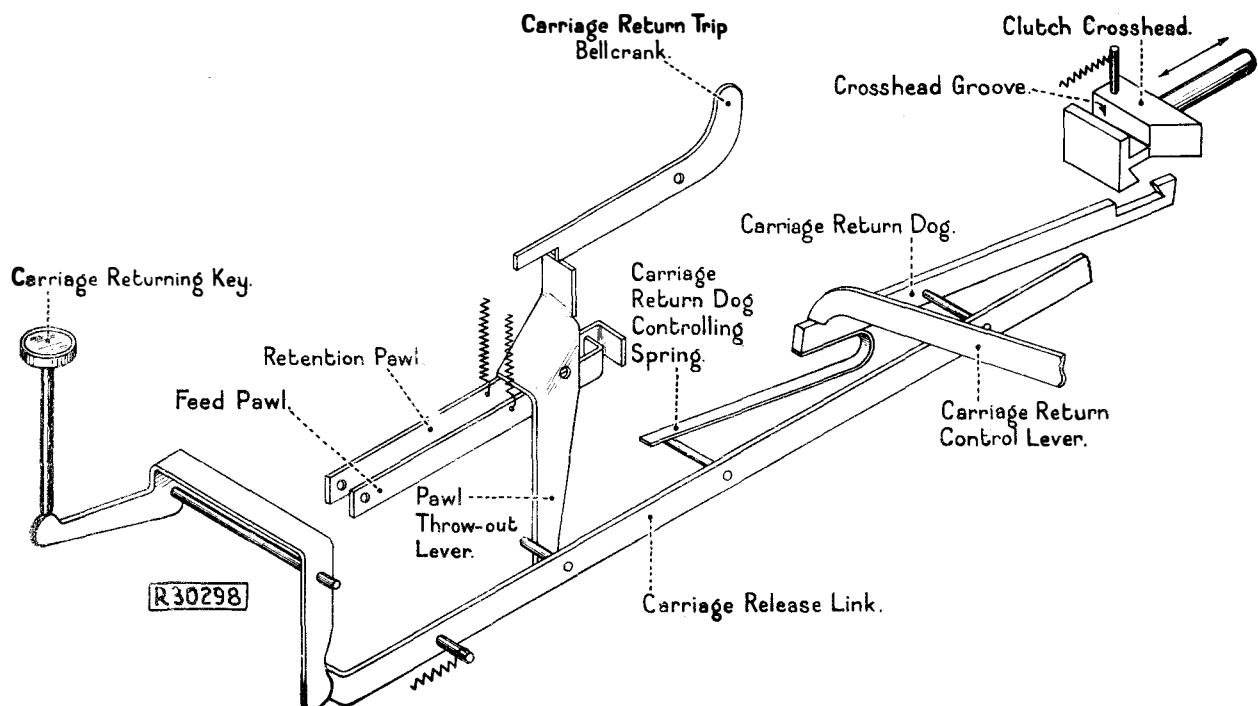

Fig. 28

as in the case of the letter-feed dog. The pawl throw-out lever is pivoted at its upper end, and at its lower end it engages with the letter-feed lever coupling pin, fixed on the carriage-release link. As the clutch cross-head moves to the right, the bottom end of the throw-out lever is deflected, and the upper end depresses the feed and retention pawls, disengaging them from the carriage spring drum. This permits the carriage spring drum to rotate and return the paper carriage. It is arranged that the pawl throw-out lever cannot release until the carriage has completely returned.

Carriage Air Piston (Fig. 29)

To minimize the shock of impact as the paper carriage is returned, a shock absorber is fitted at the end of the platen spindle. This consists of a small piston, which enters a cylinder situated inside and at the right-hand end of the platen. A small air-outlet is drilled through the piston, to permit the escape of air from the cylinder. The speed at which air is permitted to escape from the cylinder through the air-outlet determines the degree of cushioning obtained with the shock absorber, and also affects the time taken to complete the return of the carriage. An adjustment for varying the degree of shock absorption is provided by the valve plate, which is fitted at the end of the piston. The valve plate is slightly elliptical, and is free to turn about the platen spindle with the limits of the adjusting slot. As the valve plate is turned, the extent to which the air outlet is covered is varied. The valve plate can be locked in any desired position by the locking screw, access to which is gained through a hole in the carriage bearing bracket after removing the knob on the end of the platen spindle. The valve plate extension projects from the end of the piston, and provides a means of adjusting the valve plate.

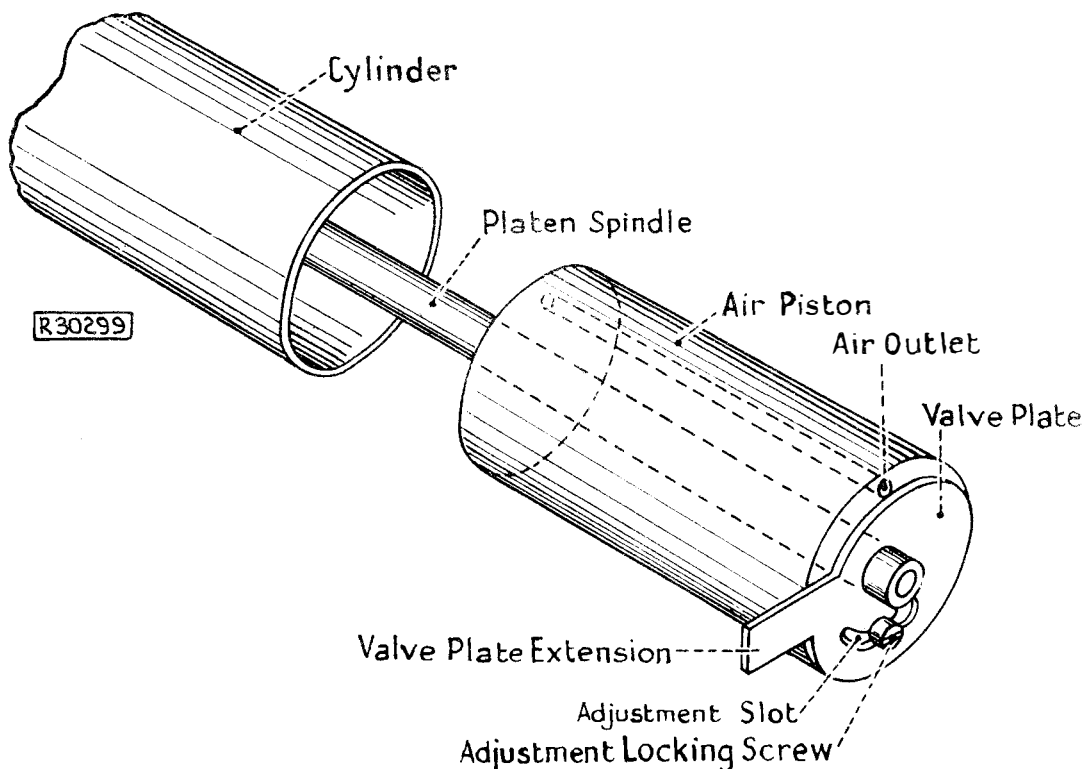

Fig. 29

The line-feed mechanism (Fig. 30) rotates the platen on the completion of each line in readiness for the next line. It is operated by the line-feed control lever, which causes the line-feed dog to engage with the clutch cross-head.

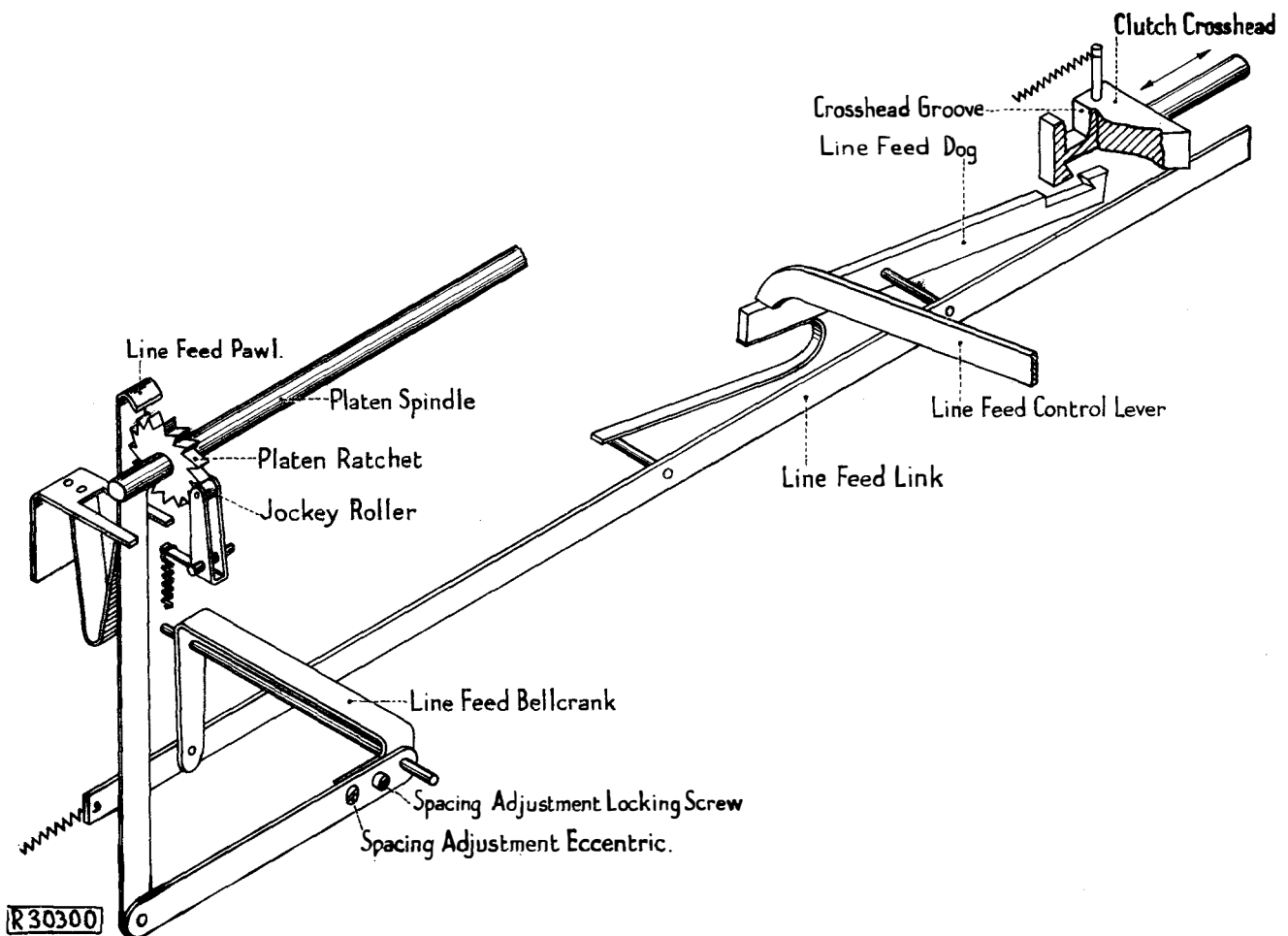

Fig. 30

The Carriage Bell

In order to indicate that the carriage is approaching the end of the line the carriage bell catch plate (Fig. 27) engages with a pawl and causes a hammer to strike a bell. It is adjusted so that the bell rings at a point 15 characters from the end of the line.

THE FIGURE AND LETTER SHIFT FACILITY

The five unit code provides for $2^5 = 32$ different combinations of space and mark elements. As will be appreciated this is insufficient for the necessary range of characters and a "shift facility" is introduced; this is controlled by the depression of the "letters" or "figures" keys.

The depression of either of these keys causes the rotation of a six combination comb in the receiving mechanism of the receiving teleprinter. This comb is called a shift comb. Unlike the five combination combs the shift comb has no extension and is not therefore operated by the selecting mechanism in the ordinary way. Fig. 31 shows an end-on view, looking along the shaft.

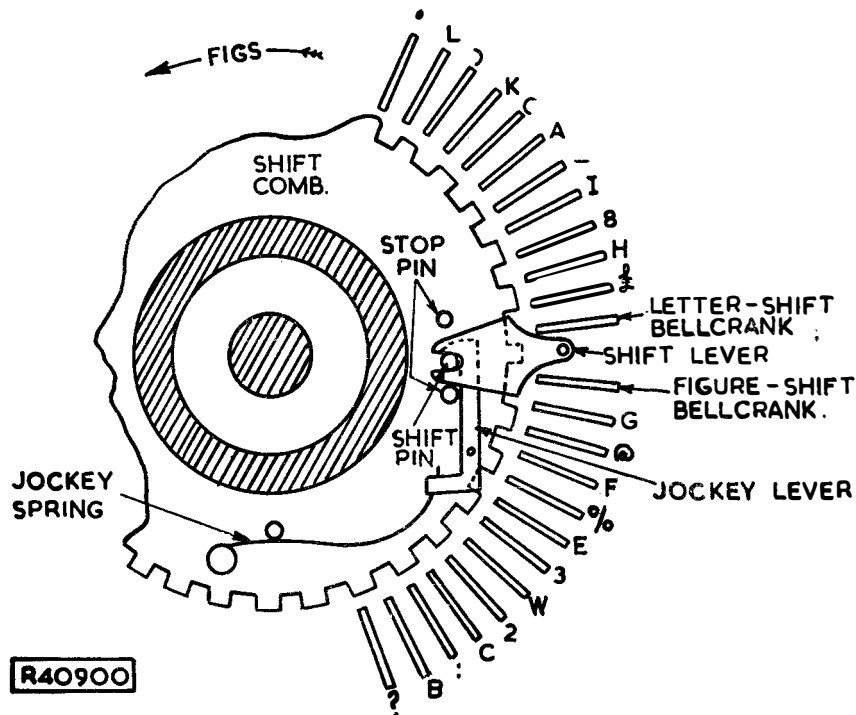

Fig. 31

It will be seen that the shift comb has indentations along its periphery all equally spaced and the distance apart, or pitch, of the indentations being twice the basic pitch of those on the receiving combs. The shift comb is free to move on the drum similar to the other combs and its movement is limited to the distance of one bellcrank spacing. Thus whichever position the shift comb occupies, it permits only one of a pair of adjacent bellcranks to be drawn inwards into the channel prepared by the selecting combs which are moved in accordance with a signal combination. Therefore, for each combination received, only one bellcrank is operated, the position of the shift comb determining whether a bellcrank in the "letters" or "figures" group is brought into action.

The shift comb is operated by the shift comb lever (as shown in Fig. 31), this is mounted on a pivot on the bellcrank rack, in a position such that it can be operated by an inward pressure on either of its shoulders by the figure shift or letter shift bellcrank. The lever is held firmly in either of its two operated positions by means of the toggle action of the shift comb lever spring. Thus when the shift comb has been set for "letters" all characters printed thereafter will be in the letter case until the receipt of a figure shift combination causes the figure shift bellcrank to be operated; the shift comb is then moved to its alternative position after which only bellcranks in the "figures" group can be selected until the letter shift combination is again received. The operation of the appropriate bellcrank controls, of course, the corresponding positioning of the typehead.

ANSWER BACK UNIT

The answer-back unit is provided to enable a teleprinter subscriber to ascertain that he (or she) is connected to the correct machine and that that machine is serviceable. The operation of the answer back unit thus gives an identifying signal for that particular teleprinter. The unit is brought into action on a receiving teleprinter by depressing the key labelled "who are you" on the teleprinter at the sending end. The "who are you" key is a secondary character to the letter D. The arrangement is illustrated diagrammatically in Fig. 32. The answer-back driving gear wheel is driven continuously. The answer-back drum spindle is coupled to the gear wheel by a friction clutch but is prevented from rotating by the answer back detent.

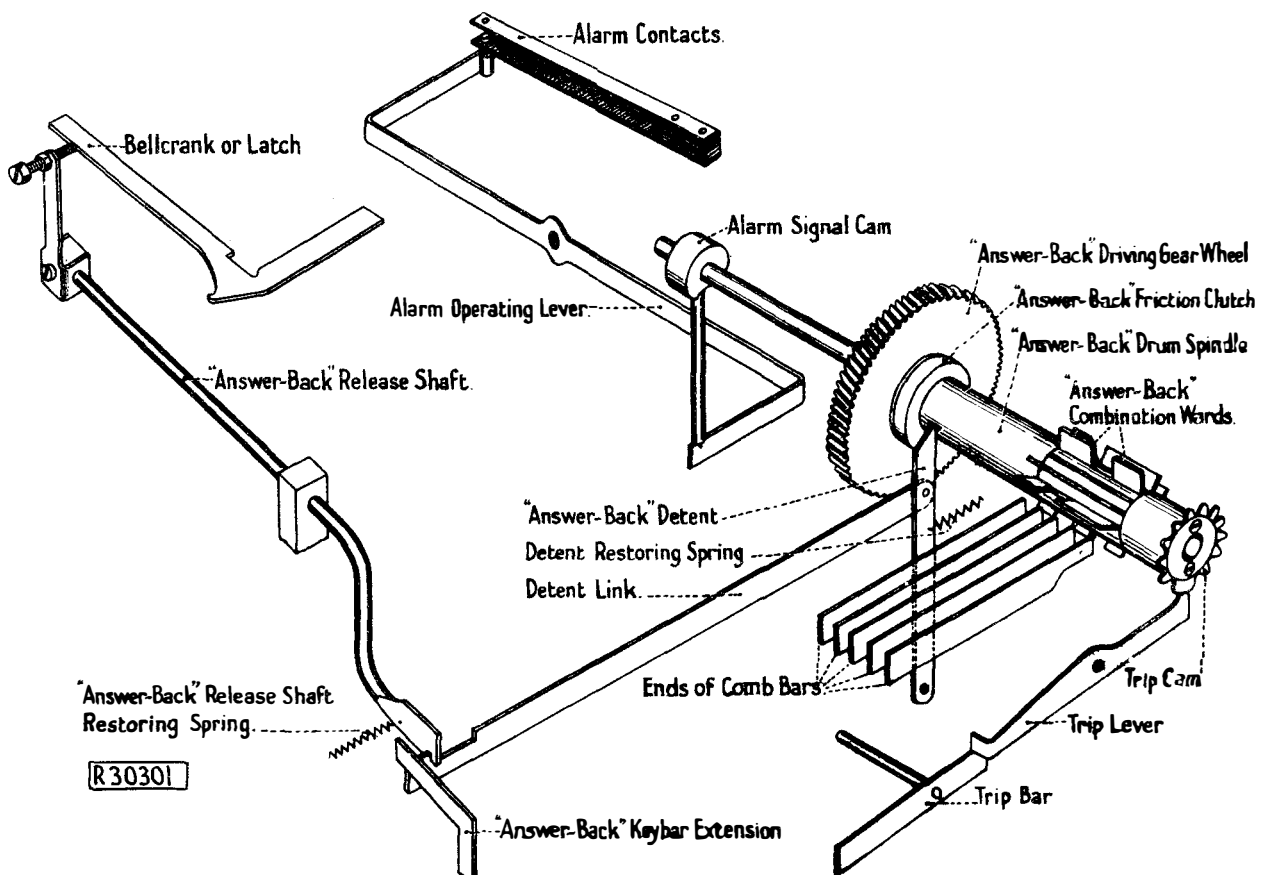

Fig. 32
33.

On the receipt of the answer-back combination the latch moves inwards, allowing the answer-back release shaft to rotate under the action of its spring. In doing so it moves the detent link to the left. The detent is released and the answer-back drum spindle commences to rotate.

The trip cam has twenty equally-spaced teeth, one of which is double the pitch of the remainder, and is fixed on the end of the answer-back drum spindle so that the teeth are at 90° relative to their corresponding projections or wards on the drum spindle. A trip lever is pivoted so that one end engages with the trip cam and the other with the trip bar. As the drum spindle revolves, the trip lever depresses the trip bar as the projections on the cam pass the comb bars; thus, the transmitting cam is tripped for every signal combination transmitted by the answer-back unit. The comb bars, instead of being pre-set by the depression of keys as in normal transmission, are controlled by the combination predetermined by the position of the projections or wards on the answer-back unit drum spindle. The projections on the shaft are so arranged that, when the answer-back unit is at rest no projection is situated opposite the ends of the comb bars; therefore the displacement of the comb bars, as a result of the normal keyboard operation, is unaffected.

The alarm-signal cam also rotates with the answer-back drum spindle and can be arranged to give an audible or visual signal, indicating that a message is about to be received.

THE AUTOMATIC MOTOR SWITCH

The automatic motor switch provides a facility which eliminates the necessity for the continuous attendance of an operator, at the teleprinter. It will be appreciated that with no messages being passed, the motors on the teleprinters will still be running and if this period of no traffic is prolonged the noise of the motor becomes a nuisance and an unnecessary expense in view of the current taken from the mains and wear of bearings, brushes etc. A device is therefore fitted which, after a period of inactivity disconnects the circuit of the motor. The motor circuit is immediately reconnected on the receipt of the start signal of the next character which is received. There is therefore no mutilation of messages.

The device is often referred to as an automatic start-stop switch but it should be emphasized that it has no connexion with the start-stop principle of telegraphy.

The controlling mechanism and switch are shown diagrammatically in Fig. 33.

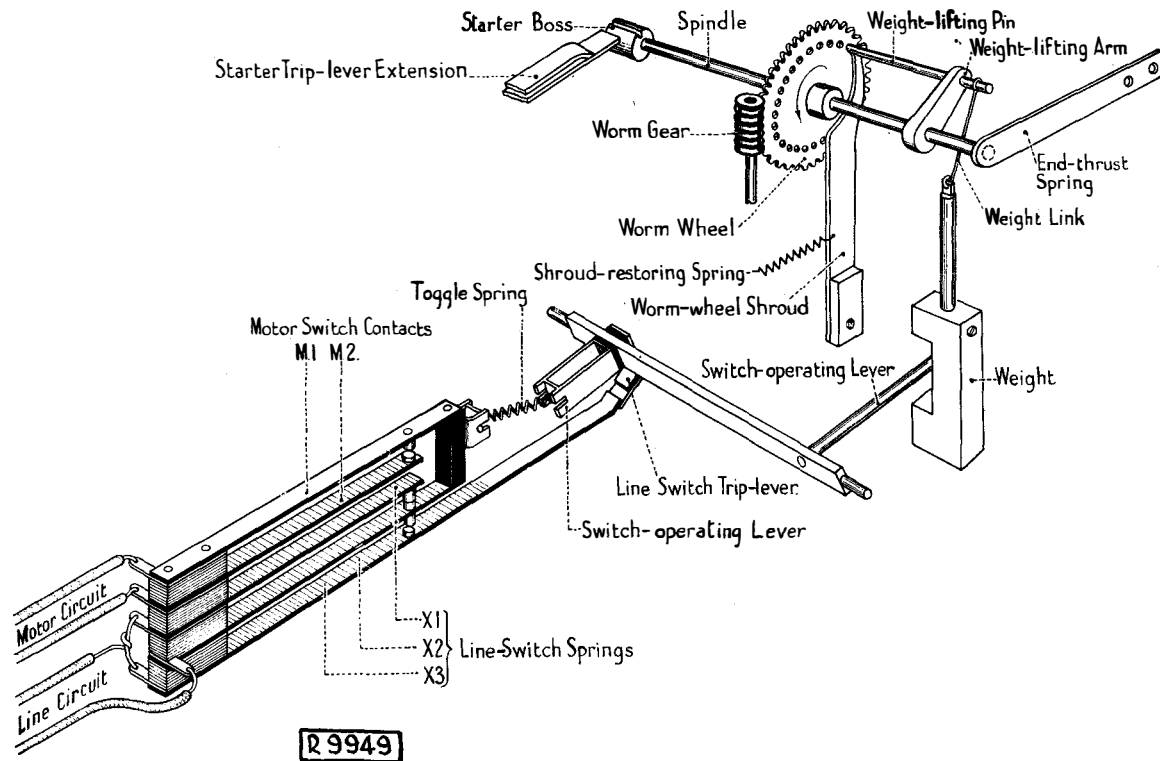

Fig. 33

The starter spindle is free to move longitudinally through the worm wheel; one end of the spindle carries the starter boss mounted near the extension of the starter trip lever. This lever is coupled to the electromagnet armature. The weight lifting arm is fixed upon the spindle at the other end and is coupled by a link to the weight. Fixed at the end of the weight lifting arm is a pin; this is normally held in engagement in one of a series of holes in the worm wheel by the inward pressure of the end thrust spring which acts upon the spindle. The sketch shows the mechanism in the position when the motor is not running. Upon the receipt of the start signal of a code combination the armature moves to spacing and so operates the trip lever which moves the spindle longitudinally through the worm wheel. By this means, the pin is disengaged from the worm wheel and the weight is allowed to drop forcibly on the switch operating lever; this closes the contacts M_1 and M_2 which complete the power supply to the motor. The function of the worm wheel shroud is to prevent the weight lifting pin re-engaging with the worm wheel during the time the weight is falling to its lowest position, i.e. to the left of the bottom of the worm wheel shroud. Further signals now maintain the mechanism in this position by continuously disengaging the pin from the holes in the worm wheel. If no signals are received, the pin engages in one of the holes in the worm wheel due to the pressure of the thrust spring. The worm wheel which is continuously rotating raises the weight lifting arm and weight. This weight engages the switch operating lever which in turn causes the switch to operate and break the contacts M_1 and M_2 , thus disconnecting the power supply from the motor. The motor is switched off after a period of approximately 90 seconds without signals. The worm wheel shroud is displaced by lifting the pin as the weight is lifted, but is restored to its normal position by the shroud spring just before the motor comes to rest. The line switch springs X1, X2, X3 in the sketch may be ignored as they are no longer in use.

LOCAL RECORD

A local record is usually provided on the Teleprinter No. 7 via the send receive switch which is operated as soon as the transmitter cam commences to rotate. This action places the teleprinter receiving magnet and a 4000Ω resistor in parallel with the line itself and thus signals sent out by the transmitter will operate the local receiver magnet in a similar manner to the distant receiver (assuming normal working conditions). Fig. 34 shows the principle of the circuitry involved.

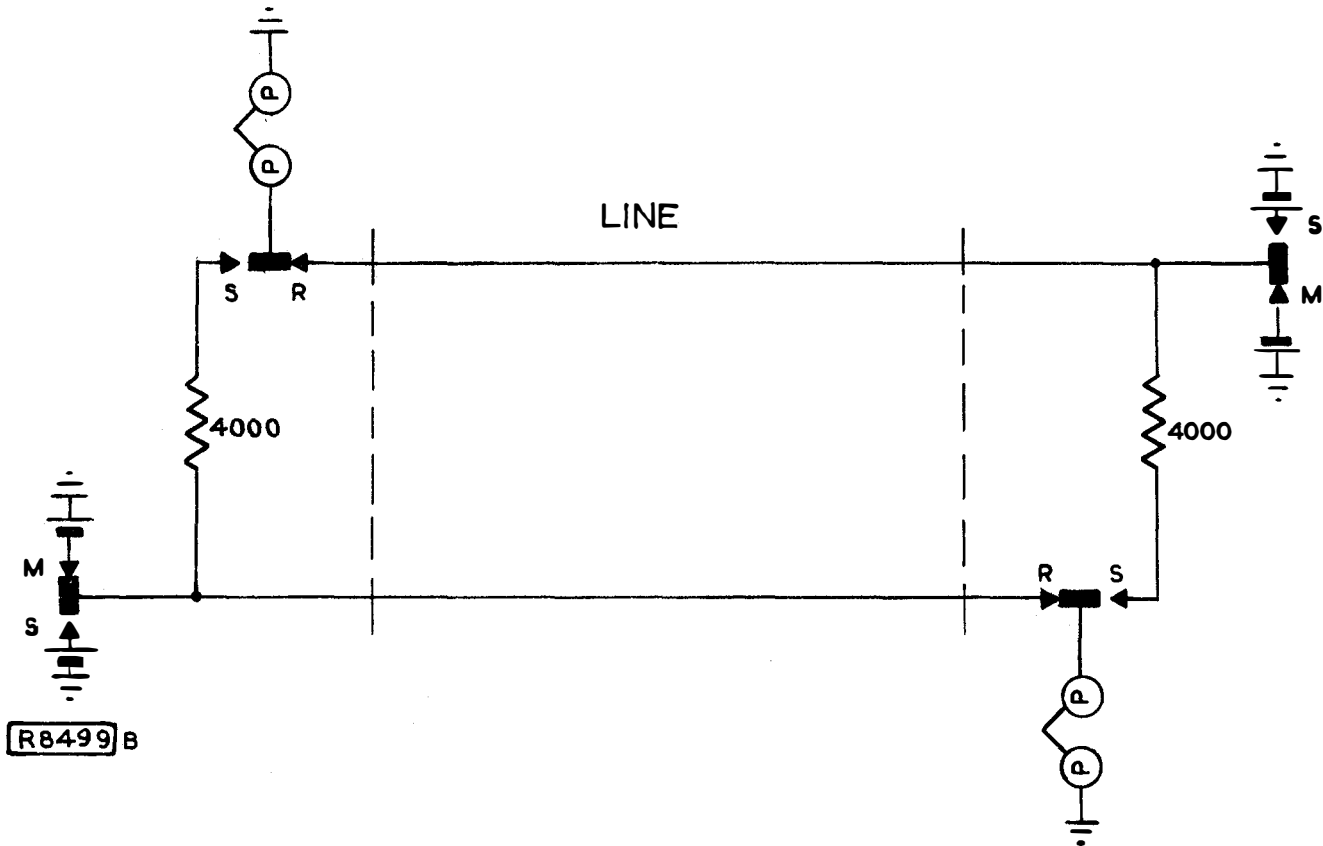

Fig. 34

The 4000Ω spool resistor is fitted in the base of the machine for a teleprinter No. 7B, whilst for Teleprinters No. 7D and 7E the 4000Ω spool is fitted underneath the equipment table (or in the signalling unit).

THE OVERLAP CAM UNITINTRODUCTION

The overlap cam unit, which is used on the Teleprinter No. 7E, has been designed with three major aims in view namely:-

- (1) Immediate printing. Each character is printed immediately after the corresponding key is depressed and not after the depression of the next key.
- (2) Increased receiver margin. Previous receiving cam units have satisfied the C.C.I.T.T. requirement of $\pm 35\%$ for new machines. The overlap cam unit gives a guaranteed minimum margin of $\pm 40\%$. This greater operating tolerance ensures maximum reliability under the most adverse and varied conditions.
- (3) Longer life of parts and reduced maintenance costs. Improvements have been made to the design of parts and to the method of lubrication to obtain a higher standard of operation and to reduce maintenance costs.

These objectives have been achieved by the introduction of three features which involve departing from the basic principles of design of previous receiving-cam units:-

- (a) Four cams (pilot, selector, comb setting and printing) now replace the former single cam or two cams in the case of the orientation cam unit. Each cam is released by the preceding cam except for the pilot cam which is released by the electromagnet.
- (b) Friction clutches are used to drive the pilot and selector cams.
- (c) The introduction of the principle of 'chopper' selection.

Fig. 35 shows a timing diagram from which it will be seen that the operation cycles of the various cams overlap. Each cam completes its rotations in 130 ms with the teleprinter running at its correct speed.

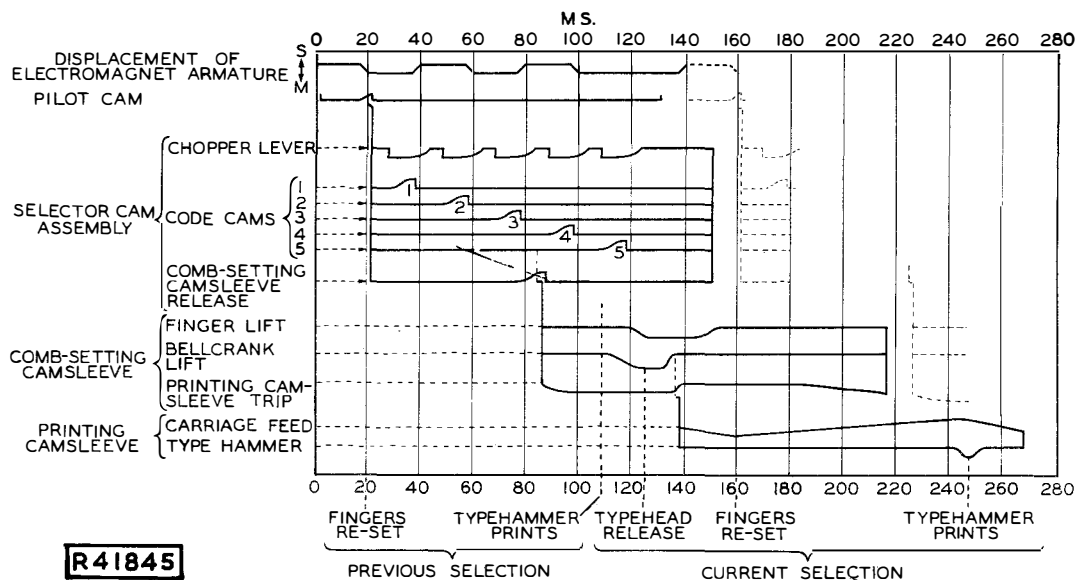

Fig. 35

CAM FUNCTIONS

(a) The orientation pilot cam determines the instant at which the selector cam starts to rotate and hence the instants at which the incoming signal elements are read. The pilot cam is driven by a friction clutch with a pick up time of a fraction of a second which is constant and can be neglected.

(b) The selector cam is also driven by a friction clutch with a small and constant pick up time. This cam can be said to receive and interpret or 'read' the five signal code elements of the incoming signal and during the fourth element, releases the comb-setting cam.

(c) The comb-setting cam is actuated by a ratchet and pawl clutch which will introduce a small variable pick-up time. This however, is unimportant and has not been indicated on the timing diagram. The comb-setting camsleeve raises the bellcranks of the combination head and then raises the comb-setting fingers already set in accordance with the code elements of the incoming signal, to locate the receiving combs of the combination head. The bellcranks and the fingers are then lowered, in that order, and the printing camsleeve released. This camsleeve also actuates the ribbon feed ratchet pawl.

(d) The printing camsleeve, driven by a similar ratchet and pawl clutch, causes the carriage to feed, and after an interval of time, operates the typehammer to print the selected character. This camsleeve also controls the resetting of the comb-setting fingers and the ribbon lift.

ORIENTATION CAM MECHANISM

This mechanism is identical to that used on the Teleprinter No. 11 and is shown in Fig. 36.

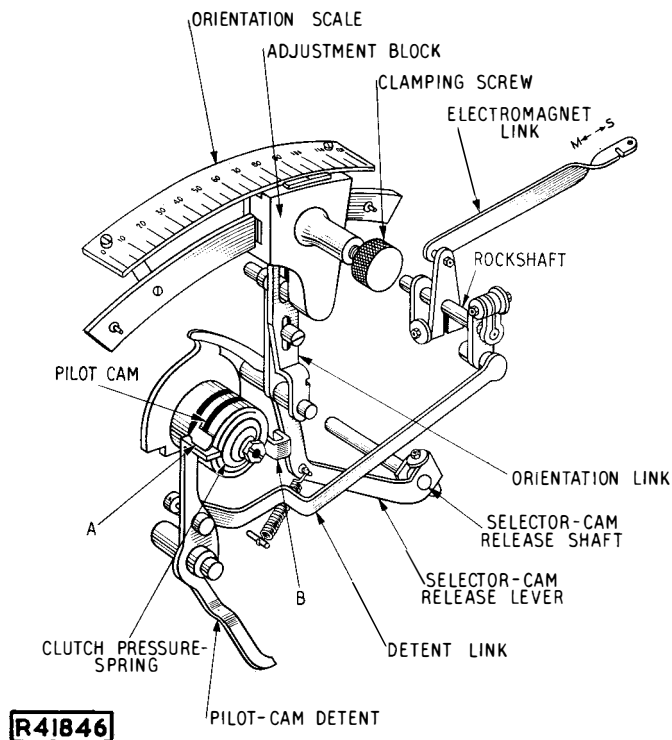

Fig. 36
38.

Projection A of the cam is held against the pilot cam detent in the rest position. The initial spacing movement of the electromagnet armature at the commencement of the start signal element is transmitted *via* the electromagnet link to the rockshaft and via the detent to the pilot-cam detent. This releases the detent to permit the pilot cam to rotate.

After a partial revolution of the cam, projection B comes into contact with the roller at the end of the orientation link. This link is moved outwards and in turn moves the spring-loaded release lever for the selector cam assembly away from its stop. The release lever rotates the selector cam release shaft through a small angle to release the selector cam assembly.

During the stop signal, the pilot-cam detent is moved to the marking position and arrests the pilot cam after one revolution. The cam then remains at rest until the next start signal is received.

SELECTION MECHANISM

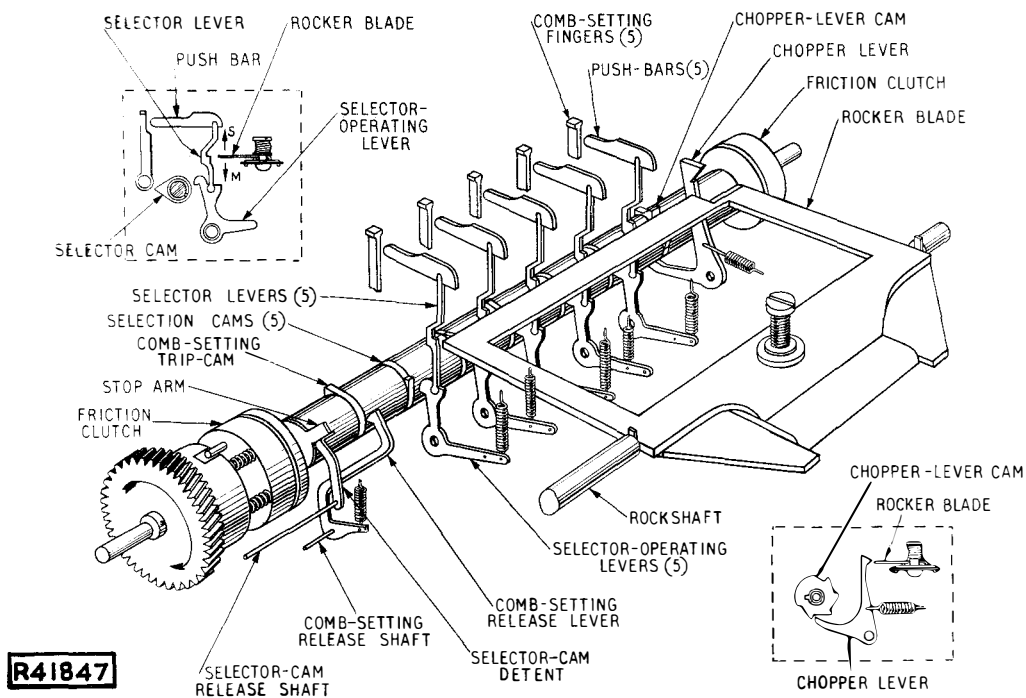

Fig. 37

Fig. 37 shows a diagram of the selector-cam assembly. It comprises, essentially, a stop arm, a comb setting trip cam, five selection cams and a chopper lever cam. The whole assembly is mounted on a driving spindle which is geared by a 1:1 gearing to the main driving spindle of the overlap unit.

Selection is performed by the rocker blade in conjunction with five spring-loaded selector operating levers, five selector levers and five push bars (these are all labelled in Fig. 37) which jointly displace the five comb setting fingers in accordance with the incoming signal. The rocker blade is a flat plate cut away as much as possible to reduce weight and having an accurately ground straight-edge which is presented to the selector levers. The blade is lightly clamped to the rockshaft by a compression spring and shouldered screw so that it normally follows the motion of the rockshaft (due to the marking and spacing displacements of the electromagnet armature) but can be held up or down without damage. At one end opposite the chopper lever the blade is formed into a knife edge.

The selector levers each have a square step, the vertical side being opposite the rocker blade when the electromagnet armature is against the marking stop. In the spacing condition the blade just clears the horizontal side of the step (see Fig. 37). The projections of the five selector cams are arranged to begin to move the five selector operating levers in sequence at approximately 8, 28, 48, 68 and 88 ms from the instant of release of the cam assembly i.e. just before the mid points of the five code elements if the orientation adjustment block is set at 60.

THE CHOPPER LEVER CAM

Immediately each selector operating lever starts to move, the chopper lever cam releases the chopper lever. The purpose of this is to prevent any further movement of the rocker blade. The knife edge of the chopper lever engages with the knife edge of the rocker blade and holds the blade either in the marking position or up in the spacing position. The blade is held in position for some 8 ms while the signal element is "read". If the signal polarity changes whilst the rocker blade is locked, the permissive clamping of the blade allows the electromagnet armature and rockshaft to move. Then on withdrawal of the chopper lever the blade is free to take up its new position before the selection of the new signal element.

Each selector lever pivots about the edge of the rocker blade if this is in the marking position so that as the lower end of the lever moves under the action of its selector-operating lever, the top end displaces the associated push bar and comb setting finger. With the blade in the spacing position this pivoting action cannot occur and the finger is not displaced.

COMB-SETTING CAMSLEEVE

Just before the selection of the fourth code element the comb setting trip cam actuates the comb setting release lever. The pawl abutment of the comb-setting camsleeve is withdrawn and on engagement of the pawls the camsleeve starts to rotate. The pawl abutment is then restored to the rest position in readiness to re-engage the pawls when the cam-sleeve has completed its rotation.

The comb-setting camsleeve has two cam tracks which operate the bellcrank lifting lever and the comb setting lever. The camsleeve has also a radial cam (printing release cam) associated with a retention lever which in addition to retaining the camsleeve in the rest position after completing its revolution also operates the printing-release lever. As will be seen from the timing diagram of Fig. 35 the bellcranks begin to rise just after the mid-point of the fifth signal element and are fully raised about 10 ms later when the comb-setting lever begins to raise the comb setting fingers. When the fingers are fully raised and the receiving combs of the combination head set for the new selection, the bellcranks are lowered, followed by the comb-setting fingers.

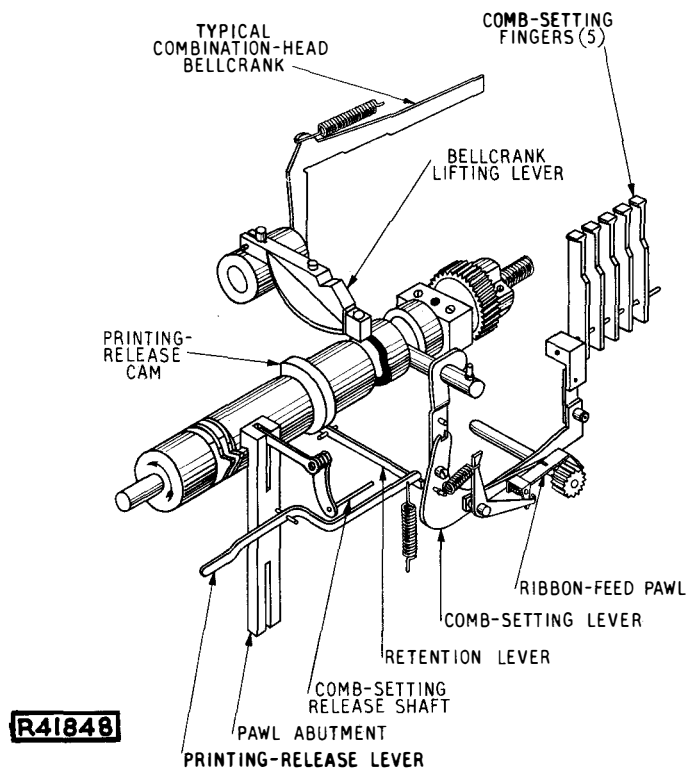

Fig. 38

On completion of one revolution of the camsleeve the pawls are de-clutched by the pawl abutment and the camsleeve is held on its rest position by a retention roller on the end of the retention lever.

PRINTING CAMSLEEVE

The printing-release cam actuates the printing release lever at approximately 140 ms (see Fig. 35) and releases the printing camsleeve by withdrawing its pawl abutment. Fig. 39 shows the printing camsleeve and associated equipment. The two cam tracks on the printing camsleeve actuate the traversing lever and the typehammer lever. The end of the traversing lever is connected by the traversing link to the carriage feed lever which actuates the carriage feed mechanism of the printing attachment in the normal way. Mounted on the traversing link is the finger resetting trip-bellcrank. Immediately following release of the camsleeve the traversing link is moved towards the front of the teleprinter i.e. to the left in Fig. 39. The operating edge of the finger-resetting trip-bellcrank engages with the finger-resetting lever, which displaces the finger resetting link, thus restoring to the unoperated position all those comb-setting fingers which have been set forward.

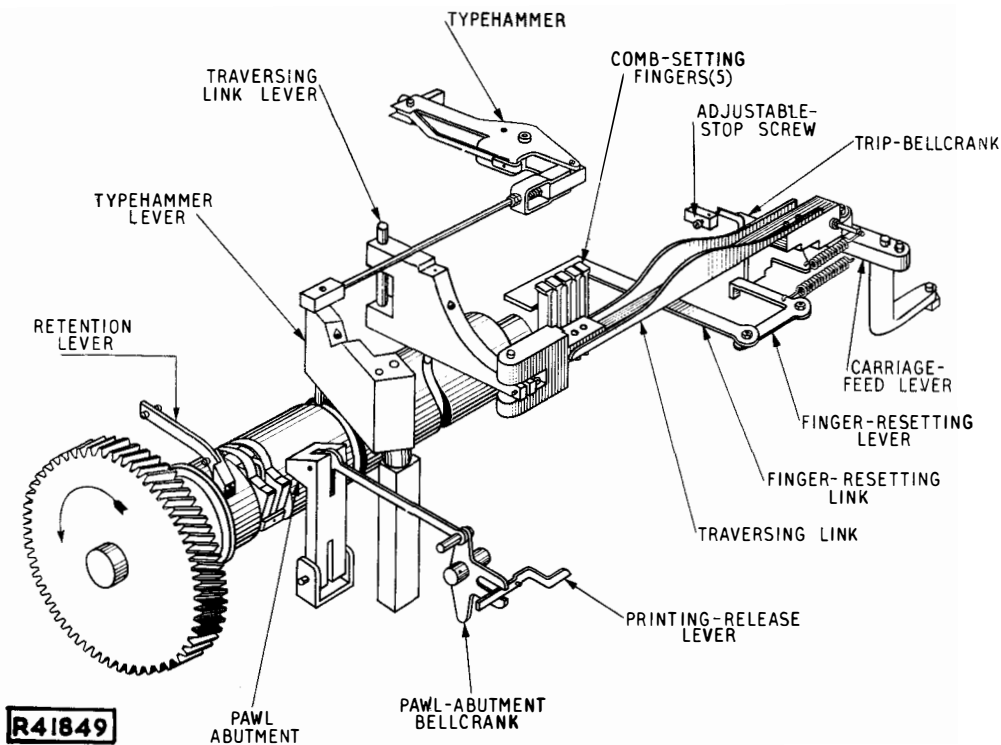

Fig. 39

When resetting is complete, the tail of the trip bellcrank engages with the adjustable-stop screw causing the operating edge to slip out of contact with the resetting lever, thus allowing it to restore under the action of its spring, taking the resetting link with it. The resetting of the comb setting fingers is timed to be complete at 160 ms from the commencement of the start signal.

The typehammer operation occurs at approximately 245 ms i.e. about 125 ms after the typehead is released. At the end of a revolution the pawls are de-clutched by the pawl abutment and the camsleeve is held in its rest position by a retention lever.

PHASING OF THE DIFFERENT CAM CYCLES

The timings of the various operations of the four cam cycles are arranged so that the machine will function correctly under the most onerous conditions. Referring to the timing diagram (Fig. 35), it will be observed that the comb setting fingers are reset from the previous selection not later than 20 ms after the commencement of the start signal element i.e. at least 10 ms before the first code cam operation. Similarly the previously selected character is printed not later than 110 ms., i.e. before the bellcranks are raised by the comb-setting camsleeve and the typehead is released to rotate and latch on the bellcrank selected in accordance with the current incoming signals.

It will be realized that when receiving undistorted signals each cam is at rest for at least 10 ms even at the maximum speed of operation, since the time of rotation is 130 ms and the transmitted character duration with 7-unit signals is 140 ms. The rest period will be reduced with distorted signals, but will still be adequate.

The fitting of the overlap principle cam unit increases the mechanical loading of the machine and a more powerful motor is therefore required on machines so equipped.

END