

TRANSMITTERS, AUTOMATIC, No. 2A AND 2D

Description and Operation

★[NOTE: As this Instruction has been completely revised, individual paragraphs have not been "starred"]

1. Scope of Instruction.—This Instruction describes Transmitters, Automatic, Nos. 2A and 2D and explains fully the method of operation of Auto. Transmitters No. 2D. The various features of the No. 2A machine which are common also to the No. 1B and No. 1C machines are not fully described in this Instruction because necessary information is contained in J 1001 and J 1002, to which reference should be made. Adjustments are described in J 5011 and details of spare parts and the procedure for obtaining them are given in the series of Instructions J 5301 to J 5309.

2. General.—Transmitters, Automatic, No. 2A and 2D both operate with standard $\frac{1}{8}$ in. width, 5-unit, fully-perforated or "chadless" tape, as described in J 1001 and J 1002, respectively. The machines differ, however, in the following respects:—

(a) *The No. 2A machine* consists essentially of a transmitter head identical with that of a No. 1C machine, [i.e. a No. 1B (Mk. II) transmitter head fitted with a tape-retaining assembly suitable for use with "chadless" tape], mounted on an improved main-base unit and driven from a 1500 r.p.m. motor. A lined cover is provided to totally enclose the motor and tape-control unit.

(b) *The No. 2D machine* is almost identical with a No. 2A machine in external appearance but differs from it in the following respects:—

- (i) The transmitter head incorporates a striker-type transmitting mechanism.
 - (ii) The tape-feed mechanism provides step-by-step feeding and the tape remains stationary while it is being sensed by the peckers.
- (c) The pecker lever springs are individually adjustable.

(d) The driving coupling between the tape-control unit and the transmitter head is of the "Oldham" type and uses a coupling disk as on the Teleprinter No. 7.

(e) A stroboscopic disk is not provided on the transmitter head.

(f) Cam rollers are fitted on the retention and "send-receive" switch levers.

(g) The machine is finished in grey hammer-finish enamel.

The machine, illustrated in Figs. 1 and 2, is finished in the grey hammer enamel, which is standard for No. 2D machines; No. 2A machines are generally finished in black crackle enamel.

The overall dimensions are approximately the

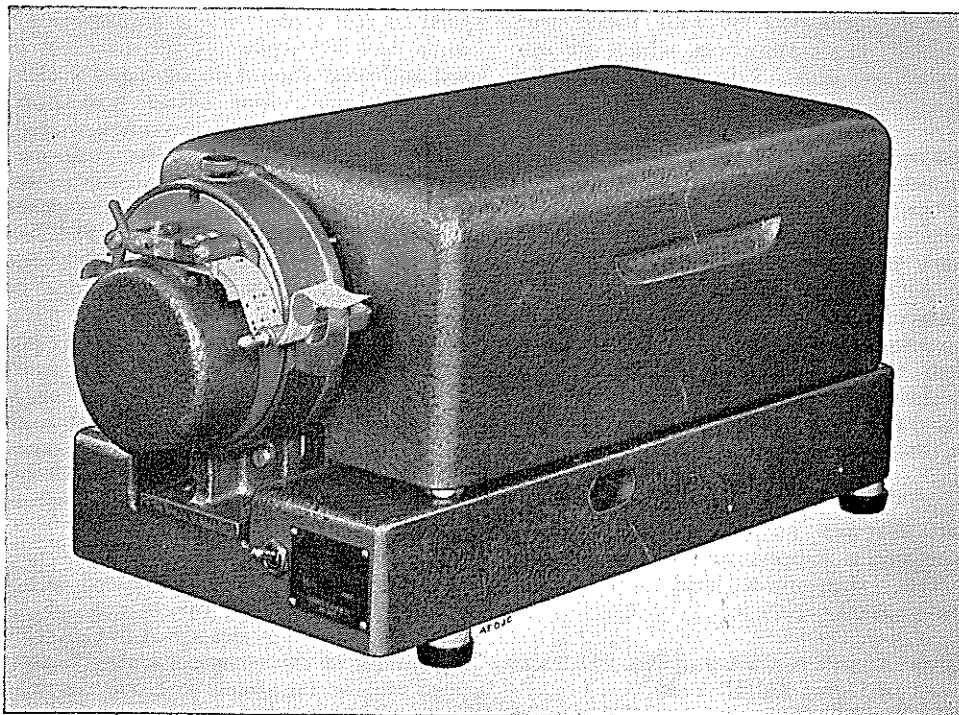

FIG. 1.

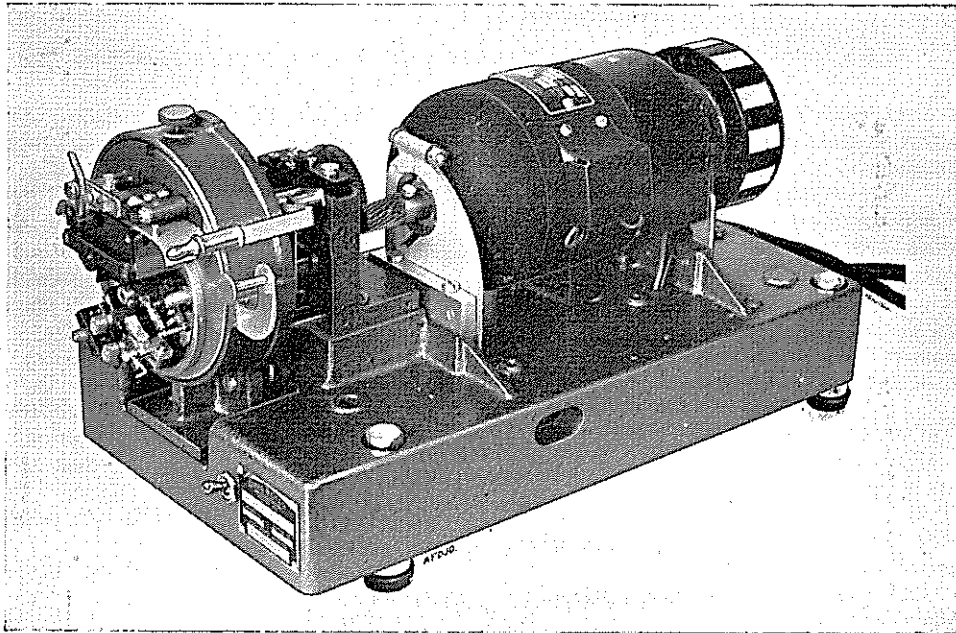

FIG. 2.

same as for the No. 1B transmitter, i.e. height 8 inches; length 15 inches; width 8 inches. The complete machines weigh approximately 30 lb.

3. The cover is supported by four metal feet, mounted on rubber shock-absorbers, which fit into cups on the main base unit. Louvers are provided for ventilation.

4. The main base casting is deeper than that of the No. 1B transmitter and, in addition to supporting the main units, contains the associated electrical components, e.g. governor resistor, connexion blocks and radio interference suppression units. A cover plate encloses the underside of the main base. The machine is supported by four rubber feet, affixed to the main base casting, which are so arranged that the transmitter head may project approximately three inches beyond the edge of the table on which the machine stands. This enables the perforated tape to be fed from, or into, a receptacle which is situated on the floor.

5. Radio-interference suppression units are provided for the mains supply, motor commutator, governor contacts, transmitter and send/receive switch contacts.

6. Connexions of both No. 2A and No. 2D transmitters are shown in Dgm. TG(L) 1156.

7. The motor fitted to the transmitters is a "Motor, Electric, D.C., No. 25A" which is similar

to a "Motor, Electric, D.C., No. 13", described in C 1053, but is wound for a lower speed and torque. It has a rated output of 0.008 h.p., with power consumption of approximately 20 watts. The governed speed of the motor, for a transmission speed of 50 bauds, is 1,500 r.p.m. Only two motor brushes are used and these should be arranged to run on the same track (although four brush boxes are provided). When the commutator becomes worn, the brushes may be transferred to the other positions in the brush boxes so that they may run on the unworn track.

The motor may be operated on either of the two voltage ranges, 145 to 170 volts D.C. or 200 to 240 volts D.C., by altering the position of the field straps on the terminal block of the motor body and by altering the position of the voltage selecting link on the motor-connexion block which is situated under the main base. Adjustment of this link connects an additional resistance of 165 ohms or 350 ohms in series with the motor for a nominal voltage of 160V. or 220V., respectively. These resistances are derived by utilizing tapings on the governor resistor.

A hole in the base-plate allows access to the link on the motor-connexion block.

8. The governor.—The speed of the motor is maintained constant by means of a centrifugal governor of the type described in C 1009. By suitable adjustment of the governor-spring tension, the motor speed can be regulated to 1,500 r.p.m. (for 50-baud working). The governing resistor is a 2,350-ohm vitreous type with taps at 185 ohms and 350 ohms from one end. The 2,000-ohm section forms the

actual governing resistance and the end sections are arranged for connexion in series with one motor supply lead for the purpose referred to in par. 7.

A spark quench, comprising two 20-ohm, 20-watt, vitreous resistors and a $.01\mu\text{F}$. capacitor, is provided for the governor contacts.

9. Speed check facilities.—For 50-baud working, the method of checking motor speed is by viewing the twelve white segments on the governor cover through a "Stroboscope No. 19".

10. Tape-control unit (see Fig. 3).—This unit is similar to that of a No. 1B machine but it has an adjustable retention lever and a send-receive switch of an improved design. Cam rollers are fitted on the retention and send-receive switch levers of No. 2D machines.

11. The "Oldham" type of coupling is used on the No. 2D machines to minimize distortion of signals because the spigot-type driving coupling used on the No. 1B and on the No. 2A machines can introduce

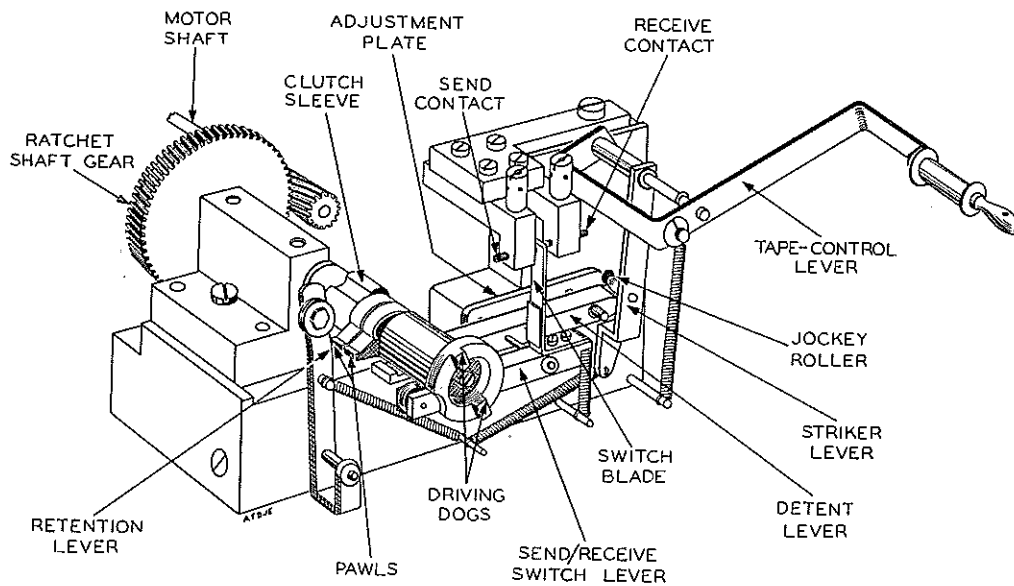

FIG. 3.—TAPE-CONTROL UNIT (SCHEMATIC)

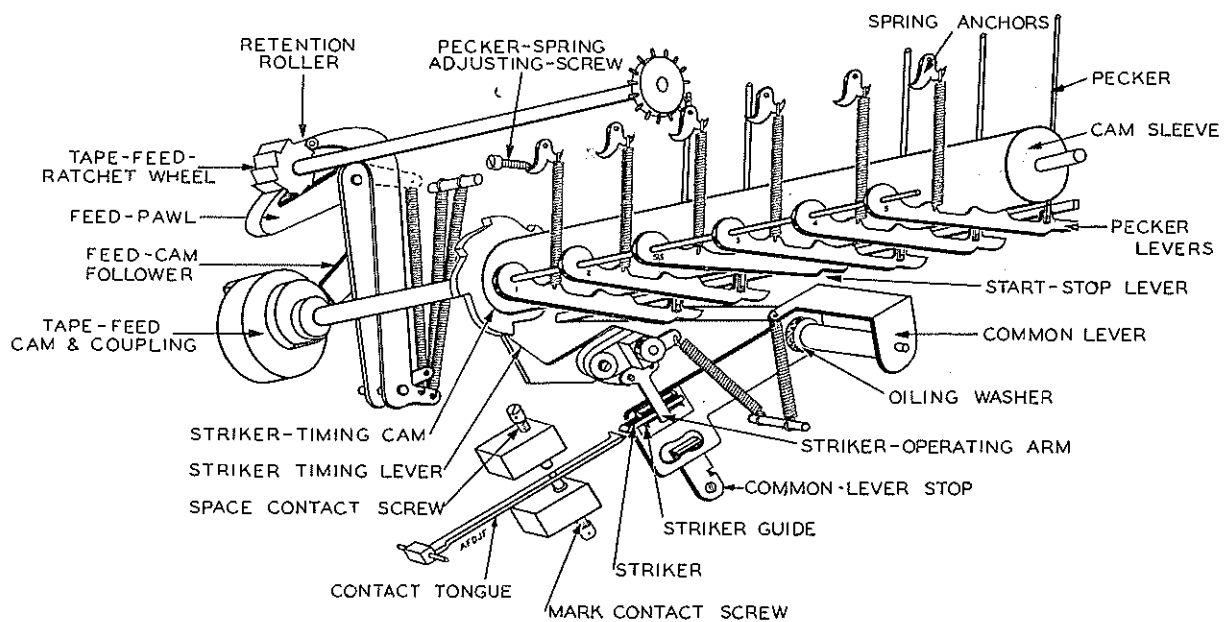

FIG. 4.—STRIKER-TYPE TRANSMITTER HEAD (SCHEMATIC)

signal distortion if the coupling is not accurately in alignment with the clutch sleeve. The use of an "Oldham" type coupling has necessitated changes to the clutch sleeve to include driving dogs. The coupling disk is the same as that used on the Teleprinter No. 7B.

STRIKER-TYPE TRANSMITTING MECHANISM OF A TRANSMITTER, AUTO., No. 2D (See Fig. 4)

12. General.—The signal distortion of transmitting units of the type used in No. 1B and No. 2A machines depends to a great extent on the condition of wear of the cam tracks and pecker levers, as each lever together with its associated cam track is responsible for the timing of signal elements.

The striker-type transmitting unit, therefore, has been designed on the same lines as that of the Teleprinter No. 7 to include additional mechanism for accurately timing the signal elements, thus making the timing independent of the cam sleeve tracks and selecting levers. This timing mechanism necessitated changes in design of the following components:—

- (a) Transmitting cam-sleeve
- (b) Contact-operating lever
- (c) Contact tongue
- (d) Jockey pressure-roller assembly.

The different method of operation also necessitates a reversal of the connexions to the fixed contacts, i.e. the contact located on the lower right-hand side of the contact tongue is the "Marking" contact.

13. The tape-feed mechanism.—The paper tape passes over the pecker guide-plate and is held in contact with it by the tape-retaining plate. It is drawn through the transmitter head one feed hole at a time by means of a star wheel, which is advanced by one tooth during the transmission of each stop signal element. This is accomplished by means of a ratchet and pawl operated from a cam, which is secured to the rear of the transmitting cam spindle.

As the tape is stationary while being sensed by the peckers, the pecker holes in the pecker guide plate are not "staggered" as on a No. 2A machine but are in line across the plate.

14. The transmitting cam-sleeve has six flats cut in its surface and these are arranged so that the pecker levers, if otherwise free to do so, may rise successively under the tension of their associated springs at the correct instants as the cam sleeve rotates. A rack is provided to ensure lateral stability for the pecker levers.

In addition, the cam-sleeve has a timing cam

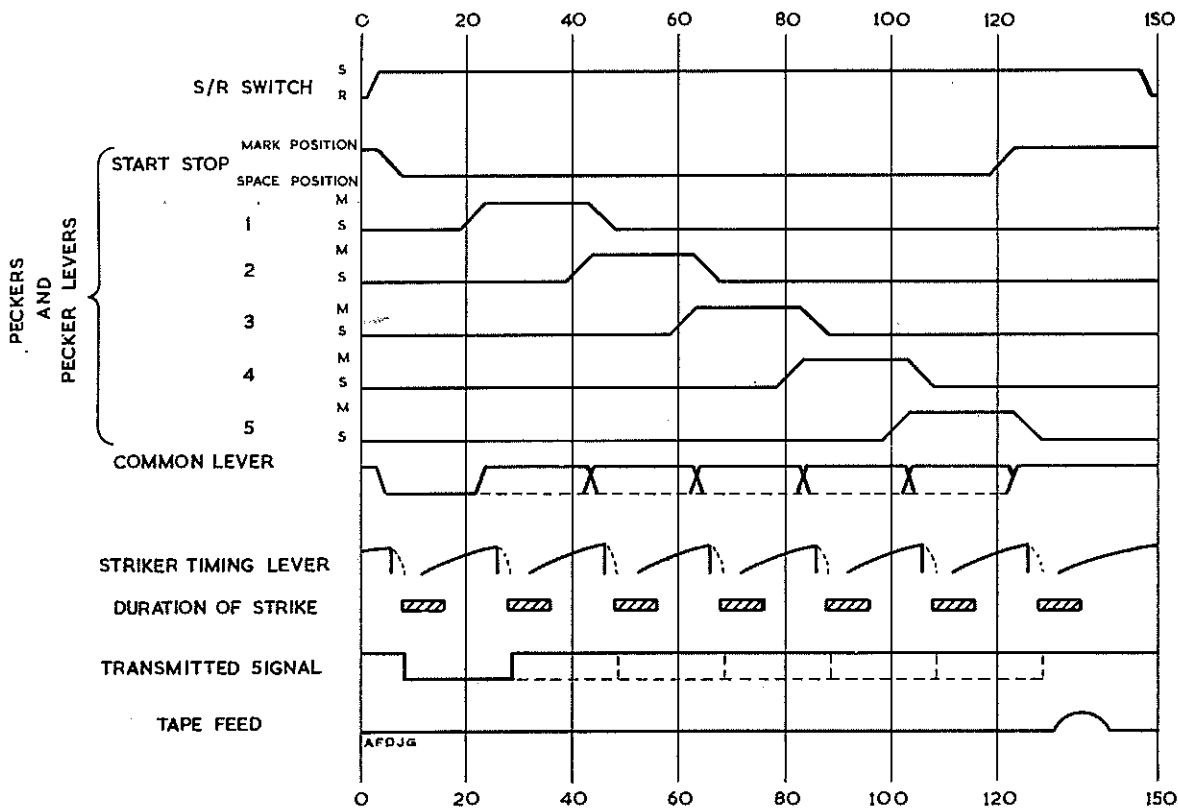

FIG. 5.—TRANSMITTER, AUTOMATIC, NO. 2D — TIMING DIAGRAM

secured on its rear end. This timing cam has seven indentations cut in its periphery and is secured to the cam-sleeve so that the indentations are in correct phase relationship with respect to the operating portion of each signalling cam.

Fig. 5 shows schematically the relative timing of the cam operations.

15. The pecker levers.—The five pecker levers are mounted side-by-side on a spindle. In its normal position, each lever is horizontal and extends under the transmitting cam-sleeve, the upper edge of the lever being kept in contact with the surface of the cam-sleeve by the tension of a spring. A pecker is attached near to the right-hand end of each of the five levers and the extreme right-hand end of each lever projects under an extension of the common lever. Therefore, the movements of each pecker lever control the position of the common lever which, in turn, positions the striker with respect to the tongue knife-edge.

A sixth lever, called the "start-stop" lever, is mounted on the same spindle as the pecker levers and is situated between levers Nos. 2 and 3, i.e. vertically under the train of feed holes in the tape. This lever is similar in design to the pecker levers, except that it has no pecker associated with it and is therefore free to ride onto the flat on its associated cam track on every revolution of the cam sleeve.

The position of the cam-sleeve ensures that when the pawls have been de-clutched and the sleeve is at rest, the "start-stop" lever is in a raised position. Individual adjustments are provided for the pecker lever springs, which are anchored on small adjustable bellcrank-shaped levers and tensioned by a screw adjustment.

16. The peckers, of which there are five, are thin steel rods each of which is attached at its lower end to one of the pecker levers; the upper end of each rod passes into its respective hole in the pecker guide-plate. The function of the peckers is to sense the tape for perforations; the sensing being carried out by each pecker successively as its associated lever rides onto the flat on the cam sleeve.

When the pecker levers are in their lowered position the top ends of the peckers are located just below the upper surface of the guide-plate and, therefore, do not touch the tape.

17. The common lever is a bellcrank-shaped lever pivoted at its angle with an extension on its upper arm projecting towards the front of the machine and this extension is situated just above the right-hand ends of the pecker levers. The lower arm carries the striker in its insulated guide.

The movements of the common lever are controlled by the movement of the pecker levers which, in turn, move according to the perforations in the paper tape. The common lever positions the striker over one side or the other of the transmitting tongue knife-edge.

18. The striker-timing lever.—This consists of two parts: a cam follower and an operating arm, mounted on an insulated block through which the pivot spindle passes. The cam follower is maintained in contact with the timing cam by spring tension and the operating arm engages with a slot situated in the striker.

When the cam rotates, the timing-lever cam follower follows the contour of the timing cam; operating once for each signal element, causing the striker knife-edge to "chop" the tongue over from "mark" to "space", or *vice versa*.

19. The striker is a small dart of rectangular cross section with a knife-edge at one end. It is carried in an insulated guide situated on the lower arm of the common lever.

20. The transmitting tongue is the same as that used on a Teleprinter No. 7. Two knife-edges are provided at the free end, one for the striker operation and the other for the jockey roller.

21. The jockey roller pressure assembly consists of a frame, one end of which is pivoted on an adjustable eccentric pivot and the other end carries the jockey roller on a spindle; spring tension holds the roller in contact with the front knife-edge of the transmitting tongue.

OPERATION OF THE TRANSMITTER, AUTOMATIC, No. 2D

22. General—Manual control for starting and stopping the machine.—When transmission is about to begin, the tape-control lever should be positioned in its highest position and the motor switched on. The tape-control lever should be lowered when the tape is in position and transmission ready to commence. The jockey roller on the striker lever of the tape-control unit is transferred to the lowest of the three inclined surfaces of the pawl-abutment lever, thus causing the abutment face to be withdrawn from the clutch pawls, which then engage with ratchet teeth on the revolving ratchet shaft. The clutch sleeve then begins to rotate and transmission commences. Similarly, when transmission is to cease; the tape-control lever should be raised to its highest position, by hand, before the motor is switched off.

The above procedure ensures that transmission takes place while the machine is running at governed speed.

23. Operation of the transmitting mechanism: Transmission of the "start" element.—While the transmitter-head mechanism is in the rest position, the striker timing-lever cam follower is depressed by a lobe of the timing cam to hold the striker clear of the contact tongue. When the tape-control lever is lowered, the clutch pawls are released, engage with the ratchet-shaft teeth, and the transmitting-cam

commences to rotate. As it rotates, the "start-stop" pecker is depressed by the cam, causing the common lever to rotate anti-clockwise about its pivot under the action of its spring, and move the striker to a position over the lower right-hand face of the contact-tongue knife-edge.

The timing cam is rotating with the transmitting cam and, shortly after the common lever has come to rest against its stop, the cam follower of the striker-timing lever enters the first indentation of the timing cam. The striker-timing lever then rotates about its pivot, under the action of its tension spring, and sharply drives the striker downwards against the right-hand face of the contact-tongue knife-edge. This blow forces the contact tongue from the "mark" contact (right-hand) to the "space" contact to commence transmission of the "start" signal element. A jockey roller, acting upon a second knife-edge, holds the contact tongue firmly in whichever position it is set by the striker.

24. Transmission of first code element.—The cam-sleeve continues to rotate and causes the second lobe of the timing cam to depress the follower of the striker timing lever. The operating arm of the timing lever lifts the striker clear of the contact tongue, which remains held in position against the "space" contact by the jockey roller. The first pecker lever rides up onto its cam flat and its associated pecker rises to sense the tape. Assuming that the first signal element is a "mark", the pecker is able to rise through the perforation in the tape. The pecker lever comes into contact with the arm of the common lever, partially rotating it in a clockwise direction, to position the striker over the upper left-hand face of the contact-tongue knife-edge. The follower of the striker-timing lever enters the second indentation of the timing cam thus allowing the striker-timing lever to rotate about its pivot under

the action of its tension spring and sharply drive the striker downwards against the left-hand face of the contact-tongue knife-edge and this forces the tongue over from the "space" to the "mark" (right-hand) contact, to commence transmission of the first code element at the correct instant, i.e. 20 milliseconds after the commencement of the "start" element. The remaining code elements are transmitted in a similar manner.

25. Transmission of consecutive elements of the same polarity.—When a "space" or "mark" element is followed by elements of the same polarity, the contact tongue is not moved from the contact on which it is resting until an element of the opposite polarity has to be transmitted. The striker, however, continues to strike the contact tongue knife-edge at the appropriate instants corresponding to the terminations of the individual elements. The strikes occur on the same side of the contact tongue which, therefore, remains in the one position under the action of the jockey roller.

26. Tape-feed mechanism.—The step-by-step tape-feed mechanism is fitted in the recess at the back of the transmitter-head casting. A tape-feed cam is situated on the rear end of the transmitter-head driving spindle, and a ratchet wheel is provided on the tape-feed spindle. A retention lever is used to locate the ratchet wheel, so that the tape-feed wheel takes up the correct position relative to the peckers, after feeding the tape forward. The tape remains stationary while the code elements are transmitted, then, during the "stop" signal element, the tape-feed cam moves the tape-feed pawl into engagement with the ratchet wheel to advance it by one tooth. The tape-feed wheel is thus rotated to feed the tape forward by one feedhole, in readiness for the transmission of the next character.

References:—C 1009, C 1053, J 1001, J 1002, J 5011
(Tg 1/1) J 5301 to J 5309

Instruction cancelled:—J 1012

END