

KIOSK NO. 6

Erection Instructions

★[NOTE.—As this Instruction has been completely revised, individual paragraphs have not been “starred”]

1. General.—This Instruction describes the assembly and erection of a Kiosk No. 6. The separate parts comprising the complete structure may be transported for assembly and erection on the site or they may be assembled at a convenient central depot in the Area and then transported to the erection site by means of a “Single Kiosk Trailer” (see par. 39). Assembly at a central point should be adopted wherever possible, because the work of installing the internal fittings (wallboards, telephone, electric light, etc.) and the initial decorative treatment may be completed expeditiously and, if under cover, independently of weather conditions; the time spent at the site is thereby reduced to a minimum and a favourable impression is produced on the public.

2. It is important that arrangements shall have been made with all concerned—including the electricity authority—for the preliminary work to be performed in accordance with a predetermined program. Such a program should ensure that arrangements for:—

- (a) the preparation of the site,
- (b) the availability of the electricity supply service lead,
- (c) leading-in the telephone and earth leads,

(d) the fitting of the telephone apparatus (when the kiosk is not being transported completely equipped to the site, see par. 39),

(e) the exchange termination and jumpering, and

(f) the preparation of notices and dial labels are completed in ample time so that, as soon as the kiosk has been erected, service can be made available from it immediately, if necessary. This Instruction assumes that such a program is to be put into effect.

3. Description of Kiosk No. 6 (Mk. 2).—This kiosk comprises 18 cast-iron parts, as scheduled in Table 1, which also indicates their approximate weights. Fig. 1 shows the main parts of the kiosk.

Other average weights are:—

Kiosk, glazed, and fitted with door—14½ cwt.

Kiosk as above, but with wallboard and coin-hox fitted—15 cwt.

Total weight on foundation, including weight of cement in sill—approx. 1 ton.

Kiosk No. 6 (Mk. 2) incorporates the following improvements over the Mk. 1 type, which is not now supplied:—

(a) Four tapped hoses, provided on the back panel, which allow the coin-hox to be holted through the wallboard into the back of the kiosk, thus giving greater security.

TABLE 1

Cast-iron parts	Approx. average weight		
	cwt.	qrs.	lb.
1 Sill frame	1	0	7
2 Side panels, each	1	1	0
1 Back panel	2	0	2
2 Front, corner pillars (each)	—	3	11
2 Rear, corner pillars (each)	—	3	1
1 Front transom-rail	—	1	7
1 Rear transom-rail	—	—	23
2 Side transom-rails (each)	—	—	23
1 Front Crown panel (including Crown Ornament)	—	1	0
1 Rear Crown panel	—	1	0
2 Side Crown panels (each) (including Crown Ornament)	—	1	0
1 Dome top	1	1	17
1 Glazing frame for door	—	2	16
24 „ „ beads, large (total)	—	1	0
48 „ „ beads, small (total)	—	—	24
Total weight of castings	13	0	26

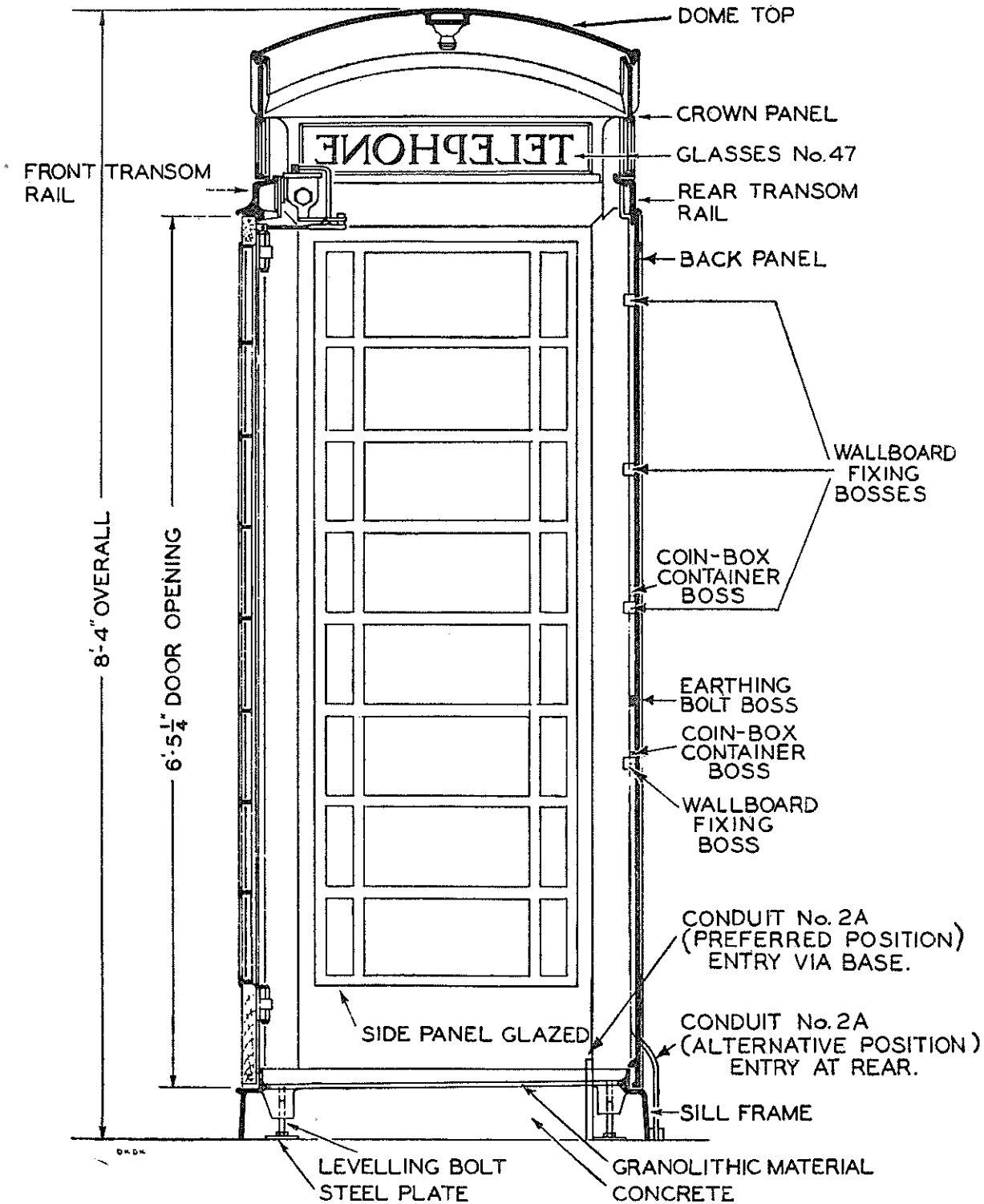

FIG. 1. KIOSK No. 6—SHOWING COMPONENT PARTS

(b) Glazing-frame beads fixed by dowels and pins facilitate the replacement of broken glass. The glazing-frame beads are not interchangeable with those used in the Mk. 1 type. The beads are secured by friction-tight, $\frac{3}{16}$ -in. brass pins in all horizontal members, except for the extreme top and bottom members, where dowels are employed. (To remove a bead, the pins need only to be driven back a

sufficient distance to release the bead; it is unnecessary to remove the pins completely. The dowels in the beads in the top and bottom rows can be left undisturbed.)

(c) A thin metal 'knock-out' web is provided in the back panel in the position where, previously, holes were provided for leading-in at near-floor level. This 'knock-out' can be removed, if necessary, to provide leading-in facilities, see also par. 35.

4. Fittings issued with the kiosk are shown in Table 2. Table 3 lists the kit of screws, etc. which is also supplied with each kiosk, and gives brief details of where each item is used. This kit is a Rate Book item bearing the title "Kit No. 35" and items marked with a dagger † are separate Rate Book items.

TABLE 2

Quantity	Fittings (Rate Book Titles)
1	Spring, Door-closing No. 5, R.H. or L.H.
3	Hinges, Brass, No. 2
4	Shackles No. 5 (for Straps, Restraining, No. 2)
2	Straps, Restraining, No. 2
1	Pendant P4, Brass
1	Disk, Fibre (for Pendant P4, Brass)

TABLE 3

CONTENTS OF BAG OF SCREWS ETC. SUPPLIED WITH KIOSK No. 6, Mk. 2
("KIT No. 35")

Quantity	Screw size and description (All have B.S.W. threads and are of steel, unless otherwise stated)	Use
4	$\frac{1}{2}$ in. \times 3 in., Hex. Conical Hd.	Levelling screws (used with 4 pieces of mild steel plate, 3 in. \times 3 in. \times $\frac{1}{4}$ in.)
8	$\frac{3}{8}$ in. \times $1\frac{1}{8}$ in., Rd. Hd.	Corner pillars to base
†2	$\frac{1}{2}$ in. \times $1\frac{1}{2}$ in., Rd. Hd.	Door transom to corner pillars
61	$\frac{5}{16}$ \times 1 in., Csk. Hd.	{ Transoms to corner pillars and sides Crown panel to corner pillar Sides to corner pillars
4	$\frac{3}{16}$ in. \times $\frac{5}{8}$ in., Csk. Hd.	Crown panels to transoms
9	$\frac{3}{8}$ in. \times $1\frac{1}{4}$ in., Rd. Hd.	Sides to base
8	$\frac{5}{16}$ in. \times 1 in., Rd. Hd.	Dome to crown panel
1	$\frac{3}{8}$ in. \times $\frac{3}{4}$ in., Hex. Hd., Brass	Earth bolt (used with two Washers, Brass, $\frac{3}{8}$ in. inside diam. \times $\frac{7}{8}$ in. outside diam., and Socket, Soldering, No. 8D)
6	$\frac{1}{4}$ in. \times $\frac{1}{2}$ in., Csk. Hd., Brass	Hinge to corner pillar—short
15	$\frac{1}{4}$ in. \times $\frac{5}{8}$ in., Csk. Hd., Brass	{ 9 for hinge to corner pillar—long 6 for Shackles No. 5
2	$\frac{1}{4}$ in. \times $\frac{3}{4}$ in., Csk. Hd., Brass	Time switch to back panel
4	$\frac{1}{4}$ in. \times $1\frac{1}{4}$ in., Csk. Hd., Brass	Hardwood block (E.L. Co.'s Cut-out) to back panel
8	$\frac{3}{16}$ in. \times $\frac{5}{16}$ in., Rd. Hd., Brass	Cable cleats—Lighting conduit to back panel
4	$\frac{1}{4}$ in. \times $\frac{5}{8}$ in., Csk. Hd., Brass	Door closer to transom
8	$\frac{1}{4}$ in. \times 1 in., Rd. Hd., Brass	Wallboard to back panel
3	$\frac{3}{16}$ in. \times $\frac{3}{4}$ in., Rd. Hd., Brass	E.L. pendant
2	$\frac{3}{16}$ in. \times $\frac{3}{4}$ in., Hex. Hd.	For fixing Capping, Steel, No. 6 to back panel
†1	$\frac{5}{16}$ in., 2 in., Grub screw	To hang coin-box container while securing
4	Screws, for Wood, No. 6, Csk. Hd., Stainless steel	Handle, Pull, to door
2	Carriage Bolts, Mushroom Hd., $\frac{1}{2}$ in. \times $1\frac{3}{4}$ in.	Door closer, Door bracket ("Shackle No. 6") to door (include two Hex. Nuts)
6	Screws, for Wood, Brass, No. 12, $1\frac{1}{4}$ in.	Shackles No. 5, to door
15	" " " " No. 14, $1\frac{1}{4}$ in.	Hinges to door
16	Glazing Pins, Brass, $\frac{1}{8}$ in. \times $\frac{3}{4}$ in.	Preliminary securing of Glasses No. 47 or 47A
4	Pieces, M.S. Plate, 3 in. \times 3 in. \times $\frac{1}{4}$ in.	Levelling plates for sill
2	Washers, Brass, $\frac{3}{8}$ in. \times $\frac{7}{8}$ in.	For use with earth bolt
†1	Socket, Soldering, No. 8D	" " " " "

5. Assemblies.—"Kiosk No. 6 (Mk. 2)" is available in four assemblies, for use under various conditions (see Fig. 2) as follows:—

"Kiosks No. 6A"; door fitted opposite back panel and hinged left

"Kiosks No. 6B"; door fitted opposite back panel and hinged right

"Kiosks No. 6C"; door fitted on the left side-panel and hinged left

"Kiosks No. 6D"; door fitted on the right side-panel and hinged right.

The Crown Ornament is detachable; for use in Scotland, "Scottish Crowns" are requisitioned and supplied; for use elsewhere in the British Isles, "St. Edwards Crowns" are supplied.

6. Stores to be obtained on requisition are as follows:—

"Kiosk No. 6A, B, C, or D—see STORES General, F 0018

"Glasses No. 47" (and "No. 47A")—see par. 9
Wallboard and Telephone items—see D 3001 and D 3003

"Capping, Steel, No. 6"—for underground lead-in, in all but magneto areas

or

"Conduit No. 2A," "Saddle, Conduit, No. 2A" and "Tee-piece, Conduit, No. 2A"—for underground lead-in, in magneto areas

or

"Bracket No. 19"—for overhead leading-in

See par. 14 and pars. 34 to 38

Paint, enamel and varnish—see C 3002

Lighting equipment—see POWER, Lighting, A 3101

Putty (London only)—8 lb.

Oil, linseed, raw—1 pt.

Earthing-wire and earth-spikes (or earth-plates)—see pars. 13 and 36

Items to be purchased locally:—

Putty (Provinces only)—8 lb.

Cement, sand and ballast—see par. 32

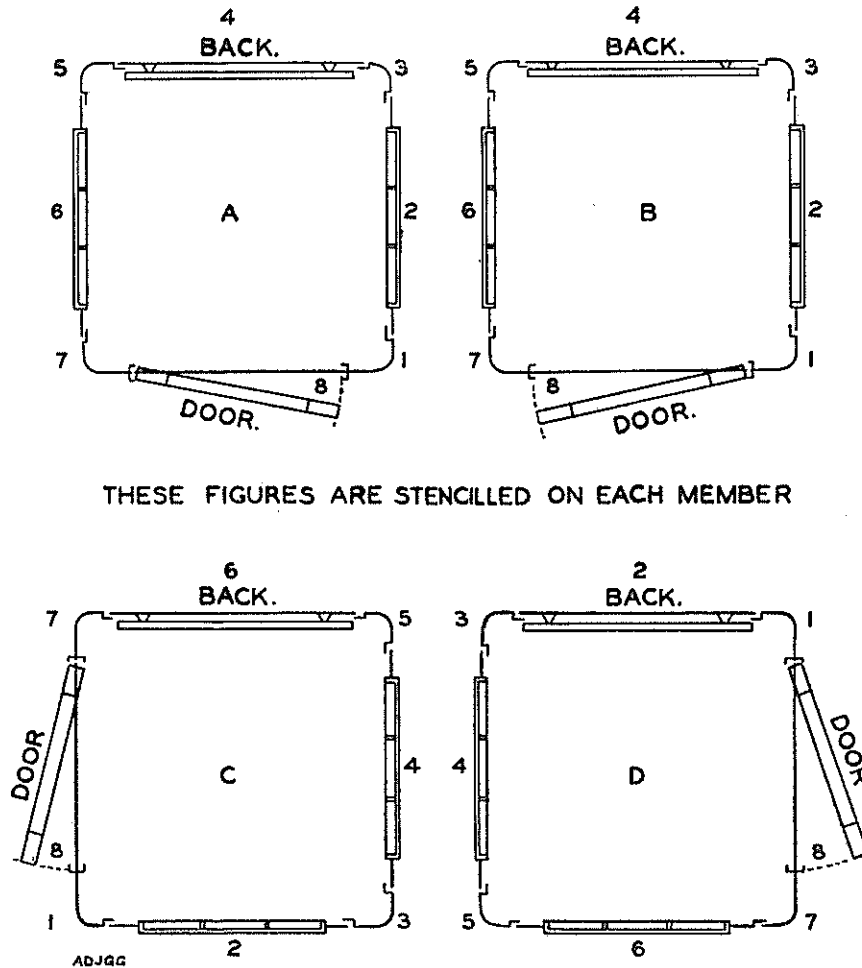

THESE FIGURES ARE STENCILLED ON EACH MEMBER

FIG. 2. KIOSK NO. 6—NUMBERING OF SECTIONS AND IDENTIFICATION OF ASSEMBLIES

7. Transport.—The door and glazed sections of the kiosk are forwarded in wooden cases and the remaining sections are bundled in straw. The cases are the property of the contractor and, after they have been unpacked, should be returned to the contractor at the earliest possible moment. If, for any reason, the work of assembly is delayed the parts may be retained in their cases until assembly is commenced, but the cases should be returned immediately they are unpacked. When a kiosk is assembled at a central point in the Region or Area and is transported to site, great care should be taken to ensure that the kiosk parts are firmly assembled and the whole structure strongly secured to the trailer. This is to ensure that the kiosk is neither damaged, nor weakened, by vibration during transit or while it is being manhandled.

8. Precautions when handling kiosks parts.—The cast-iron parts of the kiosk are brittle and liable to fracture if mishandled; great care must be taken in unpacking and erecting them. The method of storage must be such that the danger of breakage and rusting is minimized; for example, corner pillars should be stored flat, but sides and backs are probably safest when stored vertically, while the dome should be stored with its concave face downwards.

9. Glazing. (a) "Glasses No. 47 and No. 47A."—A total of four of these are required. They are manufactured of toughened $\frac{1}{4}$ -in. plate glass. The "Glass No. 47" has the lettering and white background fired on, but the "Glass No. 47A" is plain. As manufactured, they are the correct size for fitting into the crown panels, and no attempt should be made to cut or trim them locally, as this will result in the glass being shattered. The four glasses should be fitted one in each of the four panels before the kiosk is erected, each glass being secured with putty. Glazing pins are provided and should be used to hold the glass in position before the putty is applied. The use of these pins will ensure that the glasses are not loosened, by wind or vibration, while the putty is setting. A "Glass No. 47" is fitted in kiosk sides visible to the public from the outside. If one or more sides of the kiosk will be obscured by adjacent buildings, walls, etc. a "Glass No. 47A" should be inserted on that side.

(b) *Toughened glass panes.*—The 13 lower large panes (five in the door) are of toughened glass. If called for in the erection instructions, additional panes ("Glasses No. 62D") should be requisitioned and fitted (see C 5904).

10. Electric light cable.—The electricity authorities will run this cable and they should be consulted well in advance as to the method they are to use to lead it in, so that suitable provision for entry can be made while the foundation is being laid. Instructions relating to the layout of the electric light terminations and equipment, etc. will be found in POWER, Lighting, A 3101.

PREPARATIONS AT SITE

11. Prior to erecting the kiosk, certain preparations are required at the site, and the following paragraphs describe the work to be done.

12. The underground services and earth-electrode system should preferably be laid before preparing the foundations, so that the site can be thoroughly consolidated before the kiosk is erected. If this cannot be arranged, suitable entries should be provided by means of "Bends, Asbestos-cement and Ducts, Asbestos-cement," to allow the cables to be drawn-in without disturbing the foundations. Such ducts must terminate below the final floor level.

13. Earth electrode.—This should be provided by means of earth-spikes or earth-plates, as described in PROTECTION, General, S 3901.

14. Telephone cable and earth wire.—For new work, generally, the telephone cable and earth wire should be run in conduit and brought in through the concrete floor. In all except magneto areas, the conduit should terminate about $\frac{3}{4}$ in. above the final floor level, in the position shown in Figs. 1 and 3A. Accurate location of the conduit is required; it is, therefore, suggested that a template be prepared, based on the dimensions of Fig. 3A and used to locate the conduit. In magneto areas, the conduit should extend 9-10 in. above the final floor level, to enable the lead-in arrangements shown in Fig. 4 to be used.

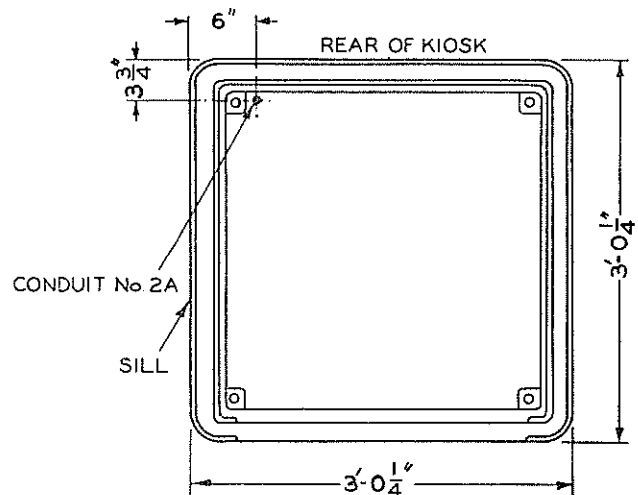

FIG. 3A. POSITION FOR LEAD-IN CONDUIT NO. 2A, WHEN CAPPING, STEEL, NO. 6 IS USED

15. Foundation.—Before placing the kiosk in position, the site should be made firm and level. Depending upon the conditions existing at the site, the foundation should be prepared as follows:—

(a) *Unpaved ground.*—If the soil is firm, the whole site should be well punned and an engineering or sewer brick rammed in at each corner to support the sill-leveling bolts. If any doubt exists as to the

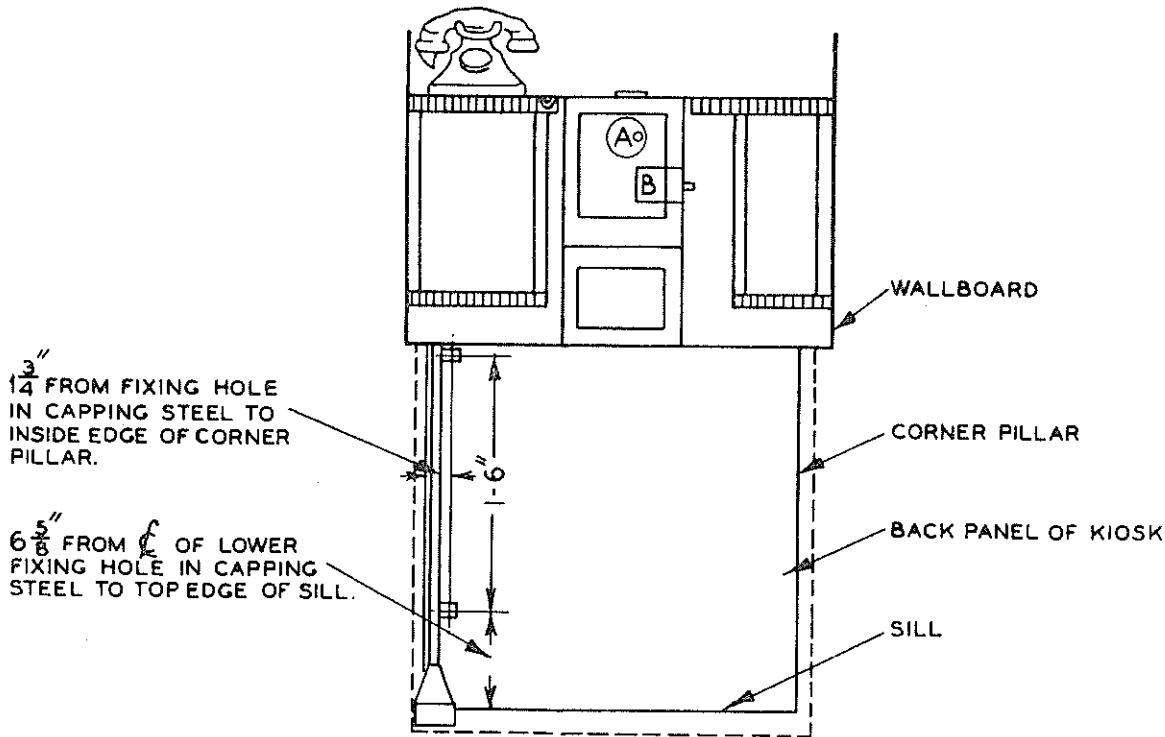

FIG. 3B. POSITION OF CAPPING, STEEL NO. 6 ON BACK PANEL

firmness of the site, a foundation of "A" quality concrete, i.e. one part of Portland cement, two parts sand and four parts aggregate, of a depth of from 4 in. to 6 in., should be provided to support the sill frame. This foundation should be put in before the kiosk parts are delivered on site. [NOTE.—Aggregate comprises clean, screened river ballast, gravel stone or other material (as approved) of the nature of cubes, not flaked, and graded in size up to $\frac{3}{4}$ in.]

(b) *Level, paved ground.*—A concrete foundation is not usually required.

(c) *Sloping ground.*—If a kiosk is to be erected on ground having a considerable slope, a concrete foundation [see sub-para. (a)] is required to provide a level base for the sill frame. The depth of the concrete foundation should be such that the step into the kiosk is but little greater than the depth of the sill frame. If necessary, a step should be formed in the foundation. When laid, the foundation should be protected from the action of frost, shielded against too-rapid drying by exposure to the sun or wind, and guarded for at least 48 hours, to ensure that it will be set thoroughly before erection operations are commenced.

(d) *Drainage.*—When necessary a channel should be provided along the upper edge of the foundation, to deflect the surface rain-water from the kiosk.

ERECTION OF THE KIOSK

17. *General.*—It is essential that the erection of the kiosk be commenced sufficiently early to ensure that the work, including the filling-in of the sill frame with concrete (see par. 32), shall be completed in one day.

18. The sill bears numbers at the corners and sides, as indicated in Fig. 2, and all the other sections are numbered to indicate their positions relative to the sill, e.g. a transom rail marked 2 should be erected above the side of the sill which is marked 2.

19. *Joints.*—These should be brushed with a thin coating of linseed oil, and served with sufficient putty to seal up the joints. The screw threads of the various parts will have been protected with a special preparation before leaving the works but, if necessary, should be cleared of any priming, paint or rust, by means of appropriate Whitworth taps.

20. *Securing the various parts.*—In the course of erection, *screws should not be driven right home until all the parts have been assembled.* All the screws should then be tightened up by means of the "Braee, Carpenter's" and "Bit, Screwdriver, $\frac{1}{2}$ in., $\frac{5}{16}$ in. or $\frac{3}{16}$ in."; any surplus putty exuded from the joints, or resin from the screw holes, should then be removed.

KIOSK No. 6
Erection Instructions

[Additional par. 15(d)]

Par. 15 *The following sub-par. is added:-*

(d) *Approach to kiosk.* When the approach to the kiosk is across soft ground or grass verges, a path made of concrete or similar suitable material should be provided to the nearest firm pathway. Unless the local authority offer to provide a footpath, the T.M.(Sales Divn.) should obtain their agreement for a footpath when negotiations are being transacted. When a concrete path is constructed it should be of "A" quality concrete [see sub. par. (a)] and be approximately two feet wide and a minimum depth of two inches. Where necessary, suitable shuttering should be used to ensure a neat job.

[*The main instruction should be suitable annotated pending reissue*]

21. If two screw holes in adjacent parts do not line-up accurately, the parts may be adjusted into position, by inserting the 8½-in. tommy bar into a pair of neighbouring screw holes and levering in the desired direction. If there is any difficulty in getting the screw to pick-up the thread in the hole, the hole should be re-tapped by means of the appropriate tap. Where space is limited the "Vice, Hand, 4½ in." may be used as a wrench.

22. Erection of sections and location of screws supplied.—When the foundation has been prepared, the kiosk sections should be erected in the order in which they are referred to, and in accordance with the methods described, below. *NOTE*:—During erection, all screws should be left about 1½ threads loose until erection of all parts has been completed, as described in (b) to (h), and, when all parts are correctly bedded into their final positions, all screws should be finally tightened, with the exception of those in the corner pillar on the hinged side of the door (see par. 23).

(a) *The sill frame* should be placed in position, and the four pieces of steel plate supplied with the kiosk should be placed under the four levelling bolts. When the site chosen is on a pavement which slopes slightly, but not so much as to necessitate a concrete foundation, it may be necessary to back up the steel plates with material procured locally, to obtain the required horizontal position. Use a spirit level to check that the sill frame is perfectly level before erection commences.

(b) *The corner pillars* should then be secured at the four corners, by means of the eight "Screws, Whit., M.T., Rd. Hd., ¾ in. dia. × 1½ in."

(c) *The back and side panels* should then be placed in position and secured to the sill frame by means of 9 "Screws, Whit., M.T., Rd. Hd., ¾ in. dia. × 1½ in."

(d) *The corner pillars* should be secured to the panels by means of 30 "Screws, Whit., M.T., Csk. Hd., ⅝ in. dia. × 1 in."

[Scaffolding should be erected at this stage to facilitate the erection of the Crown panels, transom rails and the dome top. Two planks should be placed on trestles across the most accessible side of the kiosk, and a single plank should be placed across the adjacent sides and supported by the double plank and step ladders.]

(e) *Transom rails*.—These four rails should be fixed to the top corner pillars and to the back and side panels, by means of 15 "Screws, Whit., M.T., Csk. Hd., ⅝ in. dia. × 1 in." and 2 "Screws, Whit., M.T., Rd. Hd., ½ in. dia. × 1½ in.," which are used for fixing the transom over the door to the corner pillars.

(f) *Crown panels* should be placed in position and secured to the corner pillars, by means of 16 "Screws, Whit., M.T., Csk. Hd., ⅝ in. dia. × 1 in.," and to

the transoms by four "Screws, Whit., M.T., Csk. Hd., ⅝ in. dia. × ⅝ in."

(g) *The Crown Ornaments* should be slipped into the mitred slots provided. Ensure that all four are correctly in place before proceeding to fit the dome, which locks the Crowns in position.

(h) *The dome* should now be erected. This is done by first lifting the dome to the broad scaffolding and resting it vertically against the side of the kiosk with the dome outwards. Three men on the scaffolding can then readily lift the top and place it in position. It should then be secured from the inside by means of eight "Screws, Whit., M.T., Rd. Hd., ⅝ in. dia. × 1 in."

23. *Fitting of the door*.—An ordinary lath, of a width approximately equal to the thickness of the door, should be tacked along the full length of the bottom edge of the door, to prevent the door splintering during erection. When placed in position, the door should be wedged up as high as possible on the hinged side, while the hinges are screwed to the corner pillar. The door closing spring may be attached to the transom rail before the door is placed in position; but before it is connected to the door, or the restraining straps are secured to the corner pillar, the lath should be removed from the bottom of the door. The screws in the corner pillar should be tightened up as the door is being tested to ensure that it swings freely. *NOTE*:—If the door appears too wide for the aperture, this may be due to one or both corner pillars turning inwards. To remedy this, slacken off the screws at the front of the pillar and tighten those at the side until the door aperture is correct. Then re-tighten the front fixing screws. The fitting of the restraining straps and the door-closing spring may then be completed, see pars. 24 and 29.

24. *Door-restraining straps*.—Two "Straps, Restraining, No. 2" are supplied with each kiosk. The restraining straps should prevent the door from opening to a greater angle than 65° initially, which is approximately an opening of 2 ft. 4 in. as measured from the door jamb to the edge of the door. With the door held open in this position the strain on each strap should be reasonably equal. Straps which do not conform with these conditions should be interchanged with others so that matching pairs are found.

25. "Handle, Pull, No. 1."—Each item is made up of two sections. The front section forms the handle and the rear section is suitably dished to fit into the door recess. Items may be received that are manufactured in chromium plated brass, with the two sections separate, or manufactured in mild or stainless steel with the two sections welded together. The kiosk door, as supplied, has a recess cut in the upright wooden door stile for the door handle. Normally, the handle will be fitted over this by means of the four special screws, supplied in the kit.

26. Alternative position of handle.—The kiosk erection instructions may call for the handle to be fitted higher than is normal. It will then be necessary:—

(a) to cover the existing recess in the door by means of a flat metal plate, cut to shape and drilled locally to take four countersunk fixing screws (this plate should be painted over when the kiosk receives its initial decorative treatment); (b) to cut out a suitable recess in the door stile in a position half-way up the seventh glazing panel counting from the bottom of the kiosk; (c) to fit the "Handle, Pull, No. I" in this new position, after protecting the newly-cut wood with primer. *The handle should not be painted.*

27. "Glass No. 63" (Push-Pull door sign).—This sign is already fitted in the small glazing panel adjacent to the "Handle, Pull, No. I" when the kiosk is received. It should be exchanged with the piece of clear glass in the seventh glazing panel, if the handle is to be raised as described in par. 26.

28. "Spring, Door-closing, No. 5."—One "Spring, Door-closing, No. 5" is supplied with each set of kiosk parts. This item has been fitted and tested at the kiosk foundry and should require no further adjustment locally when fitted to the door, beyond, possibly, a further slight adjustment of the check action. The check action is provided to prevent the door slamming and to prevent injury to kiosk users, whose fingers, ankles, etc. can be trapped by a fast-closing door. A slotted screw, concealed by an extension of the closer body, or by a cylindrical guard which projects from the body of the closer, provides the means of adjustment. The screw should be turned with a screwdriver until the check action comes into operation when the door is within four to six inches from the fully-closed position.

29. Fixing "Spring, Door-closing, No. 5."—The "Spring, Door-closing, No. 5" is supplied already assembled to a metal plate for either left-hand or right-hand door openings. The closer should be securely fixed to the transom rail above the door by means of the four $\frac{1}{4}$ in. \times $\frac{5}{8}$ in. Csk. Hd. brass screws supplied. These should be passed through the holes in the mounting plate and screwed into the four tapped metal bosses moulded in the transom. The auxiliary-arm fixing bracket ("Shackle No. 6") should then be bolted to the top of the door using the mushroom headed bolts provided. These should be passed through the two holes already drilled in the upper frame of the door, the bracket slipped over the ends and, finally, the nuts screwed-up securely. The auxiliary arm of the closer should then be pulled round until it engages with the shackle and the link-pin can be inserted. Where provided, the split pin should then be inserted to lock the link-pin to the closer arm.

NOTE.—Care must be exercised in connecting this arm. If it is released accidentally, it may—without the door loading—fly back sharply and cause injury to anyone, who may be in its path.

The door should then be pulled open to approximately 65° (2 ft. 4 in. opening) and allowed to close under control of the closer. Adjustment of the check should then be made as described in par. 28. No other adjustment should be made locally. If the door closer has been correctly fitted to the transom and to the door and it fails to close the door satisfactorily, it should be replaced by another, and the faulty one returned, via the usual channels, to the Supplies Dept., labelled to show the reason for its return.

30. Cutting-off projecting screw ends.—All visible projecting screw-ends should be cut off flush and smooth with a sharp cold chisel. (*NOTE*:—When it becomes necessary to re-sharpen a cold chisel, one face should be ground flat). Where a screw projects near the edge of a panel the blow should be struck as far as possible away from the edge, i.e. towards the thick part of the panel.

31. Check of vertical alignment of the kiosk.—When the door has been hung and before the sill frame is filled-in with concrete (par. 32), the vertical alignment should be checked by means of a plumb-bob and line (or spirit level) and any adjustment found necessary should be made by means of the levelling screws fitted in the sill frame.

32. Filling-in of sill frame.—When the erection of the kiosk has been completed, the sill frame should be filled-in to within one inch of the curved section with "A" quality concrete [see par. 15 (a), but use for this purpose 'rapid hardening' Portland cement], which should be carefully puddled under the flanges and corners of the frame. A few hours should be allowed for the concrete to set. The floor of the kiosk should then be finally completed with a granolithic surface, flush with the bottom of the curved section of the sill frame, which is designed to give the floor a slight fall towards the door. Holes or crevices must not be left round the telephone or power cable lead-in, since besides being unsightly, they would provide a trap for dropped coins. If entries are provided by asbestos ducts, and the telephone or power lead is not in position when the sill frame is filled, arrangements must be made to fill the space between the leads and the duct as soon as the leads are in position. The granolithic material should be composed of:—

1 part (by volume) rapid hardening Portland cement
1 part (by volume) sand
2 parts (by volume) $\frac{1}{4}$ in. graded granite chippings.

If the granite chippings cannot be obtained locally, a cement-mortar mixing of:—

1 part (by volume) rapid hardening Portland cement

3 parts (by volume) sand should be used.

Approximately 4 to 5 cwt. of concrete and granolithic material are required for filling in each sill frame. The quantity will vary according to the slope of the ground.

33. Prevention of access to the kiosk until the floor has thoroughly set should be achieved by securing the door; when rapid hardening cement has been used, overnight hardening will be sufficient.

34. Leading-in from underground distribution—Protection of leads.—"Capping, Steel, No. 6" is used to cover the telephone cable and earth wire between the floor and bottom of the wallboard, as shown in Fig. 3B. The capping, the top of which slips just under the bottom edge of the wallboard, is held in position with two $\frac{3}{16}$ in. B.S.W. $\times \frac{3}{4}$ in. Hex. Hd. steel screws. The back panels of new Kiosks

No. 6 are tapped to take the fixing screws, but in a kiosk without suitable tapped holes it will be necessary to drill and tap two $\frac{3}{16}$ in. B.S.W. holes in the back panel. The steel capping can be held in place and the correct position for the holes marked, using a centre punch through the fixing lugs of the capping. For kiosks in magneto areas, the conduit should be continued up the left-hand side of the back panel (when viewed from inside the kiosk). The conduit, fitted with a tee-piece to take battery leads (see Fig. 4), should be secured to the back panel by means of "Saddle, Conduit, No. 2A" and two "Screws, Rd. Hd., $\frac{3}{16}$ in. dia. $\times \frac{5}{16}$ in." Tapped fixing holes are provided just above the bottom left-hand edge of the wallboard. The conduit should be continued about 2 in. beyond the conduit saddle so that it will extend just above the lower edge of the wallboard.

35. The holes previously provided in the back panel for leading-in at near-floor level are now covered by a thin 'knock-out' metal web and, as

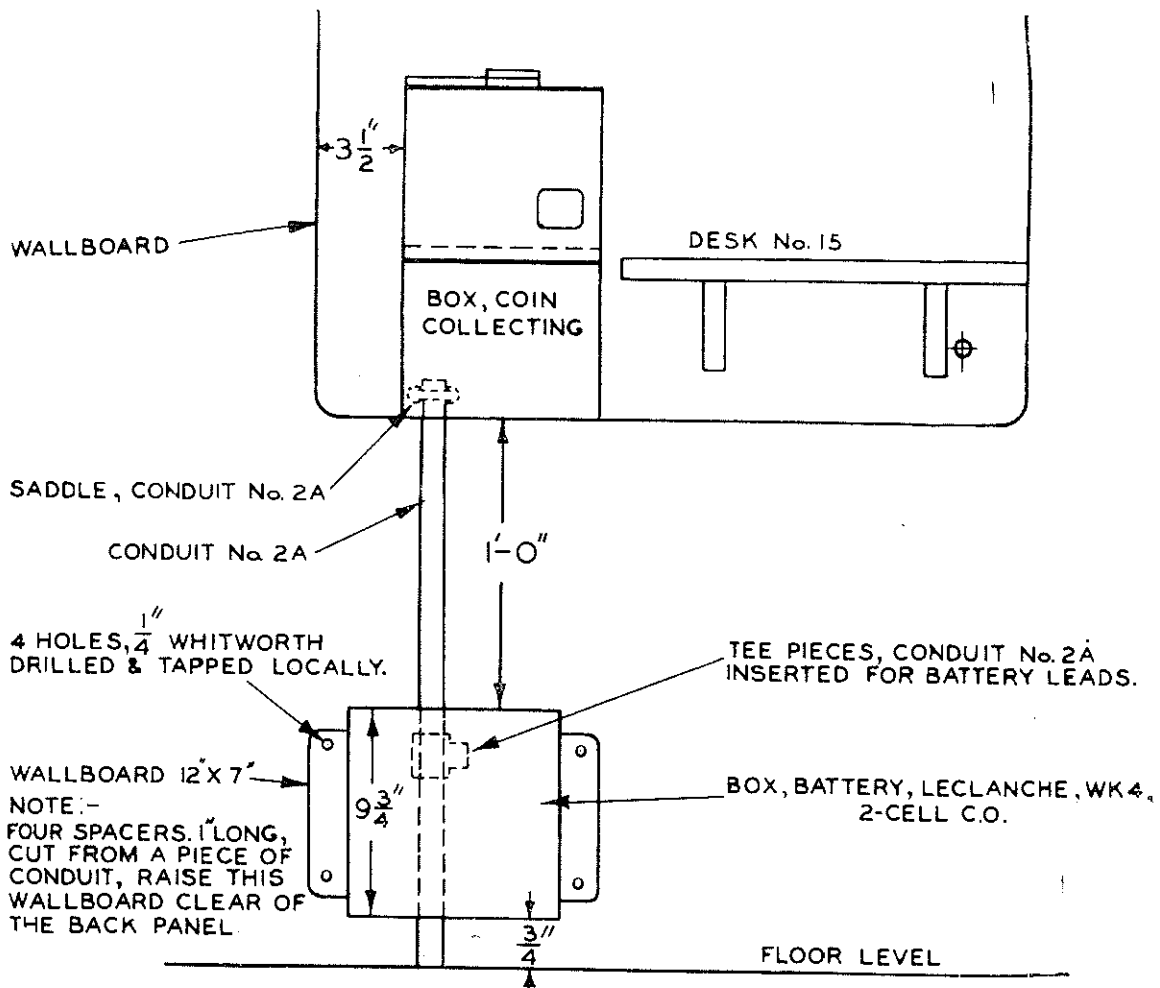

FIG. 4. KIOSKS IN MAGNETO AREAS—LEAD-IN ARRANGEMENTS

it is intended that, normally, the underground services shall be brought in through the floor of the kiosk, these holes are not required. They can, however, be utilized for leading in, if necessary, by removing the 'knock-out' metal web. Care must be exercised when removing the 'knock-out,' otherwise the back panel may be damaged: *a cold chisel and hammer* should be used; *not a hammer only*. The sides of the aperture thus produced will probably need smoothing with a file.

36. *The earth-wire and the telephone lead* should be brought together into the kiosk in the same conduit. At the point where the telephone lead and the earth-wire leave the conduit inside the kiosk, a "Sleeve, Lead, No. 1" should be slipped over them and they should be bonded together by means of a soldered joint, to ensure a good electrical connexion. (*NOTE*:—This only applies where the telephone pair is lead-sheathed.) The free end of the earth-wire should then be soldered into a "Socket, Soldering, No. 8D," and terminated at the earthing bolt provided on the back panel.

A 12-in. length of "Wire F.P., P.V.C., 1 W./12½, Brown or Cream," or its equivalent, should be soldered into the soldering socket with the earth wire. This is for connexion to the terminal of the bell-set which requires earthing. When a protector is to be fitted, a length of "Wire, Copper, Soft, 3/20" must also be soldered into this socket for connexion to the earth terminal of the protector.

37. **Leading-in from overhead distribution** may be adopted when it is uneconomical or impracticable to lead-in from underground. Where it is absolutely necessary to employ the overhead method, the final span of wires must not exceed 25 yards in length and care must be taken to ensure that this span cannot, in any circumstances, be regarded as an obstruction.

38. "Cable, I.R.V., Braided and Compounded" should be used for the leading-in cable, which should be secured in a "Clamp, Drop Wire," attached to a "Bolt 'J'." The 'J' bolt should be fitted in any one of the eight available positions but preference should be given to one of the two positions adjacent to the back panel of the kiosk. To fit the 'J' bolt, withdraw from the inside of the kiosk one of the two screws which secure the Crown panel. Attach the clamp to the 'J' bolt and fit the bolt through the hole from which the screw was withdrawn, screwing the bolt well home, and secure it with the washer and nut provided. Lead in the cable through the ventilator opening and terminate it on the protector in one or other of the following ways, whichever is appropriate:—

(a) Where "Wallboards D1/60577 and D2/60577" are fitted, the I.R.V. cable should be run down behind the wallboard, fed through the cable-entry hole in the left-hand container and then terminated on the protector, see Dgm. EC 1851, or

(b) In magneto areas the I.R.V. cable should be neatly led to the protector which is mounted at the top right-hand side of the wooden wallboard, see Dgm. EC 1852.

39. "Single Kiosk Trailer."—When a kiosk is erected at a central depot, it is best transported to its site by the kiosk trailer which has been designed for this purpose. Fig. 5A shows the kiosk in the loaded position, and Fig. 5B shows it about to be off-loaded. The kiosk can be placed accurately on to the site by careful positioning of the trailer, and it is important that this is done, since attempts to shift the kiosk once it is standing on its base may result in fracture of the cast-iron sill.

40. *When the kiosk and wallboard have been assembled at the depot*, the method of connecting up the telephone lead-in and earth wires is as follows:—

(a) The lead-in cable and earth wire will have been left coiled on the prepared foundation.

(b) The kiosk will be positioned over them so that the piece of conduit projecting from the base is in the correct position relative to the back and side of the kiosk (see Fig. 3A). The height of the conduit must be such that it will project between ½ in. and 1 in. above the floor of the kiosk, when the sill has been filled with concrete.

(c) A draw wire will have been left in place from the mechanism compartment to a point below the edge of the wallboard. This is used to pull the free end of the lead-in cable (over which a "Sleeve, Lead, No. 1" should first be slipped) into the mechanism compartment, ready for connexion to the bell-set. The lead sleeve should be slipped over the free end of the earth wire also, and pushed down to the point where the telephone lead-in and earth wire leave the conduit. [*NOTE*:—The lead sleeve will, of course, be used only where the telephone pair is lead-sheathed.]

(d) A "Wire, Copper, Soft, 3/20" already connected to the earthing bolt of the kiosk, as described in par. 36, will have been left hanging down behind the wallboard. This should be jointed to the earth wire just above the lead sleeve and soldered; spare lengths of both wires should be cut off. The lead sleeve should then be slipped up over the joint and used to bond the earth wire and telephone cable sheath (par. 36).

(e) The sill should now be filled with concrete (par. 32).

(f) When the concrete floor has set, "Capping, Steel, No. 6" should be fastened over the lead-in and earth wires, see Fig. 3B; a gap should not be left at the base of the capping—the slotted fixing holes provide a degree of adjustment to cater for small variations in the level of the floor.

When the telephone line is to be brought in from overhead, a protector will have been fitted; the equipment side of this will have been wired to the bell-set and the earth terminal will have been con-

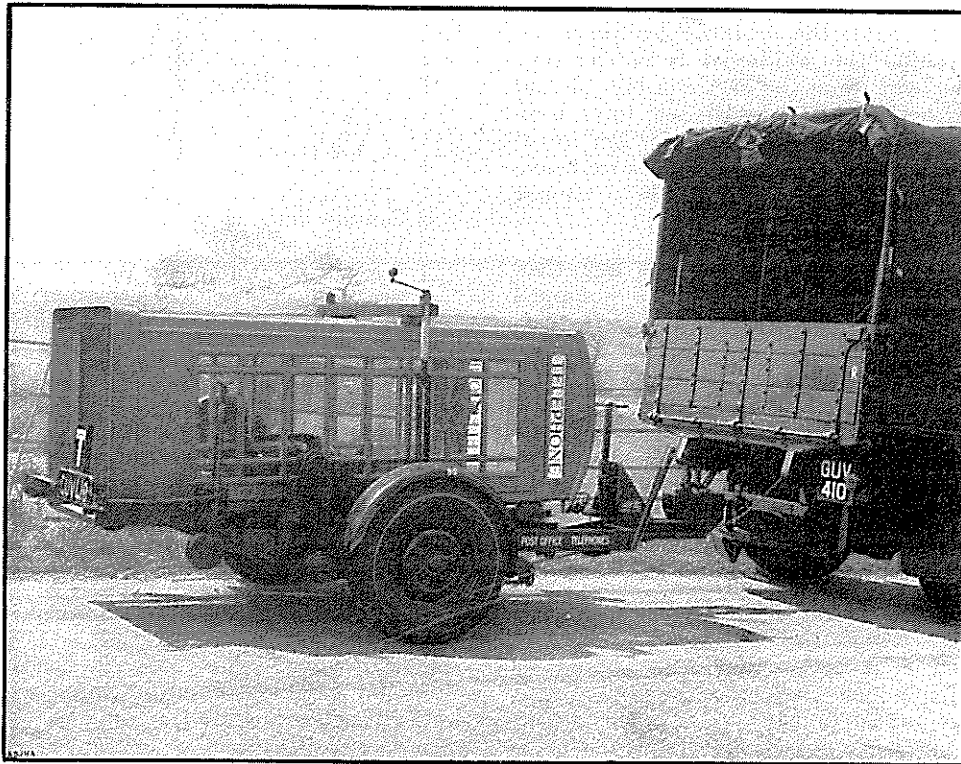

FIG. 5A

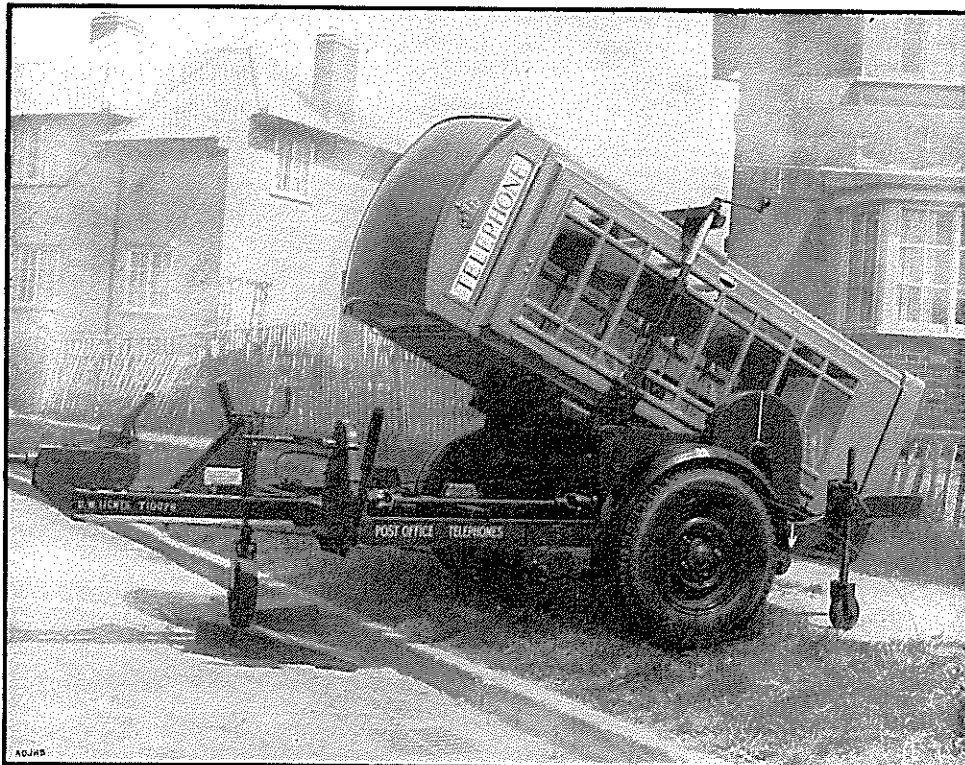

FIG. 5B

nected to the earthing bolt of the kiosk (par. 36). A draw wire will enable the overhead lead-in to be drawn down behind the wallboard from the top. The 3/20 copper wire from the earthing bolt should be soldered to the earth wire which will have been led-in in the standard position. "Capping, Steel, No. 6" should be used to cover the earth wire below the wallboard, and a "Partition D 60967" should be used to cover the protector.

41. Installation of telephone apparatus and electrical equipment etc.—The kiosk will be equipped internally, in accordance with the following Instructions:—

- D 3001—Apparatus
- D 3002—Diagrams
- D 3003—Methods of installation
- A 3006—Instruction cards, Notices etc.

POWER, Lighting, A 3101—Electric lighting of kiosks.

42. Decoration.—See C 3002.

43. Tools.—The following tools are necessary for the erection of "Kiosks No. 6," but some are not normally included in tool kits; these should be obtained by requisition from the Supplies Dept., unless otherwise indicated.

- 1 Tap, Whit., Plug, $\frac{3}{16}$ in.
- 1 " " " $\frac{1}{4}$ in.

References:—A 3006, C 3002, C 5904, D 3001, D 3002, D 3003

TD 104.2 . POWER, Lighting, A 3101
PROTECTION, General, S 3901
STORES, General, F 0018

- 1 Tap, Whit., Plug, $\frac{5}{16}$ in.
- 1 " " " $\frac{3}{8}$ in.
- 1 " " " $\frac{1}{2}$ in.
- 1 " " Taper, $\frac{3}{16}$ in.
- 1 " " " $\frac{1}{4}$ in.
- 1 " " " $\frac{5}{16}$ in.
- 1 " " " $\frac{3}{8}$ in.
- 1 " " " $\frac{1}{2}$ in.
- 2 Tommy bars, $8\frac{1}{2}$ in.
- 2 Vices, Hand, $4\frac{1}{2}$ in.
- 1 Screwdriver, Cabinet, 8 in.
- 1 Brush, Sash, Tool No. 6
- 1 Plumb-bob, $3\frac{1}{2}$ oz.
- 1 Level, Spirit, 10 in.
- 1 Spanner, D.E., $\frac{1}{2}$ in. \times $\frac{5}{8}$ in.
- 1 " " " $\frac{1}{4}$ in. \times $\frac{5}{16}$ in.
- 1 " " $\frac{3}{16}$ in. (Local purchase)
- 1 Brace, Carpenter's
- 1 Bit, Screwdriver, $\frac{1}{2}$ in. } (Local purchase)
- 1 " " " $\frac{5}{16}$ in. }
- 1 " " " $\frac{3}{16}$ in. }
- 1 Chisel, Cold, flat, $\frac{7}{8}$ in. \times 9 in.
- 1 Knife, Putty
- 2 Hammers, Carpenter's, 1 lb.

44. Scaffolding.—The following items will be required and should be hired (or purchased):—

- 2 Trestles
- 2 Step ladders
- 4 Planks.

END