

CALLING LINE IDENTIFICATION

By

*E. J. ROUSSEAU, B.Sc.,
Telephone Development Department.*

To permit On Demand toll service, means must be employed to ascertain the directory number of the calling line in order that the charge for the call may be debited to the correct subscriber. The need to identify a particular line also arises in the event of faulty lines or of malicious calls.

The advantages of automatic methods of calling line identification are described in this article, with special reference to a universally applicable system recently developed by the G.E.C. This system provides immediate display of the calling line number, on a lamp panel or other suitable indicating device, upon the depression of a push button by the operator

In the past, a subscriber requiring a toll call informed the operator of his directory number, either verbally or by dialling. The operator checked the indication by requesting the subscriber to replace his receiver and then calling him again, or by dialling the given number over a special checking train of switches. When identifying a faulty line or tracing a malicious call, the call had to be followed back along the train of switches. Either operation took an appreciable time and not only increased the holding time of the switches or junction but, in the case of toll calls, also caused a considerable reduction in the call handling capacity of the operator.

Various systems of automatic identification have been developed in recent years to overcome these disadvantages. The systems are of two main classes — one for exchanges employing line finders and registers, the other for exchanges with uni-selectors and Strowger selectors.

Systems of the first type are relatively straightforward in conception and operation for, the selecting operation being performed by a line finder,

the identity of the calling line remains and identification of the line finder in use provides indication of the particular group of 100 or 200 lines in which the call is originated. The position of the linefinder will then identify the individual line. A simple hunting operation is therefore sufficient to provide the operator with the number of the calling line.

The identification of the calling line on a uni-selector system presents a more difficult problem than on line finder systems as the preliminary selections, being non-numerical, provide no indication of the origin of the call.

The calling number identification system developed by the G.E.C. has been designed to operate in conjunction with all types of automatic exchanges and may be added to an existing exchange with the minimum of modification. Further advantages of this system are its simple operation, fast and positive identification, non-interference with the normal operation of the exchange and ability to identify calls incoming from a satellite as well as those originated locally.

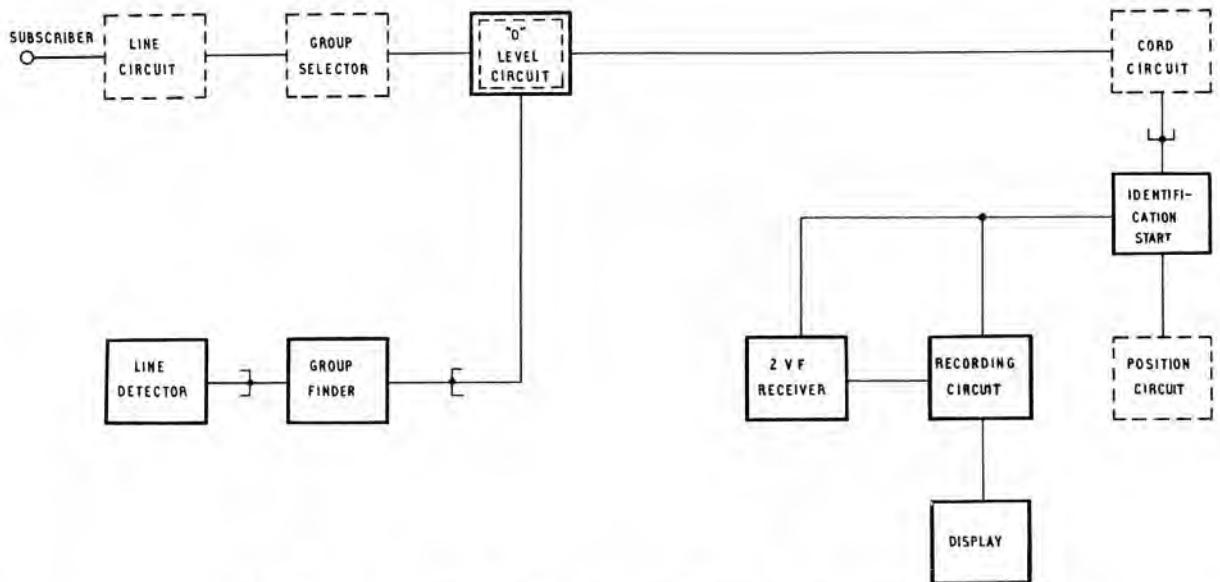

Fig. 1.—Block schematic of line identification system local identification.

The G.E.C. System : General Description

Fig. 1 shows the system in block schematic form, the dotted lines indicate circuits normally in use for the establishment of a call, and the full lines the additional circuits employed for identification.

The system is based on the marking of the *P* wire of the calling line by a 10kc/s signal superimposed on a DC pulse, and the subsequent location of the marked wire.

The lines are grouped into blocks of 100 lines, normally having the same first digits. This grouping has been adopted to simplify the circuits employed and is not essential to the working of the system, which will operate equally well with groups of 100 lines having mixed first digits. Each 100 line group is equipped with a line detector unit incorporating a 10kc/s detector, and all *P* wires in the group are commoned, via non-linear resistance elements, to a group marking relay. The resistance of these elements at the normal operating potential of 50-volts is such that no appreciable current flows through the common point, but application of the DC marking pulse to a *P* wire causes a considerable drop in this resistance and permits the full operating current for the relay to flow

The group marked by the operation of the group marking relay is located by the group finder, a unit common to the whole exchange, which then gives a start signal to the line detector associated with the marked group. The individual line is identified by the line detector unit, upon which the directory number of this line is transmitted over the *P* wire, back to the position circuit, by means of coded impulses of either 600c/s, 750c/s, or a combination of these frequencies. The impulses are received on position recording equipment, where they are translated into appropriate relay combinations and cause the number of the line to be shown on a group of display lamps.

Should the line to be identified be situated at a satellite exchange, or should the manual or toll switchboard be remote from the automatic exchange, the identification marking signal is relayed over the talking wires and an identification operation takes place at the distant exchange as for calls initiated locally. Fig. 2 shows the block schematic covering these conditions.

The system has been described in general terms, but the following points should be noted:—

- (a) The use of a common group finder does not introduce a delay in any of a number of simultaneous identifications. The group finder deals with all start signals given and

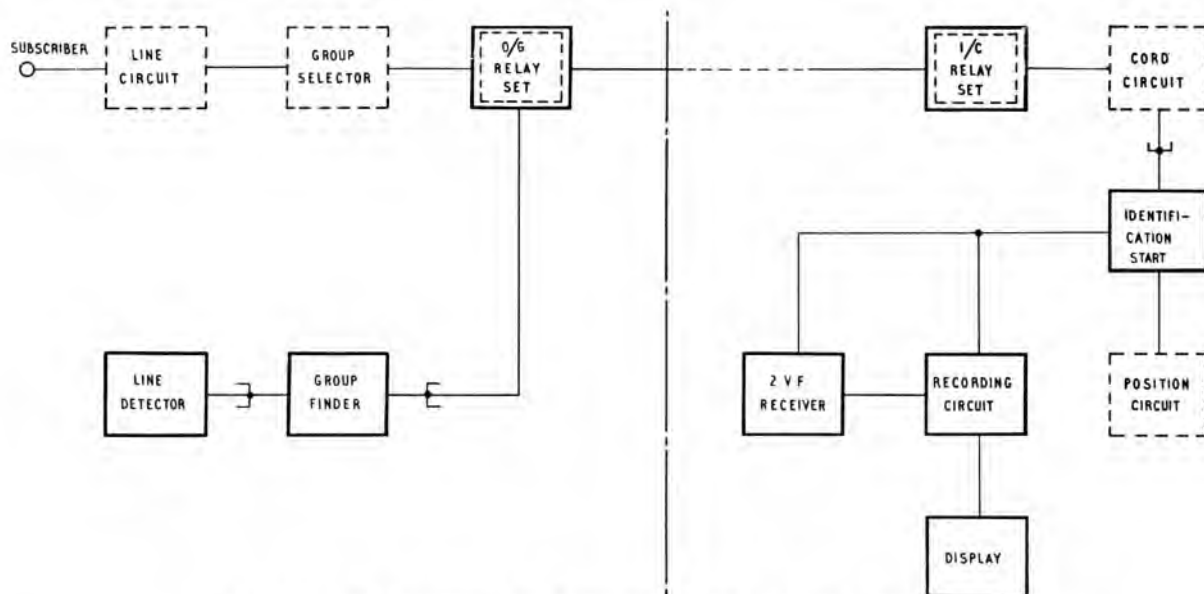

Fig. 2.—Block schematic of line identification system remote identification

will, at any time, cause the starting of all circuits in which a marking signal has been received.

- (b) Although both metering and identification are operated on the *P* wire, the operations are entirely independant. The subscriber's meter is normally operated by a positive pulse but the identification pulse is of too short a duration to allow for energisation of the meter. On the other hand, as the identification marking pulse comprises a positive DC potential with a superimposed 10kc/s AC component, the former being employed to reduce the resistance of the non-linear element in the marking circuit and the latter to operate the marking relay, a normal metering pulse will not cause spurious identification marking.
- (c) The action required on the part of the operator is merely the momentary depression of a key, and the operation of the circuit is independent of the time for which the key is depressed.
- (d) The operator may cancel the identification at any time, or may repeat it if required.
- (e) The average time required to carry out an identification is one and one-quarter seconds, and the maximum time is two seconds.

- (f) As the identification takes place over the actual train of switches used to originate the call, there is no possibility of identifying a line other than the one making the call.
- (g) The group of display lamps normally employed could be replaced by any other suitable form of indicator if desired.

Method of Operation

Fig. 3 shows a simplified schematic diagram of the system.

When a subscriber wishes to make a distant call, connexion is obtained to the manual operator via the line circuit, one or more group selectors, a trunk demand circuit and a cord circuit, to the operator's position circuit.

If the operator wishes to identify the calling line, key ISK is depressed. Relay IC is thereby operated, connecting the incoming talking wires to the 2-V.F receiver and at the same time preparing the recording circuit. Positive battery is now connected to the ring wire via relay ID. The polarised relay IS in the trunk demand circuit is now operated providing connexion of 10kc/s superimposed on 50-volts positive DC to the incoming *P* wire. After a short time, relay ISR operates and dis-

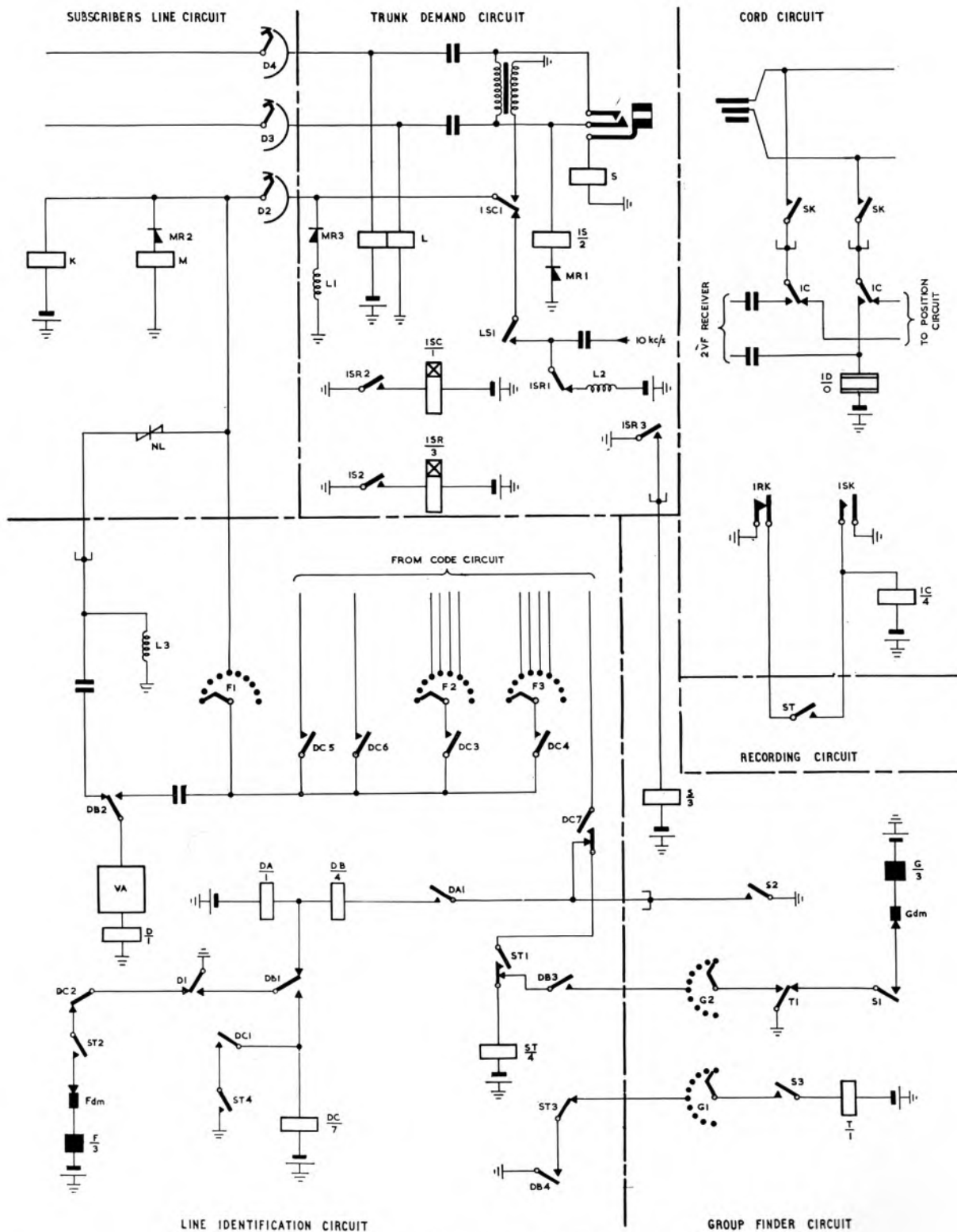

Fig. 3.—Line identification system simplified circuit diagram

connects the positive potential, leaving the 10kc/s potential only connected to the *P* wire. At the same time, relay S in the group finder circuit is operated and the group finder switch G rotates.

In the line identification circuit associated with the group in which the calling line is situated, relay D operates from the marking signal on the *P* wire, in series with the silicon compound unit NL and the 10kc/s detector VA. Relay DA is now operated, preparing a circuit for relay DB from earth in the group finder circuit. This relay is, at the moment, short-circuited by the earth from the contact on relay D. When relay ISR, in the trunk demand circuit, operates, the positive potential is removed from the *P* wire and the silicon compound unit ceases to be conductive. Relay D releases and relay DB is allowed to operate. A circuit is now prepared for relay T in the group finder circuit. When the wipers of the group finder switch reach a terminal corresponding to a marked group (i.e. where relay DB is operated), relay T operates and momentarily stops the switch. A circuit is now completed for relay ST in the marked group over wiper G2 of the group finder. Relay ST locks itself to the common earth from the group finder and at the same time disconnects relay T. Switch G then rotates again, hunting for another marked group.

With relay ST operated, the line detector switch F now rotates and hunts for the individual line. When relay DB operated, relay D and the detector

VA were switched over from the common point of the silicon units associated with the *P* wires, to the wiper F1 of the line detector switch. The individual *P* wires of all lines in the group are connected to the terminals in the arcs of this switch, thus, when the calling line has been found, relay D is again operated from the 10kc/s potential on the *P* wire. Relay DC now operates and connects wipers F2 and F3 to the incoming *P* wire via wiper F1.

In the trunk demand circuit, relay ISC operates after a time calculated to be sufficient to permit the finding of the calling line by the switch F. The *P* wire is now disconnected from the 10kc/s source and connected via a transformer to the talking wires.

According to the position of the wipers F2 and F3, which depends on the calling line, a 2-V.F code corresponding to the directory number of that line is passed to the *P* wire. This code is transmitted, via the *P* wire, the transformer and the talking wires, through the cord circuit, to the 2-V.F receiver. The storing relays in the recording circuit are set according to the code received, and the combinations of contacts on these relays cause the appropriate lamps on the display panel to glow.

When the calling line number has been noted by the operator, the release key IRK is momentarily depressed and the whole equipment is restored to normal.