



Response 125

Userfriendly Guide



Lift flap

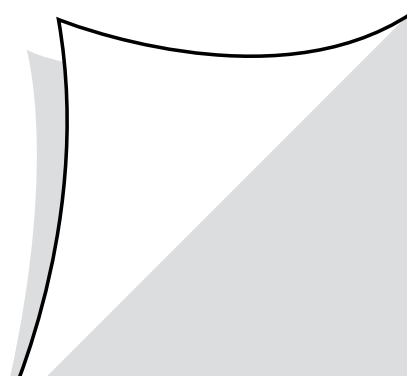

*Please open this page for
an 'At a glance' guide to
your Response 125.*



At a glance

Memory buttons

Use to store and dial one touch telephone numbers.
Page 8

Redial

Press to redial the last number called or to enter a pause in the memory.
Page 9

Store

Use when storing one touch and Quickdial telephone numbers.
Page 8

R

Recall button for use with switchboards and BT Select Services.
Page 10

Memory label

For one touch buttons.

Quickdial

Enables two touch dialling of up to 10 stored numbers.
Page 8,9

Secrecy

Allows you to talk to someone in the same room, without the person on the other end of the line hearing your conversation.
Page 10

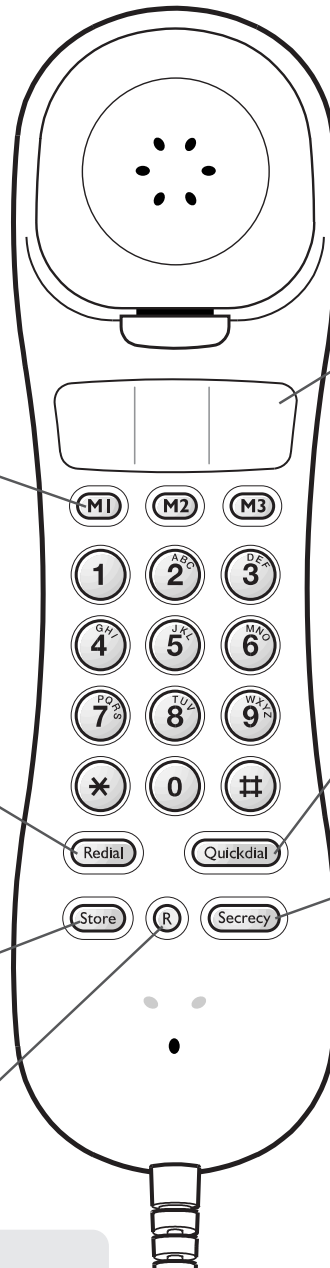

Stop/OGM
Checks your current outgoing message, records a new outgoing message and stops playback of messages.
Page 12

Memory label
For two touch buttons.

Play/Memo/Skip >
Used to play and skip forward through messages and memos, also used to record memos.
Page 13-17

Delete/Time
Deletes messages and sets time and day.
Pages 12,13,14,16,17

Handset park
When wall mounted you can hook the handset on this if you need to temporarily move away from the phone.
Page 26

Handset catch
Retains handset if wall mounted.
Page 26

Answer ON/OFF/Skip <
Switches the answering machine on and off, lets you skip backward through your messages and memos, sets answer delay.
Page 13-16

Battery Low Indicator
Battery low light comes on when either there is no back-up battery in place or the battery is running low.
Page 7

Message Indicator
Lights up when messages have been left.
Pages 12, 14

Microphone
For recording outgoing messages

Volume button
Adjusts the volume for message and memo playback.
Page 11

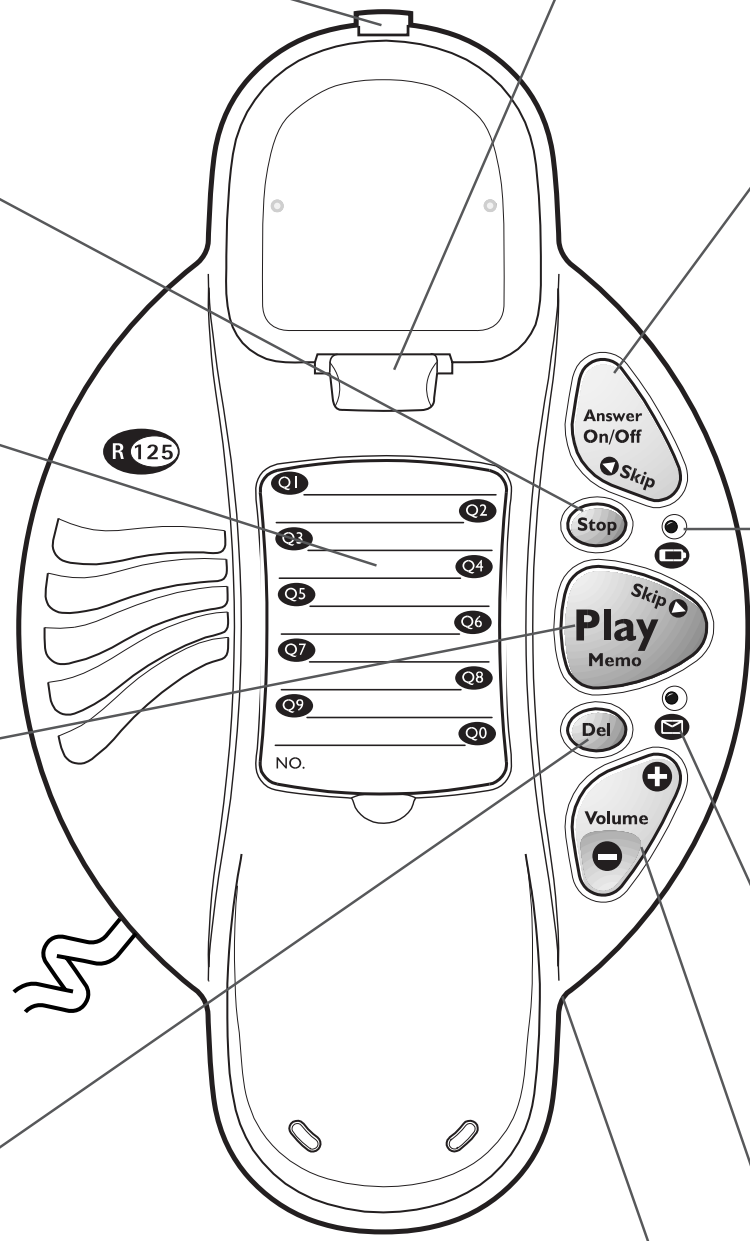



Contents

<i>At a glance</i>	<i>1</i>
<i>Introduction</i>	<i>4</i>
<i>Setting up</i>	<i>5</i>
<i>Using your telephone</i>	<i>8</i>
<i>Using the answering machine</i>	<i>11</i>
<i>Remote access</i>	<i>19</i>
<i>Help</i>	<i>22</i>
<i>Technical information</i>	<i>23</i>
<i>Index</i>	<i>25</i>
<i>Wall-mounting template</i>	<i>26</i>

Hints and tips boxes

In this user guide, we've included helpful tips and useful notes. They are shown in a white box like this.



Introduction

Your Response 125 telephone answering machine is designed for ease of use and made to the high standards set by BT

Thank you for choosing a BT product. You can expect your phone to give you many years of quality service.

Please read the instructions carefully before use, and keep this User Guide for future reference.

For your records

Date of purchase:

.....

Place of purchase:

.....

Serial number:
(on base of answering machine)

.....

Purchase price:

.....

(for warranty purposes, proof of purchase is required, so please keep your receipt)

Customer Helpline

If you have problems with your machine, call the Response 125 Helpline Service, Lo-call 08457 585 589.



Setting up

Follow these steps to get your Response 125 ready to use

IMPORTANT

Check that your Response 125 is complete.

When you unpack you must have:

Response 125 Telephone answering machine with telephone line cord attached

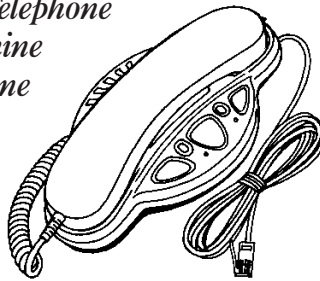

Mains power adaptor plug

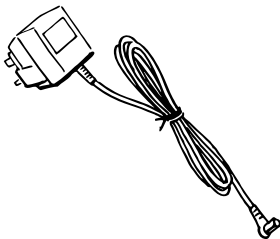

Screws and wall plugs for wall mounting

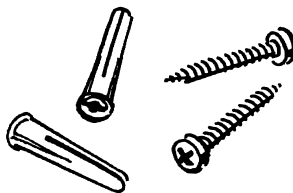

Situating your Response 125

Situate your Response 125 close enough to a mains power socket so that the cables will reach.

Do not cover or enclose the machine; allow a free flow of air to its surfaces.

To wall mount your Response 125, use the screws and wall plugs provided. There is a wall-mounting template at the back of this guide.

Warning

The apparatus is only designed to be operated in a normal office or domestic environment. It should not be used in bathrooms or near water.

Check your telephone wall socket

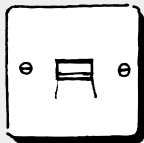

If you do not have a modern-style socket, call **Freefone 0800 800 150** and ask for a BT engineer to come and fit the correct socket.

This is a chargeable service.

Plug your Response 125 telephone line cord into the wall socket

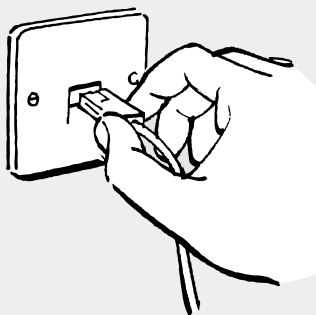

Plug the mains adaptor in the back of the machine

- Place the adaptor cord in the channel provided to prevent it being pulled out accidentally.

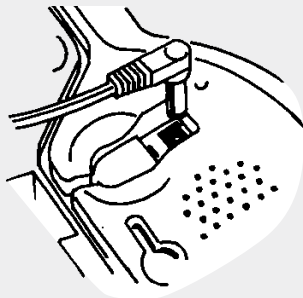

Failure to use the adaptor supplied may result in damage to the product.

Now plug the mains adaptor plug into a convenient mains socket and switch on

- The Message Indicator will flash for 8 seconds.



It will then show the normal 'no messages' display.

Your Response 125 is now ready for use.

Insert back-up battery

BT recommends that you insert an alkaline PP3 9V battery (not supplied) to provide up to 6 hours back-up. This will ensure messages are saved in the event of power failure.

- Place the back-up battery in the compartment under your Response 125 memory label, clip the battery connector cap to the terminals of a PP3 9V battery (not supplied). Replace the cover.

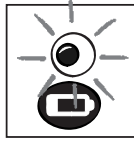
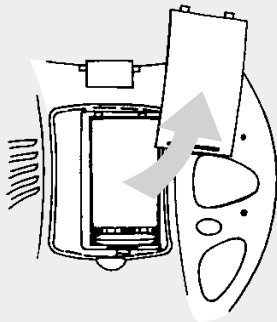

Your Response 125's battery low light comes on when the back-up battery is running low. It also remains lit when no back-up battery is inserted or if the battery compartment is not fully closed.

Set the ringer volume

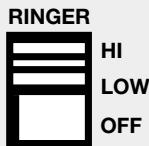

The ringer volume switch is located on the underside of the base unit.

There are 3 settings:

HI - a loud ring: your Response 125 is pre-set to this position.

LOW - a quiet ring.

OFF - no ring

Electrical storm warning

Note 1

During electrical storms, you are advised to disconnect your apparatus because damage may occur.

Note 2

If a fault occurs during the 12-month warranty period and it is due to accidental or wilful damage (including lightning and electrical damage), BT will not replace or repair the equipment free of charge.

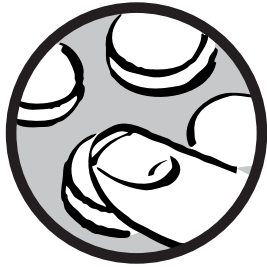

Using the telephone

Storing and dialling numbers

Your Response 125 allows you to store up to 10 telephone numbers in its Quickdial memory. A further three numbers can be stored using one-touch memory buttons **M1**, **M2** or **M3**.

Each stored number can be up to 16 digits long.

To store a telephone number under the memory buttons M1, M2 and M3.

- ① Lift the handset.
- ② Press the **STORE** button.



- ③ Dial the number you want to store.

- ④ Press the **STORE** button again.



- ⑤ Press the memory button (**M1**, **M2** or **M3**) under which you want to store the number.



- ⑥ Replace the handset. The number is stored.

To dial a number stored in the one-touch memory

- ① Lift the handset.
- ② Press the memory button (**M1**, **M2** or **M3**) you want.



- ③ The number is dialled.

To store a telephone number in the Quickdial memory

- ① Lift the handset.
- ② Press the **STORE** button.



- ③ Dial the number you want to store.

- ④ Press the **STORE** button again.



- ⑤ Press the keypad button (**1-0**) under which you want to store the number.

- ⑥ Replace the handset. The number is stored.

To dial a telephone number using the Quickdial memory

- ① Lift the handset.
- ② Press the **QUICKDIAL** button.

- ③ Press the keypad button (1-0) under which the number you want to dial is stored.
- ④ The number is dialled.

To store a telephone number longer than 16 digits

Telephone numbers longer than 16 digits can be stored by putting the first 16 digits in to one memory location (following the same procedure for storing numbers). Then repeat the process, using a different memory location to store the remaining digits.

To dial a telephone number longer than 16 digits

- ① Lift the handset.
- ② Dial the first 16 digits by pressing the **MEMORY** or **QUICKDIAL** button and then the keypad button 0-9 under which the first part of the number is stored.
- ③ Dial the remaining digits by pressing the **MEMORY** or **QUICKDIAL** button and the keypad button 0-9 under which the second part of the number is stored.
- ④ The whole number is dialled.

To change numbers stored in the memory

To change or replace numbers stored in the memory, simply repeat the process for storing numbers (using either the **MEMORY** or **QUICKDIAL** buttons) with the new number.

The new number automatically replaces any existing number stored under that location.

Memory label

Slide out the plastic cover and the memory label. Use a pencil to write in the names belonging to the stored numbers, then you can change them if necessary. Replace the label and cover.

To redial a number

- ① Lift the handset.
- ② Press the **REDIAL** button. The last number called, even a quickdial or memory number, is redialled automatically.

Redial

To store a pause in the memory

Some switchboards and Select Services may require a pause to be entered between an access code and the number to be dialled.

① Pressing the **REDIAL** button will enter a pause.

② To enter a pause when storing a telephone number, press the **REDIAL** button.



When you dial the stored number, your Response 125 will automatically insert the stored pause.

Using the Secrecy button

The **SECRECY** button allows you to talk to someone in the same room whilst on a call, without the person at the other end of the line hearing your conversation.

① During a call, press and hold down the **SECRECY** button. Your caller will not be able to hear you or any conversation being held at your end of the line.



② Release the **SECRECY** button to talk to your caller again.



Using the R (Recall) button

If your Response 125 is connected to a switchboard, the **R** button enables you to use features provided by the switchboards. Please contact your communications manager or switchboard supplier for further details.

The **R** button can also be used in connection with BT Select Services.



If you are connected to a digital exchange, you can subscribe to a range of BT's Select Services. If you wish to subscribe to any of these services, contact BT on **Freefone 0800 800 152** for residential customers

or **Freefone 0800 800 154** for business customers. 8am-6pm, Monday to Friday.

If you are storing the **R** button in the memory, it must be followed by a pause (see 'To store a pause in the memory' page 9).

If your Response 125 is to be used with a switchboard, make sure that the switchboard uses Timed Break Recall.

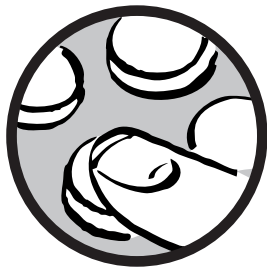

Using the answering machine

To adjust playback volume



- Press + to increase the volume.
- Press - to decrease the volume.

As you press, a beep sounds at the level you have selected. When the volume is at its highest or lowest, you will hear two beeps.



If you adjust the volume during playback, the beep does not sound, but the volume changes accordingly.

If you set the volume below mid-level, it will automatically return to its middle setting when any buttons are pressed on the answering machine. The volume is unaffected during remote access or call screening.

To record your outgoing message

The outgoing message is the message a caller hears when your Response 125 answers a call.

The Response 125 has a pre-recorded outgoing message which announces...

Hello, your call cannot be taken at the moment, so please leave your message after the tone.

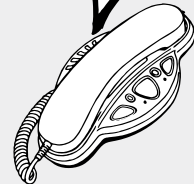

You can record your own outgoing message to replace the pre-recorded message. If you record your own message, the pre-recorded message will automatically be removed and stored in the memory in case you wish to reinstate it.

Your Response 125 has a total recording capacity of 14 minutes. Any outgoing message you record can be up to 2 minutes long, but you should keep it short to allow more time for recording incoming calls.

To record your outgoing message, speak clearly, 15 to 20 cm from the built-in microphone.

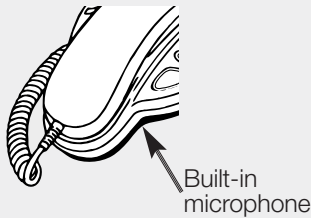

Read all the steps before you begin recording.

- 1 Press and hold down the stop button.



Your Response 125 will beep and the message indicator flashes.



- 2 Keep holding down the **STOP** button and speak your message into the microphone. Located on the right-hand side of the base near the end of the handset.



When you have finished speaking, release the **STOP** button.

Your Response 125 will automatically play back your message, then beep to confirm the recording. It then returns to 'answer on' mode.

To re-record your outgoing message, repeat these steps.

To check your outgoing message

Press and release the **STOP** button



Your Response 125 will beep and play back your outgoing message. It will then beep again and return to 'answer on' mode.

To delete your outgoing message

You can delete your outgoing message and reinstate the pre-recorded outgoing message.

- 1 Press and release the **STOP** button. Your outgoing message will be played back to you.



- 2 While the message is playing, press the **DELETE** button.



Your Response 125 will beep and play its pre-recorded outgoing message.



Your own message has now been replaced by the original, pre-recorded message.

To check the day and time setting

Press and release the **DELETE** button.



The currently set day and time is announced.

To set the correct day and time

Your Response 125 will announce the day and time that an incoming message or memo was recorded.

- 1 Press and hold down the **DELETE** button. Your Response 125 will announce the day currently set.



- 2 Still holding down the **DELETE** button, press either the **SKIP** button to move backwards through the days of the week, or the **SKIP** button to move forwards.



or



- 3 When you hear the correct day, release the **DELETE** button. Your Response 125 will announce the day you have set.



You can now set the current hour

- 1 Press and hold down the **DELETE** button.



Your Response 125 announces the hour currently set.



- 2 Still holding down the **DELETE** button, press either the **SKIP** button to move backwards through the hours, or the **SKIP** button to move forwards.

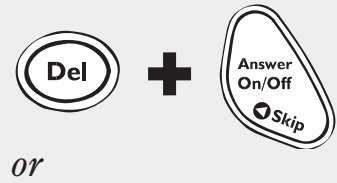

or



The time on your Response 125 is announced using the 12 hour clock. Be sure to hold down the < or > buttons long enough for your Response 125 to say whether it is AM or PM.

- 3 When you hear the correct hour, release the **DELETE** button.



Your Response 125 announces the hour you have set.

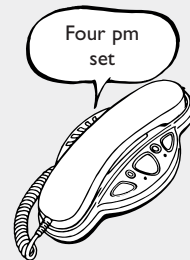

You can now set the current minute

- 1 Press and hold down the **DELETE** button.



Your Response 125 announces the currently set minute.

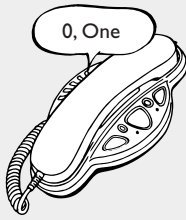

- ② Still holding down the **DELETE** button, press either the **◀ SKIP** button to move backwards through the minutes, or the **SKIP ▶** button to move forwards.



or



- ③ When you hear the correct minute, release the **DELETE** button.



Your Response 125 announces the day and time you have set.

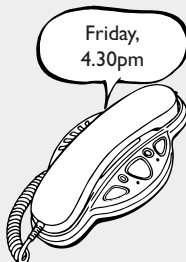

After setting the time and day, your machine will automatically return to 'answer on' mode.

To switch the answering machine on and off

- ① Press the **ANSWER ON/OFF** button. Your Response 125 announces...



- ② Press the **ANSWER ON/OFF** button again. The machine announces...



The display will flash when messages are recorded in the memory.

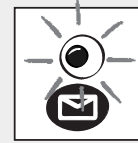

To check the answer delay setting

Press and hold the **ANSWER ON/OFF** button. When the current delay setting is announced release the button.



To set the answer delay

Answer delay sets the number of times your Response 125 will ring before answering a call.

Time saver

Your Response 125 is pre-set to **TIME SAVER**. This means that during remote access, if any messages have been recorded your Response 125 will answer after only 2 rings. If there are no messages, it will answer after 6 rings, thereby allowing you the option of hanging up before your Response 125 answers, to avoid paying for the call.



When you hear the setting you want, release the **ANSWER ON/OFF** button. After 2 seconds the new answer delay setting is announced, before your Response 125 returns to 'answer on' mode.

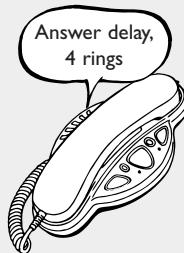

Two minutes is the maximum time available for each incoming message. If the maximum message length is reached, your Response 125 announces "Thank you for calling" and disconnects the line. If the memory is full, then it will announce, "Memory full, thank you for calling" and disconnects the line.

Your Response 125 has a recording capacity of up to 14 minutes. If the recording memory is full, the LED flashes rapidly and your answering machine will not record further messages.

- 1 Press and hold down the **ANSWER ON/OFF** button. Your Response 125 will announce the current answer delay setting.



- 2 Keep holding down the **ANSWER ON/OFF** button. Your Response 125 announces the answer delay options...



To receive incoming messages

Your Response 125 will automatically record an incoming message when it is connected to your phone socket and is set to 'answer on'.

When your Response 125 has received new messages, the display light flashes.

To play back messages

Press the **PLAY** button. Your Response 125 announces





The messages are then played back, each one has an announcement of the day and time it was received.



Messages are played back in the order they were received.

When in 'answer on' mode, the display flashes to indicate you have messages.

When all your messages have been played back, your Response 125 announces...



To skip forward or backward through your messages

When playing back messages, you can skip forward to the next message or backward to the start of the current message and previous messages.

- 1 Press the **SKIP** ► button. Your Response 125 announces 'Message one' and play the first message



While the message is playing...

- 2 Press the **SKIP** ► button to skip forward to the start of the next message.



- 3 Press the ◀ **SKIP** button once to return to the start of the current message.



- 4 Press the ◀ **SKIP** button *twice* to go to the start of the previous message



To delete individual messages

- 1 Press the **PLAY** button to play your messages.



- 2 When the message you want to delete is playing, press the **DELETE** button.



Your Response 125 announces...



Repeat the procedure to delete any further messages.

When you have finished deleting and your Response 125 has finished playing all messages, you will hear 'End of messages'. If you press the **STOP** button within 8 seconds of hearing this message, you can cancel all deletions and retain all your messages.

If you accidentally delete all messages, you can still save them provided you press the **STOP** button within 8 seconds of the announcement 'end of messages'.

- 3 Speak clearly into the built-in microphone.

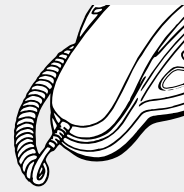

Built-in microphone

- 4 When you have completed recording your memo, release the **PLAY/MEMO** button. You hear a confirmation beep. Your memo is now stored.

To delete all messages

To record a memo

A personal memo can be recorded on your Response 125 and left as a message for another user. Memos can be of any length, up to the maximum recording capacity of 14 minutes.

Your Response 125 treats memos in the same way as incoming messages.

To play back, delete or skip forward and backward through memos, follow the instructions for playing back messages, on pages 15 and 16

- When your Response 125 has finished playing all messages, you will hear 'End of messages'. If you press the **DELETE** button within 8 seconds your Response 125 will announce...



Your Response 125 now returns to 'answer on' mode.

Read all the steps before you begin recording.

- 1 Press and hold the **PLAY/MEMO** button.



- 2 You hear a beep.



To use call screening

Your Response 125 can answer an incoming call for you, allowing you to identify the caller and decide whether to take the call.

- ① Make sure that the volume is set to an audible level. (See 'To adjust the volume', page 11)
- ② Allow the incoming call to be answered by your Response 125 as normal. You will hear the caller begin to leave their message.
- ③ If you decide to take the call, lift the handset and you can speak to the caller. Recording will stop automatically.

*If, when you lift the telephone handset, your Response 125 does not stop recording, either replace the handset and lift again, or press the **STOP** button.*

To cancel any procedure

Pressing the **STOP** button will cancel any procedure currently in progress.



After pressing the button your Response 125 returns to 'answer on' mode.

These functions of the Response 125 will not operate whilst the handset is off the base unit:

- *Volume control.*
- *Checking/recording/deleting outgoing message.*
- *Checking and setting day and time.*
- *Switching answering machine on/off.*
- *Checking and setting answer delay.*
- *Recording a memo.*

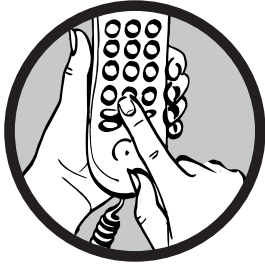

Remote access

Control your Response 125 from another telephone using a Touchtone™ keypad.

You can turn your Response 125 answering machine on, and listen to your messages from any Touchtone™ telephone. To protect your privacy, messages can only be accessed by keying in a 2 digit security code.

For your security code, look on the underside of your Response 125's base unit. (You cannot change the currently set code).

To check for messages

- ① Dial your phone number and wait.
- ② When you hear your outgoing message, press the ★ button. You hear 2 beeps.



- ③ Enter the first digit of your security code. You hear a beep.
- ④ Enter the second digit of your security code, If you have no messages, you will hear 'You have no messages. Thank you for calling'.

...and your Response 125 will disconnect the line.

If you have messages, you hear...



Your Response 125 will then play your messages, with the day and time they were recorded.

If you hear 4 short beeps, it means you have entered the wrong security code and are invited to try again. Do not re-enter ★.

If you take more than 8 seconds to enter a number, you hear 'Thank you for calling' and your Response 125 disconnects the line.

To replay the message you are listening to

While the message is playing, press 4 once on your telephone keypad



The message will replay from the beginning.

To replay all your messages

Press **2** on your telephone keypad within 8 seconds of hearing the announcement '*End of messages*'.



All messages are replayed.

To skip back to a previous message

While a message is playing, press **4** twice to go back to the previous message or press it three times to move back two messages.



You can skip back over any number of messages by pressing the **4** button.

To skip forward to the next message

While a message is playing, press **6**. The next message is played.



You can skip forward two messages by pressing the **6** button twice, or press it three times to skip forward three messages.

To delete the message you are listening to

While listening to the message, press the **5** button.



You hear the announcement '*Message deleted*'.

To delete all recorded messages

You can delete all messages immediately after listening to the final message.



Press the **5** button within 8 seconds of hearing '*End of messages*'.

All messages will be deleted. Your Response 125 announces '*All messages deleted*'.

To turn your Response 125 on from another telephone

If you go out and forget to switch on your answering machine, you can turn it on remotely, using any other phone.

Dial your phone number and wait. Your Response 125 will automatically answer after 20 rings. It will now stay switched on.

If the memory is full, you have to delete some of your messages before your Response 125 will switch to 'answer on' mode. After you hear the 'Memory full' announcement, you have 8 seconds to enter your security code. You can then delete messages. (See 'To delete messages' page 20.)



Help

If you have a problem, the following simple solutions may provide the answer

No dialling tone

Make sure your telephone line cord is plugged into the phone socket.

Phone does not ring

Check that the ringer volume switch (on the base) is *not* set to off.

Do you have too many phones in your home?

Please see 'How many phones can you have?' in the Technical Information section for details about the number of phones you can use.

No indicator light appears

Is the power cord plugged in to the back of your Response 125?

Is the mains power adaptor plugged in and switched on?

Display continually flashing

This indicates an error. Press any button on your answering machine. Flashing should stop and the answering machine should reset to its original settings. Unplug the line cord and mains power cord. Wait 5 minutes and then replug.

Battery low indicator is on

The back-up battery is low in power, missing or incorrectly installed. Remove the memory label and open the battery compartment. If the battery is fitted correctly, try replacing it with a new PP3 9V alkaline battery. When operating at normal level, the battery light remains off.

You experience a power cut

Back up will only occur if a battery is fitted, and will only last approximately 6 hours. All its settings and messages should be saved until power resumes. However, it will not be able to record any new messages during the power cut.

You cannot hear messages or incoming calls

The speaker volume may be set too low. Adjust it by pressing + on the volume control.



Buzzing noises on the answering machine

Your answering machine is too close to a radio, TV, computer, cordless or mobile telephone, causing interference. Move it another metre away.



Technical information

Environment

Your Response 125 should be kept free of dust, moisture, high temperature and vibration, and should not be exposed to direct sunlight. Do not stand it on carpets or other surfaces which generate fibres, or place it in locations which prevent the free flow of air over its surfaces.

Warning

The apparatus is only designed to be operated in a normal office or domestic environment where the relative humidity does not exceed 75%. It should not be used in bathrooms or near water.

If the power fails

If the battery warning light was off when the power was lost, all information should be retained for at least 1 hour (up to 6 hours for a fresh alkaline battery).

If the light was on, data may be lost even if a back-up battery was installed.

If no battery was installed, all information will be lost and the Response 125 will power up as new when power is restored.

How many phones can you have?

All items of telephone equipment have a Ringer Equivalence Number (REN), which is used to calculate the number of items that may be connected

to any one telephone line. Your Response 125 has a REN of 1. Any other instrument provided by BT may be assumed to have a REN of 1 unless stated otherwise. A total REN of 4 is allowed. (For example: if your Response 125 is used in conjunction with three extension telephones, each with a REN of 1, the total REN is 4).

If the total REN of 4 is exceeded, the telephones may not ring. With different telephone types there is no guarantee of ringing, even when the REN is less than 4.

Customer Helpline

If you have problems with your machine, call the Response 125 Helpline Service, Lo-call 08457 585 589.

Connection information

Your Response 125 may be connected to public networks in the United Kingdom.

It may also be connected to switching systems that use tone (MF) signalling, with timed break recall. If in doubt, your switchboard supplier or maintainer should be able to offer help. Advice on connection to BT switching systems can be obtained by dialling BT **Freefone 0800 800 152**.

If you do not have a compatible switchboard, it cannot be guaranteed that your Response 125 will operate correctly under all possible conditions of connection.

Guarantee

○ *If you own your Response 125 – under BT's guarantee.*

BT guarantees the product for one year provided that:

- The goods have only been used for their intended purpose, and have not been misused, or been wilfully or accidentally damaged.
- The goods have not been tampered with or repaired by anyone except BT, its staff or agents. If a fault does occur in this product, and you bought the unit yourself, provided that you return it to the place of purchase and produce your receipt, it will either be repaired or replaced free of charge. The terms and conditions of this guarantee do not affect your statutory rights.

○ *If you own your Response 125 – outside guarantee.*

If your Response 125 needs repair after the guarantee period has ended, it must be repaired so that it continues to comply with the approval requirements for connection to the telephone network. We recommend that you call BT free, **Freefone 0800 800 150**, or visit your nearest BT shop, and you will be informed of our recommended repair agents.

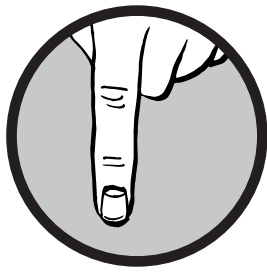

Index

Answer delay	14,15
At a glance	1
Battery	
inserting	7
warning	7
Call screening	18
Cancel any procedure	18
Day and time	
check	12
set	13,14
Dial numbers	8,9
Guarantee	24
Help	22
Helpline	4,23
Incoming message	
deleting all	17
delete individual	16
playback	15,16
receive messages	15
skip backward	16
skip forward	16
Mains adaptor	6
Memo	17
Memory buttons	
storing	8
dialling	8

Messages	
checking	12
deleting	12
record outgoing	11
On/off	14
Pause	9,10
Playback volume	11
Quickdial memory	
changing numbers	9
dial	9
storing	8
numbers longer than 16 digits	9
Recall	10
Redial a number	9
Remote access	
check messages	19
delete	20
on	20,21
skip backward	20
skip forward	20
turn your Response 125	
on from another telephone	20,21
replay messages	19,20
Ringer volume	7
Secrecy	10

Setting up	5
Stop	18
Storing numbers	8,9
Technical information	23,24
Telephone wall socket	6
Time saver	15
Using the answer machine	11
Using the telephone	7
Volume	11
Wall mounting template	26
Warning	23

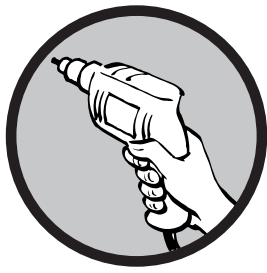

Wall-mounting

Your Response 125 can be wall-mounted using the screws and wall plugs provided.

Use the wall-mounting template opposite as a guide for the drill holes.

Before you wall-mount your Response 125, check that:

- the wall can support the weight of the phone;
- the position you choose leaves sufficient space so that the phone is clear of any obstruction on the wall, such as a shelf or cupboard.

Drill two holes for the screws and insert the wall plugs provided (if required).

Drive the screws into the wall, leaving about 4mm free on which to hang the phone.

Press the phone line cable into the channel on the bottom of the phone, so that the phone lies flat against the wall.

Hang the holes on the back of the phone over the screwheads and gently pull the phone downward to make sure it is securely in place.

Rotate the handset hook 180°, so that you can hang up the handset when the phone is wall-mounted.

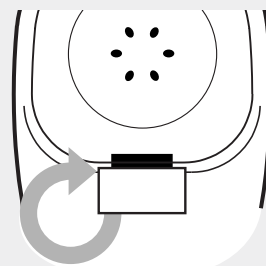
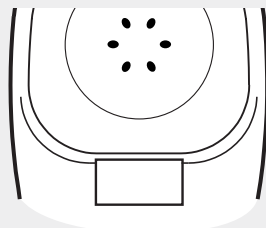

Wall-mounting template

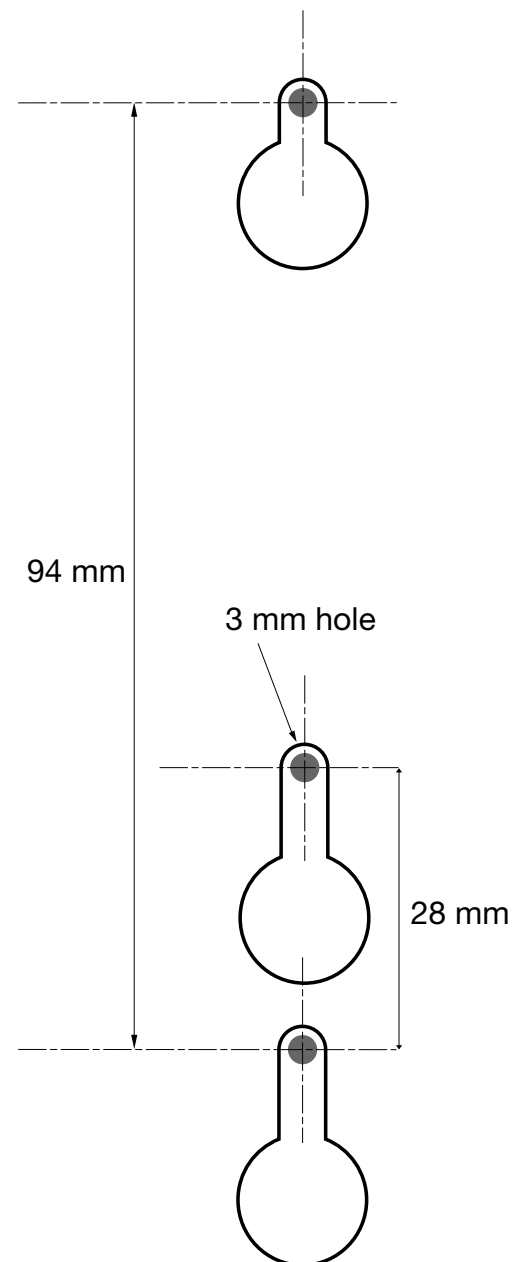



*Offices in Europe, North America,
Japan and Asia Pacific.*

The Telecommunications services described in this publication are subject to availability and may be modified from time to time. Services and equipment are provided subject to British Telecommunications plc's respective standard conditions of contract. Nothing in this publication forms any part of any contract.

Touchtone[™] is a registered trade mark of British Telecommunications plc in the UK.

©British Telecommunications plc 1999.
Registered Office: 81 Newgate Street, London EC1A 7AJ.
Registered in England No. 1800000.
Printed in China. Response 125 Issue No.1 (4/99). 6
Designed by The Art & Design Partnership Limited.



CE compliant to 89/336/EEC
(EMC Directive) & 73/23/EEC
(Low Voltage Directive)

APPROVED for connection to
telecommunication systems specified
in the instructions for use subject to
the conditions set out in them.

504638