



# *Response 15+*

**Digital Answering Machine**

# User Guide

This product is intended for connection to analogue public switched telephone networks and private switchboards in the United Kingdom.

**Please open this page for an 'at a glance' guide to your Response 15 Plus.**



# At a glance

## Answer on off

Switches the answering machine on and off. Also lets you set the number of rings before calls are answered.

## ◀ Skip

Skips backwards through your messages during playback.

## Microphone

For recording your outgoing message or memo.

## Message Counter

Indicates when the machine is on or off, the number of messages that have been left or when the memory is full.

## Volume – +

Adjusts the volume of message playback, OGM and voice prompts.

## Battery Low

Lights up if the battery is not installed or the back-up battery needs replacing.

## Stop

Use to record and check your personal outgoing message.

Stops message playback, recording of memos and your outgoing message.

## Delete

Lets you delete individual messages or all messages. Also lets you set and check the day and time.

## Play

Lets you play back messages. Also lets you record a memo message.

## Skip ▶

Skips forward through your messages during playback.

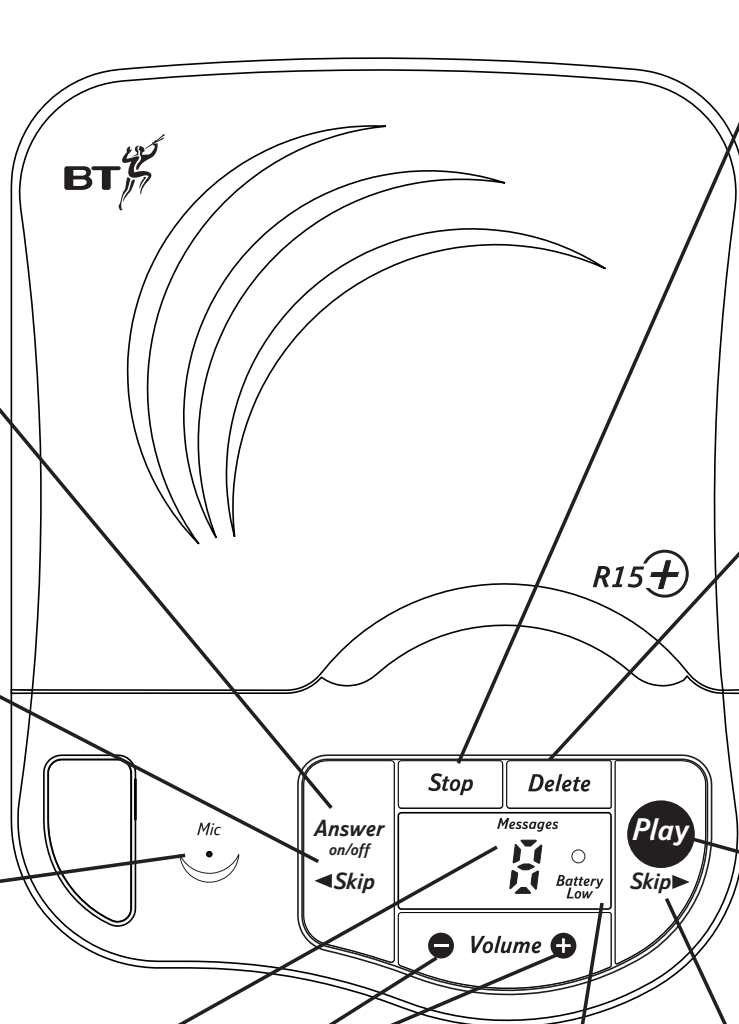

## Note

*On the underside of the unit you will find a quick reference guide which you can swing out, giving you instructions on some of the products most useful features.*

# Key features

## 18 minutes recording capacity

Offers the benefits of digital recording.

## Message counter

Allows you to see if the machine is on or off, how many messages have been left, or when the memory is full.

## 8 step electronic volume control

Lets you set the loudspeaker volume for message playback, outgoing message and voice prompts.

## Remote access

You can ring your Response 15 Plus from another phone and switch it on or operate it to play back your messages.

## Time & day stamp

Announces the time and day each message was received.

## Answer delay

Allows you to set the number of rings before calls are answered.

## Time saver

You can set your Response 15 Plus so that it will answer after 2 rings if messages have been left. If there are no new messages it will answer after 6 rings. During remote access this allows you to hang up before your Response 15 Plus answers, therefore avoiding the cost of a call.

## Call screening

You can hear who's calling you through the loudspeaker and decide whether to answer the call in person or let your Response 15 Plus record a message.

## Voice prompts

Helps you to follow instructions more easily.

# *In this guide*

<b><i>At a glance</i></b>	<b>1</b>
<b><i>Key features</i></b>	<b>2</b>
<b><i>Introduction</i></b>	<b>4</b>
<b><i>Setting up</i></b>	<b>5</b>
<b><i>Safety instructions</i></b>	<b>7</b>
<b><i>Using your Response 15 Plus</i></b>	<b>8</b>
<i>Answer machine controls</i>	8
<i>Outgoing message (OGM)</i>	9
<i>Receiving messages</i>	11
<i>Call screening</i>	13
<b><i>Remote access</i></b>	<b>14</b>
<i>Your security code</i>	14
<i>Menu for remote access</i>	15
<b><i>Help</i></b>	<b>16</b>
<i>Guide to the display</i>	18
<b><i>General information</i></b>	<b>19</b>
<i>Guarantee</i>	19
<i>Technical information</i>	20
<i>Switchboard compatibility</i>	20
<i>Wall mounting template</i>	21
<b><i>Index</i></b>	<b>23</b>

## **Please note**

*In this user guide we have included helpful tips and useful notes. They are shown in a white box like this.*

# Introduction

Your Response 15 Plus has been designed for ease of use and made to the high standards set by BT

You can expect your Response 15 Plus to give you many years of trouble-free service.

Please read the instructions carefully before use and keep this User Guide for future reference.

## Unpacking your Response 15 Plus

If anything is missing, please contact your place of purchase immediately.

- Response 15 Plus digital answering machine

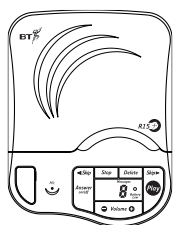

- Plug mounted, 13 amp mains adaptor

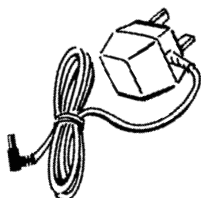

- Screws and wall plugs for wall mounting



## For your records

Date of purchase:

Place of purchase:

Serial number (on the underside of the unit):

Purchase price:

For warranty purposes, proof of purchase is required, so please keep your receipt.

Keep a reference of your Remote access Security Code here:

See Using Remote access, page 14.

# Setting up

Follow these steps to set up your Response 15 Plus ready for use

## Plan the location of your Response 15 Plus

Situate your Response 15 Plus close enough to the phone and mains power sockets so that both cables will reach.

### 1 Check your telephone wall socket

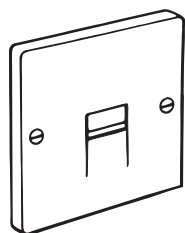

If you do not have a modern phone socket, call **Freephone 0800 800 150** and ask for a BT engineer to come and fit the correct socket. This is a chargeable service.

### 2 Plug the mains power cord into the back of the machine

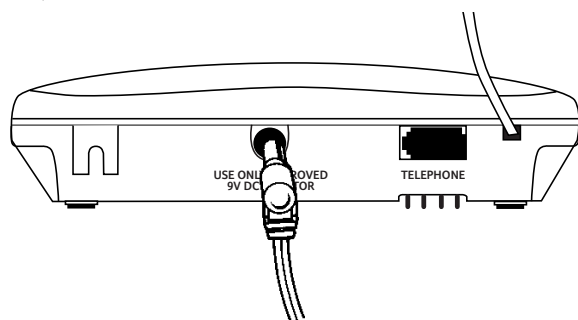

### 3 Plug the adaptor into a mains power socket

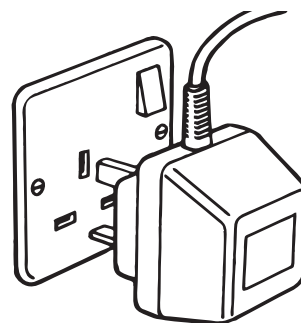

The display will flash for 20 seconds. It will then show the normal 'no messages' display. The display will flash slowly until any button is pressed.

### 4 Insert the back-up battery

Before inserting the back-up battery you must ensure that your unit is connected to the mains power.

BT recommends that you insert an alkaline PP3 9V battery (not supplied) to provide up to 6 hours back-up. This will ensure messages are saved in the event of power failure.

Place the back-up battery in the compartment on the underside of your Response 15 Plus.

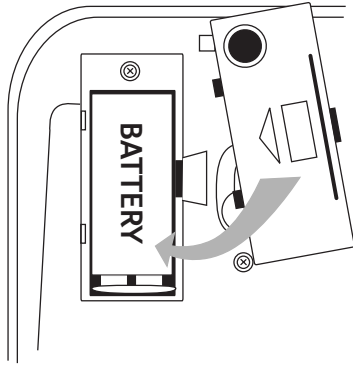

**Please note**

*Your Response 15 Plus battery low light, located beside the display, indicates back-up battery strength.*

*The LED will light up when the battery is low. It also remains lit when no back-up battery is inserted.*

**5 Plug your Response 15 Plus into the telephone socket**

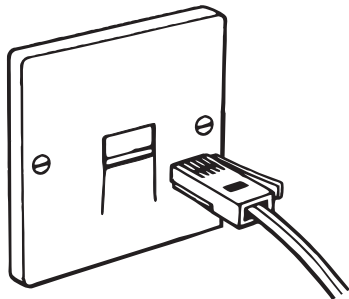

**6 You can now plug your telephone into your Response 15 Plus**

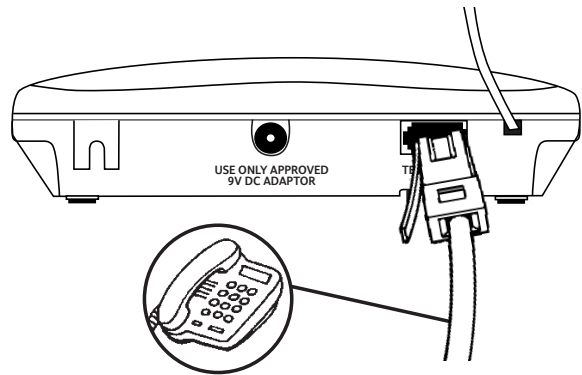

You will now be able to use your telephone as normal.

Your Response 15 Plus is now ready to use.

**7 Wall mounting your Response 15 Plus**

Use the template on page 21 to drill holes in the wall. Leave a small gap between the screw heads and the wall.

Place your Response 15 Plus over the screw heads and slide down.

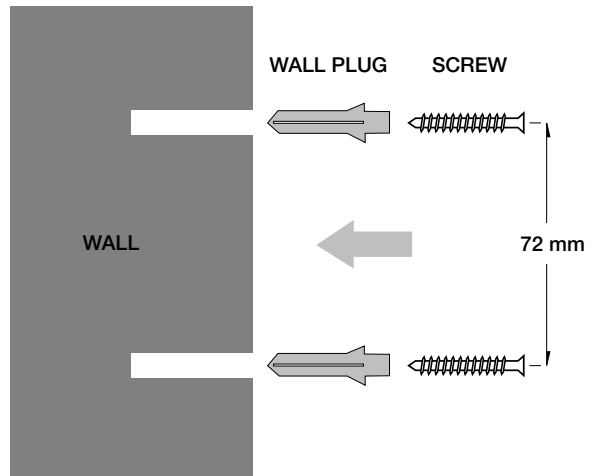

# *Safety instructions*

## **General**

- Simply clean your Response 15 Plus with a damp (not wet) cloth, or an antistatic wipe. Never use household polish as this may damage the product. Never use a dry cloth as this may cause static shock.
- Only use the power supply included with the product. Using an unauthorised power supply unit will invalidate your guarantee and may damage the answer machine. The item number for the power supply unit is **872300**.
- Do not open the Response 15 Plus. This could expose you to high voltages or other risks.
- This product should not be used near emergency/intensive care medical equipment and should not be used by people with pacemakers.
- Never dispose of batteries in a fire. There is a serious risk of explosion and/or the release of highly toxic chemicals.

## **Environmental**

- Do not expose to direct sunlight.
- The product may heat up. This is normal. However, we recommend that you do not place the product on antique/veneered wood to avoid damage.
- Do not stand your product on carpets or other surfaces which generate fibres, or place it in locations preventing free flow of air over its surfaces.
- Do not submerge any part of your product in water and do not use it in damp or humid conditions, such as in bathrooms.
- Do not expose your product to fire, explosive or other hazardous conditions.
- There is a slight chance that your phone could be damaged by an electrical storm. We recommend that you unplug the power and telephone line cord for the duration of the storm, as damage is not covered by the guarantee.

# Using your Response 15 Plus

## Answering machine controls

### To switch the answering machine on and off

*Press buttons in the order shown.*

**Answer  
on/off**

Press and release the **Answer on/off** button. Your Response 15 Plus will announce 'Answer off.'

When off, the display shows a single dash.

**Answer  
on/off**

Press and release the **Answer on/off** button again. Your Response 15 Plus will announce 'Answer on.'

When on, the display shows the number of messages received e.g 5.

### To adjust the loudspeaker volume

You can adjust the volume of your outgoing message, incoming message, memos and voice prompts.

There are 8 levels to choose from. The default level is mid-range.

**Volume** **+**

Press **+** to increase the volume.

**Volume** **-**

Press **-** to decrease the volume.

As you press, a beep sounds at the level you are selecting. When the volume is at its highest or lowest level you will hear 2 beeps.

### Please note

*If you alter the volume during playback of a message, the beep does not sound but the volume will change accordingly. If the volume is set to below mid-volume, it will automatically return to the mid-volume setting when any buttons are pressed (for example, if a message is played back). The volume is unaffected during remote access or call screening.*

### To set the day and time

Your Response 15 Plus will announce the day and time an incoming message or memo was recorded.

#### To check the day and time

**Delete**

Press and release the **Delete** button. Your Response 15 Plus announces the day and time in hours and minutes.

**Delete****To set the day**

Press and hold the **Delete** button. Your Response 15 Plus will announce the current day.

**Skip▶****◀Skip**

Still pressing the **Delete** button, press either the **Skip▶** button or the **◀Skip** button to move forwards or backwards through the days of the week. When you hear the correct day, release the **Delete** button. Your Response 15 Plus will announce the day you have set.

**Delete****To set the hour**

Press and hold the **Delete** button again. Your Response 15 Plus will announce the hour currently set.

**Skip▶****◀Skip**

Still pressing the **Delete** button, press either the **Skip▶** button or the **◀Skip** button to move forwards or backwards through the hours.

When you hear the correct hour, release the **Delete** button. Your Response 15 Plus will announce the hour you have set.

**Please note**

*The time on your Response 15 Plus is announced using the 12-hour clock. Be sure to hold down the ◀ or ▶ buttons long enough for your machine to say whether it is am or pm.*

**Delete****To set the minute**

Press and hold the **Delete** button again. Your Response 15 Plus will announce the minute currently set.

**Skip▶****◀Skip**

Still pressing the **Delete** button, press either the **Skip▶** button or the **◀Skip** button to move forwards or backwards through the minutes. When you hear the correct minute, release the **Delete** button.

Your Response 15 Plus will announce the new day and time setting and then return automatically to 'answer on' mode.

**Outgoing message (OGM)**

The outgoing message is the message a caller hears when your Response 15 Plus answers a call.

Your Response 15 Plus comes with a pre-recorded outgoing message. *'Hello, your call cannot be taken at the moment, so please leave your message after the tone.'*

You can use this outgoing message or you may prefer to record your own. To hear the outgoing message press the **Stop** button.

**Please note**

*Your Response 15 Plus has a total recording capacity of 18 minutes. Any outgoing message you record can be up to 2 minutes long, but you should keep it short to allow more time for recording incoming calls.*

## To record your outgoing message

You can record your own outgoing message to replace the pre-recorded message. If you record your own message, the pre-recorded message will be automatically removed and stored in the memory, in case you wish to reinstate it.

### Please note

*Your outgoing message may sound something like this: 'Hello, I'm sorry I can't take your call at present. If you would like to leave a message, please speak after the tone.'*

To record your outgoing message speak clearly 15–20cm from the in-built microphone.

Read all the steps before you begin recording.

**Stop**

Press and hold the **Stop** button. Your Response 15 Plus will beep and display 'r'.

Keep holding down the **Stop** button and speak your message into the microphone.

When you have finished speaking, release the **Stop** button. Your Response 15 Plus will beep, play back your message, then beep to confirm the recording. It will then return to 'answer on' mode.

To re-record your message repeat this procedure.

## To check your outgoing message

**Stop**

Press and release the **Stop** button.

Your Response 15 Plus will beep and play back your outgoing message. It will then beep again and return to 'answer on' mode.

## To delete your outgoing message

You can delete your outgoing message and return to the Response 15 Plus' pre-recorded outgoing message.

**Stop**

Press and release the **Stop** button. Your outgoing message will be played back to you.

During playback of your outgoing message press the **Delete** button.

**Delete**

Your Response 15 Plus will beep and play its pre-recorded outgoing message.

Your own message has now been replaced by the Response 15 Plus' original pre-recorded outgoing message.

## Call counter

The counter will display the number of messages that have been recorded in the memory.

If you have received 10 or more messages the display will flash  to indicate this. See page 18 for a guide to the display.

## To set the answer delay

Answer delay sets the number of times your Response 15 Plus will ring before answering a call.

Your Response 15 Plus' answer delay is pre-set to 4 rings. You can choose between 2-9 rings or Time Saver.

### Time Saver

*Your Response 15 Plus can be set to Time Saver mode. This means that during remote access, if any messages have been recorded your Response 15 Plus will answer after only 2 rings. If there are no messages, it will answer after 6 rings, thereby allowing you the option of hanging up before your Response 15 Plus answers, to avoid the cost of a call.*

**Answer  
on/off**

Press and hold the **Answer on/off** button. Your Response 15 Plus will announce the current answer delay: 'Answer delay 4 rings.'

Keep holding the **Answer on/off** button. Your Response 15 Plus

will announce the answer delay options and display the number of rings.

When you hear your desired setting, release the **Answer on/off** button. After 2 seconds your Response 15 Plus will announce the new answer delay setting and then return to 'answer on' mode.

## To check the answer delay setting

**Answer  
on/off**

Press and hold the **Answer on/off** button. Your Response 15 Plus will announce and display the current answer delay setting.

## Receiving messages

Your Response 15 Plus will automatically record an incoming message when it is connected to your phone socket and set to 'answer on'.

When your Response 15 Plus has received new messages, the message counter will display the number of messages you have received.

### Please note

*Two minutes is the maximum time allowed for each incoming message. If the maximum message length is reached, your Response 15 Plus will announce 'Thank you for calling' and disconnect the line.*

### Note

*Your Response 15 Plus has a total recording time of 18 minutes. If the memory capacity becomes full, the message indicator will display 'F' and your Response 15 Plus will go into 'answer off' mode. Callers will hear the announcement 'Memory full, thank you for calling' and the line will be disconnected.*

### To play back messages and memos

**Play**

Press the **Play** button. Your Response 15 Plus will announce *'You have x messages. Message one:'* The message will then be played back with an announcement of the day and time it was received.

If you have more than one message, messages will be played back in the order in which they were received.

When all your messages have been played back, your Response 15 Plus announces *'End of messages'*.

When playing back messages, you can skip forward to the next message or backward to the start of the current message (or previous message).

**Skip▶**

Press the **Skip▶** button to skip forwards to the start of the next message.

**◀Skip**

Press the **◀Skip** button once to return to the start of the current message.

**◀Skip**

Press the **◀Skip** button *twice* to return to the start of the previous message.

### To delete individual messages

**Delete**

*During playback of the message:* Press the **Delete** button.

Your Response 15 Plus will announce *'Message deleted'*.

If you wish to cancel the deletion of individual messages, at the end of all message play back the display shows an 8 second countdown. During this time press the **Stop** button. The messages selected for deletion will be saved.

**Stop**

### To delete all messages

**Delete**

Following play back of all your messages, your Response 15 Plus will count down from 8 to 0. During this time you can delete all stored messages.

Now press the **Delete** button within the 8 second countdown. Your Response 15 Plus will announce, *'All messages deleted'*.

**Stop**

If you wish to cancel the deletion, press the **Stop** button within the 8 second countdown. Your Response 15 Plus will return to 'answer on' mode.

## To record a memo message

A personal memo can be recorded on your Response 15 Plus and left as a message for another user. Memos can be of any length, up to a maximum recording capacity (18 minutes), but you should keep them short to allow time for recording incoming messages.

Read all the steps before you begin recording.

**Play**

Press *and hold* the **Play** button. Your Response 15 Plus will beep and display 'r' to indicate recording has begun.

Speak clearly into the in-built microphone.

When you have completed your memo, release the **Play** button. Your Response 15 Plus will beep again. Your memo is now stored and can be played back as if it were an incoming message.

*To play back, delete or skip forward or backward through memos follow the instructions for playing back messages. (page 12).*

## Call screening

Your Response 15 Plus can answer a call for you, allowing you to identify the caller and decide whether to take the call.

Make sure the volume is set to an audible level. (*See page 8*).

When the phone rings, let your Response 15 Plus answer the call and wait until the caller begins to leave a message.

If you decide to take the call, pick up your handset and speak. Recording will stop automatically.

*If, when you lift the telephone handset, your Response 15 Plus does not stop recording, either replace the handset and lift again, or press the **Stop** button. Pressing **Stop** gives the announcement 'Thank you for calling'.*

## To cancel any procedure

**Stop**

Pressing the **Stop** button will cancel any procedure currently in progress.

After pressing **Stop**, your Response 15 Plus will return to 'answer on' mode.

# Remote access

You can switch on and operate your Response 15 Plus from another TouchTone phone to play back your messages and memos

## Your security code

To help keep your messages private, your Response 15 Plus requires you to enter a 2-digit Security Code before you can play back your messages.

For your security code, look at the swing out label on the underside of the machine. (You cannot change the security code).

## To check for messages

Dial your Response 15 Plus phone number.

KEYPAD

When you hear your outgoing message, press the ★ button. You will hear 2 beeps.

The message counter on your Response 15 Plus will flash 'M'.

KEYPAD

Key in the first digit of your security code (within 8 seconds).

KEYPAD

Key in the second digit of your security code.

### Please note

*You will hear 4 short beeps if you have entered the wrong security code and are invited to enter the code again. Do not re-enter ★. You are allowed 2 attempts.*

*If you take more than 8 seconds to enter a number, the Response 15 Plus will announce 'Thank you for calling' and disconnect the line.*

If you have no messages, you will hear... *'You have no messages. Thank you for calling.'* ... and your Response 15 Plus will disconnect the line.

If you have messages you will hear... *'You have x messages.'* Your Response 15 Plus will then play your messages, with the day and time they were recorded.

## To switch your Response 15 Plus on

This is useful if you forgot to switch on your answering machine before going out.

KEYPAD

Ring your Response 15 Plus phone number. After 20 rings your Response 15 Plus will answer. When you hang-up, the answering machine will be switched on and will answer calls.

### Please note

*If the memory is full, you will have to delete some messages before your Response 15 Plus will switch to 'answer on' mode.*

*After you hear the 'memory full' announcement, you have 8 seconds to enter your security code. You can then delete messages, see 'To delete messages', page 15.*

### Menu for remote access

You can now playback, and access various other remote functions using the phones keypad, as follows:

#### To repeat current message

During message playback:

**KEYPAD** Press the **4** button.

#### To replay all messages

When you hear "End of messages", within 8 seconds, press **2** on your keypad.

**KEYPAD**

#### To skip backwards to the previous message

During message playback:

**KEYPAD** Press the **4** button twice to skip back to the previous message, or three times to move back 2 messages, etc.

#### To skip forwards to the next message

During message playback:

**KEYPAD** Press the **6** button.

You can move forward two messages by pressing the **6** button twice, move forward 3 messages by pressing it 3 times, and so on.

#### To delete the current message

During message playback:

**KEYPAD** Press the **5** button.

Your Response 15 Plus will announce "Message deleted".

#### To delete all messages

When you hear "End of messages", within 8 seconds, press **5** on your keypad.

**KEYPAD**

Your Response 15 Plus will announce "All messages deleted".

# Help

If you have any problems using your Response 15 Plus, this section gives you the most common solutions

## **Call counter does not light up**

Check that your Response 15 Plus is correctly connected to the mains and that the power cable is inserted correctly into the back of your Response 15 Plus.

If you have inserted the back-up battery before connecting to the mains power you will need to reset your Response 15 Plus.

## **No dial tone on the telephone**

Is the telephone cord plugged into the back of the Response 15 Plus unit?

Is the Response 15 Plus cord plugged into the wall socket?

## **Response 15 Plus' display is flashing continuously**

This indicates an error. Press any button on your answering machine. Flashing should stop and the answering machine should reset to its settings on first 'power up'. Unplug the line cord and power cord. Wait 5 minutes and then replug.

## **Response 15 Plus' battery low indicator is on**

The back-up battery is either low in power, missing or incorrectly installed. Open the battery compartment which is located on the underside of the unit. If the battery is correctly in place, try replacing it with a new 9V alkaline battery. When operating at normal power the battery light remains off.

## **You experience a power cut**

If a working battery is installed inside your answering machine, its settings and messages should be saved until power resumes. It will not be able to record any new messages, however.

## **You cannot hear messages or incoming calls**

Your Response 15 Plus' volume may be set too low. Adjust the volume by pressing **+** on the volume control.

## **Buzzing noise on answer machine**

Your answering machine is too close to a radio, TV, computer, cordless or mobile telephone, causing interference. Move it another metre away.

## **Incoming message does not record**

Make sure your Response 15 Plus is set to answer-on mode and that the memory is not full. When the memory is full, the display will flash F.

## **You cannot access remotely**

Make sure that the telephone you are using to access your Response 15 Plus has a *TouchTone*<sup>™</sup> keypad.

When entering your code, make sure you allow enough time, at least 2 seconds, between digits for your Response 15 Plus to recognise each one.

**To reset**

If you encounter a problem and your Response 15 Plus will not respond to any button presses, remove the battery then turn off the power for 10 seconds. Turning the power back on will reset your Response 15 Plus to answer-on mode.

Ensure that your Response 15 Plus is connected to the mains power before you insert the back-up battery.

All messages will be lost when resetting your Response 15 Plus.

## Guide to the display

Response 15 Plus	Message counter display shows
Power off	
Power up or reset (about 8 seconds)	☰ (flashing)
Power on – answer-off mode	–
Answer-on mode – no messages – after reset	(flashing slowly), then 1 to 9 (according to number of messages recorded following reset) until a button is pressed
Answer-on mode, 0-9 messages – normal use	0 to 9
Answer-on mode, more than 9 messages	9 (flashing)
Message recording (memo, outgoing message or incoming message)	r (flashing)
Remote access in progress	⌘ (flashing)
Memory full	F (flashing rapidly)
Setting or reading Answer delay	t or 2 to 9
Error	E (flashing rapidly)

# General information

## Guarantee

Your Response 15 Plus is guaranteed for a period of 12 months from the date of purchase.

Subject to the terms listed below the guarantee will provide for the repair of, or at BT's or its agent's discretion the option to replace the Response 15 Plus, or any component thereof, (other than batteries), which is identified as faulty or below standard, or as a result of inferior workmanship or materials.

### **The conditions of this guarantee are:**

- The guarantee shall only apply to defects that occur within the 12 month guarantee period.
- Proof of purchase is provided.
- The equipment is returned to BT or its agent as instructed.
- This guarantee does not cover any faults or defects caused by accidents, misuse, fair wear and tear, neglect, tampering with the equipment, or any attempt at adjustment or repair other than through approved agents.
- This guarantee does not affect your statutory rights.

### **Within the 12 month guarantee period:**

If you experience difficulty using the product, prior to returning your product, please read the Help section beginning on page 16.

In the unlikely event of a defect occurring, please return the product, with the receipt, to the place of purchase.

### **Outside of the 12 month guarantee period:**

If your product needs repair after the guarantee period has ended, the repair must meet the approval requirements for connection to the telephone network. We recommend that you contact BT's approved repair agent, TecLogic on **01672 564444** or a local qualified repairer.

## If you have to return your Response 15 Plus

Pack the unit securely, preferably in the original packaging. All parts must be returned including the mains power adaptor. We cannot take responsibility for goods damaged in transit.

## Technical information

### How many telephones can you have?

All items of telephone equipment have a Ringer Equivalence Number (REN), which is used to calculate the number of items which may be connected to any one telephone line. Your Response 15 Plus has a REN of 1. A total REN of 4 is allowed, if the total REN of 4 is exceeded, the telephones may not ring. With different telephone types there is no guarantee of ringing, even when the REN is less than 4.

Only use approved power supply, item code 872300.

This equipment complies with the essential requirement of the Radio Equipment and Telecommunications Terminal Equipment Directive, 1999/5/E.

## Switchboard compatibility

This product is intended for use within the UK for connection to the public telephone network and compatible switchboards, which support tone dialling and time break recall. If in doubt please consult your service provider.

### WARNING

*The apparatus is only designed to be operated in a normal office or domestic environment where the relative humidity does not exceed 60%. It should not be used in bathrooms or near water.*

## Connection information

The Response 15 Plus is intended to be connected to analogue networks and private switching systems in the United Kingdom.

It may also be connected to switching systems that use tone (MF) or pulse (LD) signalling, with earth or timed break recall. If in doubt, your switch supplier or maintainer should be able to offer help. Advice on connection to BT switching systems can be obtained by dialling BT **Freefone 0800 800 152**.

If you do not have a compatible switchboard, it cannot be guaranteed that your Response 15 Plus will operate correctly under all possible conditions of connection.

## If the power fails

If the battery warning light was not lit before the power was lost, all information should be retained for at least one hour (up to 6 hours for a fresh alkaline battery)

If the light was on, data may be lost even if a back-up battery was installed.

If no battery was installed, all information will be lost and the Response 15 Plus will power up as new when power is restored.

## Wall mounting template

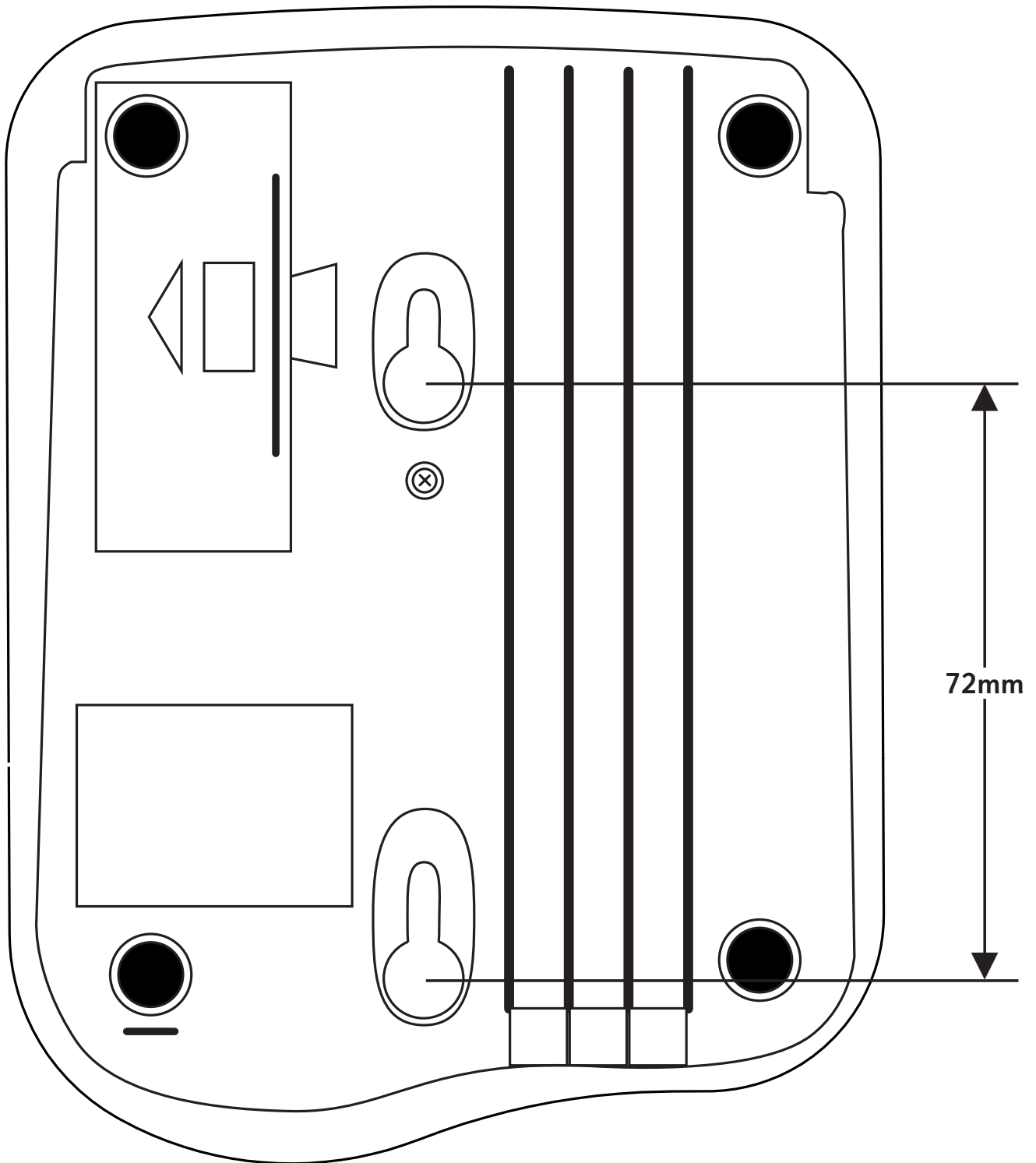



# Index

<b>A</b>			
Answer delay	11	<b>O</b> n/off	
Answering machine		answering machine	8
loudspeaker volume	8	Outgoing messages	9
on/off	8	check your outgoing message	10
outgoing message	9	delete your outgoing message	10
receiving messages	11	record your outgoing message	10
At a glance	1	<b>P</b> layback	12
<b>B</b> attery	6	<b>R</b> eceiving messages	11
<b>C</b> all counter	11	<b>R</b> ecord	
Call screening	13	memo	13
Cancel a procedure	13	outgoing message	10
<b>D</b> ay/time setting	8	Remote access	14
Delete		check for messages	14
all messages	12	menu	15
individual messages	12	security code	14
Display guide	18	switch on remotely	14
<b>G</b> eneral information	19	Returning your Response 15 Plus	19
Guarantee	19	Ringer Equivalence Number	20
<b>H</b> elp	16	<b>S</b> afety instructions	7
<b>M</b> ains power cord	5	Security code	14
Mains power socket	5	Setting up	5
Memory full	12	Switchboard compatibility	20
Memos	12	<b>T</b> echnical information	20
Messages		Telephone line socket	5
delete all	12	Time/day setting	8
delete individual	12	<b>U</b> npacking	4
memos	13	<b>V</b> olume loudspeaker	8
outgoing	9	<b>W</b> all mounting	6
playback messages/memos	12	Wall mounting template	21
record a memo	13		
stop	13		



## Offices worldwide

The telecommunications services described in this publication are subject to availability and may be modified from time to time. Services and equipment are provided subject to British Telecommunications plc's respective standard conditions of contract. Nothing in this publication forms any part of any contract.

*Touchtone*<sup>™</sup> is a registered trade mark of British Telecommunications plc in the UK.

© British Telecommunications plc 2000.  
Registered Office: 81 Newgate Street, London EC1A 7AJ.  
Registered in England No. 1800000.  
Designed by: The Art & Design Partnership Limited.  
Printed in China. Response 15 Plus. Issue 1 (10/00) 5

