

LONDON 12 PABX

SYSTEM MANUAL

EDITION 1

LONDON 12 PABX

SYSTEM MANUAL

EDITION 1

CONTENTS

SECTION 1 : SYSTEM DESCRIPTION

SECTION 2 : INSTALLATION GUIDE

SECTION 3 : PROGRAMMING GUIDE

SECTION 4 : USER GUIDE

SECTION 5 : MAINTENANCE

ISSUE STATUS

Page No.	Issue No.	Page No.	Issue No.	Page No.	Issue No.
A1	2				
A2	2				
1.1	1	3.1	4a	5.1	1
1.2	1	3.2	4a	5.2	1
1.3	1	3.3	4a	5.3	1
1.4	1	3.4	4a	5.4	1
1.5	1	3.5	4a	5.5	1
1.6	1	3.6	4a	5.6	1
1.7	1	3.7	4a	5.7	1
1.8	1	3.8	4a		
1.9	1	3.9	4a		
1.10	1	3.10	4a		
1.11	1	3.11	4a		
		3.12	4a		
		3.13	4a		
		3.14	4a		
		3.15	4a		
		3.16	4a		
		3.17	4a		
		3.18	4a		
2.1	3	4.1	4a		
2.2	3	4.2	4a		
2.3	3	4.3	4a		
2.4	3	4.4	4a		
2.5	3	4.5	4a		
2.6	3	4.6	4a		
2.7	3	4.7	4a		
2.8	3	4.8	4a		
2.9	3	4.9	4a		
2.10	3	4.10	4a		
2.11	3	4.11	4a		
2.12	3	4.12	4a		
2.13	3	4.13	4a		
2.14	3	4.14	4a		
2.15	3	4.15	4a		
2.16	1	4.16	4a		
		4.17	4a	Drawings	
		4.18	4a	SS12E007	3
		4.19	4a	SS12G011	2
		4.20	4a	SS12G012	2

CHECK ISSUE NUMBERS AND DESTROY ANY OBSOLETE INFORMATION

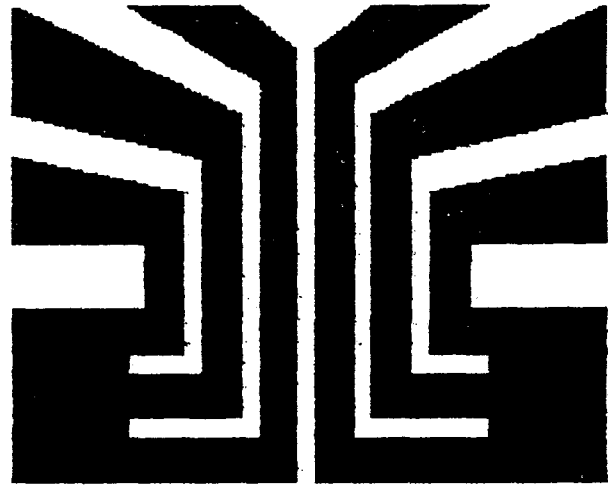

small systems engineering

SECTION 1 SYSTEM DESCRIPTION

CONTENTS

	Page
SECTION 1 : SYSTEM DESCRIPTION	
1.1 General Description	1.2
1.2 Technical Overview	1.3
1.2.1 Introduction	1.3
1.2.2 Processor	1.3
1.2.3 Tone Generator	1.4
1.2.4 Printer Interface	1.4
1.2.5 Shift Register Interface	1.4
1.2.6 Battery Backup	1.4
1.2.7 Watchdog Circuit	1.5
1.2.8 Crosspoint Matrix	1.5
1.2.9 Shift Registers	1.6
1.2.10 Tone Decoders	1.7
1.2.11 Line Interfaces	1.7
1.3 Outside Line Interfaces	1.8
1.3.1 Ring Detection	1.8
1.3.2 Dialling	1.9
1.3.3 Clear Detection	1.9
1.4 Extension Interfaces	1.10
1.4.1 Dialling	1.10
1.4.2 Ringing	1.11
1.5 Ring Generator	1.11
1.6 Power Supplies	1.11

DRAWINGS

SS12E007	Extension Line Interface Circuit
SS12G011	System Component Identification Diagram
SS12G012	System Block Diagram

SECTION 1 SYSTEM DESCRIPTION

1.1 GENERAL DESCRIPTION

The LONDON 12 is a stored program control (SPC) small PABX which operates in the "Simple Call Routing Mode". The system utilises microprocessor control and solid state switching. The system may be operated with telephones approved to BS 6317. The LONDON 12 employs the "Loop Calling Unguarded Clearing" method of signalling to the PSTN.

The system is supplied in four different configurations depending on line configuration and whether MF dialling is required. Information specifying the configuration is contained in the system model number.

If the MF option is installed extension telephones may be either MF (with timed break recall) or Loop Disconnect.

Call logging is provided via a V24 port enabling the use of a 9600 baud printer or terminal.

Visual indication of PABX activity (ie external or internal call in progress) is provided by an LED mounted on the central control unit.

Power fail fall back facilities are provided. In the event of a power failure extension telephones 21 and 22 (and 23 on the 3+9 version) are automatically connected to exchange lines 1,2 (and 3).

Internal battery back-up is provided for the LONDON 12 RAM so that stored telephone numbers and other programable information is retained in the event of a power failure.

Power requirements are provided from the AC mains. Interconnection between the central control unit and the extension telephone sockets is via a T/JF/MDF mounted on the unit (1 pair of wires per extension). Feed current for extensions is provided from the unit's internal power supply.

The unit is housed in a cabinet which can be wall or desk mounted.

1.2 TECHNICAL OVERVIEW

1.2.1 INTRODUCTION

The LONDON 12 is a small electronic PABX. It may be configured to have either 3 external lines and 9 extensions or 2 external lines and 10 extensions. Signalling may be by either the 'Loop Disconnect' (Decatic) method or by using DTMF 'Touchtones'. These options and others, may be selected by means of configuring switches prior to power up. A number of the options available may be selected by dialling certain codes from the master extension. The PABX is controlled by a microprocessor, and may be connected to a printer for call logging and/or diagnostic purposes. Switching is achieved using CMOS analogue switches ("Transmission Gates").

The PABX circuitry consists of the following three main sections, all on one printed circuit board:

- 1) Processor, which controls the operation of the PABX.
- 2) An 8 by 20 Crosspoint Matrix, which makes the appropriate connections between extensions, outside lines and tone lines.
- 3) The line interfaces. These are of two types:
 - a) Outside line interfaces.
 - b) Extension interfaces.

Reference to Drawing No. SS126012, the overall block diagram, may be useful.

1.2.2 PROCESSOR

The processor used is an Intel 8085A-2 (IC1). 32K of ROM (IC's5-8) contains the controlling program, and 4K of static RAM (IC's8,9) is provided as a workspace. This RAM has a battery backup, to retain programmed data in the event of a power failure. The processor communicates with both the Crosspoint Matrix and the Line Interfaces by means of a set of shift registers. A number of circuits are connected directly to the microprocessor buses. These include a Tone Generator, the Printer Interface and the Shift Register Interface. The processor is interrupted 200 times per second (i.e. every 5mS). It samples its inputs and updates its outputs once every 20mS. During this period the

processor samples the status of every line, updates a matrix of connections, makes any changes necessary to the Crosspoint Matrix and carries out any line signalling and tone output required. The processor changes the polarity of the ring voltage every 25mS. Call logging information is also output to a printer by the processor on every call made, if desired.

1.2.3. TONE GENERATOR

This consists of an 8155 (IC2) and an 8253 (IC3). The 8253 contains three independent 16-bit counters. Two of these are used to generate frequencies of 350 Hz and 440 Hz. These frequencies are mixed by IC15 and switched as appropriate by pins PC0 and PC1 on the 8155.

The 8155 contains a 14-bit timer, which is used as a Baud rate generator, and three I/O ports. Two of these, ports A and B, are of 8 bits, while port C is only 6 bits. Port C is used to switch the 350 and 440 Hz tones generated by the 8253, to control the Ring Generator, and to drive the 'Busy' LED and the accessory relay.

1.2.4. PRINTER INTERFACE

An 82251A USART (IC20) is used to output call logging and/or diagnostic information to an optional printer. The baud rate is 9600 Baud, and the interface conforms to the RS 232C standard. Connection to the printer is via a Cannon DB25 female socket.

1.2.5. SHIFT REGISTER INTERFACE

Three sets of shift registers are used to control the Crosspoint Matrix, detect ringing, dial out, etc. The interface consists of an LS138 (IC4), which performs some address decoding. This then selects one of six OR or NOR gates (IC's 16, 17), which drive the 'CLOCK' and 'STROBE' lines of the shift registers, when the processor WR line is active. Part of IC15, a quad AND gate, and IC18, a 3-State Bus Driver, form a transceiver, to write/read data to/from the shift registers, on the processor Data Bus line, ADO. Data is thus written to, or read from, the shift registers serially.

1.2.6. BATTERY BACKUP

A small, 100 mAh battery is provided on board. This is solely for the purpose of retaining programmed data in the event of a mains power failure. Data may be retained, without any application of mains power, for a minimum period of 30 hours (typically much longer). If exhausted,

the battery will be fully recharged in 24 hours and will then remain on trickle charge. The RAMs are completely isolated from the remainder of the circuitry under power fail conditions, to prevent the accidental deletion of data. A TL7705 (IC19) Supply Voltage Supervisor is used, and will reset the processor if the +5v power supply falls below 4.75v at any time.

1.2.7. WATCHDOG CIRCUIT

A 'watchdog' circuit is included. The processor is required to send a signal to this circuit at regular intervals. If it should fail to do so, this implies a catastrophic failure. The watchdog then attempts to reset the processor. If it succeeds, a 'soft' failure occurred, and no harm is done. If the watchdog circuit is unable to reset the processor, it tries again. If it is still unable to reset the processor, the Powerfail relays are operated, bypassing the PABX. A service engineer should then be called.

All the above form part of the processor section, and are connected to its Address/Data Bus.

1.2.8. CROSSPOINT MATRIX

A Space Division Switch is made up of ten '2100' 4x4 crosspoint switches (IC31-IC40) (see data sheet), arranged so as to have eight verticals and twenty horizontals. Twelve of the horizontals are connected to the 3 (2) outside lines and the 9 (10) extension lines. Four horizontals are connected to the tones (Ringing Tone, Engaged Tone, and Number Unobtainable Tone). The remaining four are used for audio input and output, the DTMF tone generator and the Dial Tone Detector (if fitted). The eight verticals are floating, and are available for use as speech paths, for the above tones, or for music on hold/paging.

It is essential for correct operation that any signal applied to the transmission gates forming the Crosspoint Matrix remains at least one volt within the supply to the switches. For this reason, the Crosspoint Matrix is run off a +12v supply, and both horizontals and verticals are biased to a quiescent level of +5v. Zener diodes on all inputs provide protection, limiting voltage swings to between +1.4v and +8.6v. These diodes additionally provide protection against acoustic shock, since they limit the maximum amplitude of any audio signal to 7.2v peak to peak.

Each crosspoint IC contains a matrix of 4x4 switches. Any number of switches may be open or closed at any one time. The switches are

addressed by a four bit number and may be set to the desired state (open or closed) by means of a 'data' signal. A latch is associated with each switch, which retains the state of the switch until 'strobe' is pulsed. Evidentially only one switch may be changed in any one IC at a time.

The technique used in the London 12 PABX to set the Crosspoint Matrix to the desired state is to address each of the switches in turn. Thus, switch 1 in IC's 31-40 is set (open or closed) simultaneously, then switch 2 in each IC, etc. This entire process is repeated every 20 ms. The Crosspoint Matrix is set according to a matrix image held in software. Thus, even if a 'glitch' should cause a switch to be set incorrectly, it will be corrected within 20 ms.

Any two lines (e.g. extension to extension, or extension to outside line) may be allocated a speech path by connecting their respective horizontals to the same vertical. There will then exist a bi-directional path, via two series switches. Each switch has a typical resistance of 75 ohms.

1.2.9. SHIFT REGISTERS

Three sets of shift registers are used for input and output. These are made up of 4021's (input) and 4094's (output), cascaded as appropriate.

A 32-bit shift register (IC's 41-44) is used to control the line interfaces and the DTMF decoders and DTMF generator. The relevant signals are: TE1 - TE8 enable to the output of the tone decoders; EXB21 - EXB30 ring the extensions (i.e. operate the Ring Relays); OLD1 - OLD3 operate the outside line dial relays; 8 bits are used to control the 5087 Tone Dialler (IC30).

a 72-bit shift register (IC's 23-30 and IC 63) is used to input data. This is used to determine if a valid DTMF number has been dialled (TS1 - TS8), to read the number (Q1 - Q4) and as an early tone sense (TM1 - TM8) so that action may be taken to prevent tones escaping onto the PSTN lines. It is also used to detect ringing on an outside line (OLR1 - OLR3), for Hook Sense on the extensions (EXH21 - EXH30), and for the Clear Detect function on the outside lines (OLS1 - OLS3) if enabled. The same shift register is used to read the switches on power up, for configuration data.

Fourteen bits of an output shift register (IC's 45, 46) are used to control the Crosspoint Matrix. Four bits address one of the sixteen switches in

each chip of the Crosspoint Matrix and ten bits provide a bit of data to each chip. The Crosspoint Matrix is strobed simultaneously with this shift register. This shift register operates on a 12v supply, since it drives the Crosspoint Matrix. IC47 provides the appropriate level translation.

The above shift registers are all of the latched type. The outputs remain constant while new data is shifted in serially, controlled by the 'clock' line. When this is complete, the data is transferred in parallel to the outputs by pulsing the 'strobe' line.

Input is the reverse process: data is latched in parallel by the P/S line, and then shifted into the processor by 'clock'.

1.2.10. TONE DECODERS

Eight MT8870 DTMF (IC51-58) tone decoders are provided, one connected to each of the verticals. When one of the tone decoders detects what may be DTMF tone, it asserts its 'Tone Mask' output (one of TM1 - TM8). The processor then briefly disconnects the outside line, if appropriate, to check that the tone originates from an extension, and to prevent tones escaping onto the PSTN lines. Although most signals are sampled every 20 ms, the Tone Mask inputs are checked every 15 ms by the processor. This ensures that less than 10 ms of tone may reach the PSTN lines.

If the tone decoder has detected a valid tone pair it asserts its 'Tone Sense' output (one of TS1 - TS8). This is shifted in and detected by the processor, which then asserts the appropriate 'Tone Enable' line (one of TE1 - TE8). This gates the decoded 4 - bit number onto the Q bus, which is then shifted into the processor, which may then take the appropriate action.

1.2.11. LINE INTERFACES

The Line Interfaces perform 2 to 1 wire conversion. The bi-directional speech path is separated off via an isolating transformer. A pair of back to back zener diodes limit the "voice" signals to between +11.4v and +8.6v. A capacitor (C8) provides d.c. isolation and a resistor (R11) tied to the +5v supply biases the horizontal to this level.

Each Line Interface also has an input and an output, connected to the processor via the shift registers. These are used for ringing, ring detection, dialling and hook sense. The Outside Line Interfaces have an additional output, which is used for clear detect.

1.3 OUTSIDE LINE INTERFACES

There may be 2 or 3 of these, depending on configuration. An Outside Line Interface (OLI) is a passive circuit and effectively simulates a telephone to an exchange on the PSTN. It contains two relays, the Dial Relay and the Mask Relay, both of which are normally open. The OLI also includes ring and clear detect circuitry, and three LEDs for testing/diagnostic purposes.

The three connections to the shift registers are Outside Line Dial (OLD1 - OLD3, o/p from processor), Outside Line Ring (OLR1 - OLR3, i/p to processor) and clear Detect (OLS1 - OLS3, i/p to processor).

The three LED's are used to indicate the following:-

LED1 RING SENSE This will light up in time with the ring signal cadence received on an outside line.

LED2 RELAY CLOSED This indicates that the Dial Relay, RD, is closed, thus looping the line. It will also flash in time with the loop disconnect dialling pulses.

LED3 CLEAR SENSE This will flash on whenever a PSTN disconnect clear signal is received.

These LED's are provided for testing and diagnostic purposes. Verification of the correct timing of the Ring Sense and Clear Sense signals is carried out by the processor.

A powerfail relay is associated with each outside line. These will connect Outside Lines 1, 2 and 3 to extensions 21, 22 and 23, respectively in the event of a mains power failure. The powerfail relays are also operated should the processor fail.

1.3.1 RING DETECTION

When an incoming call is made to the PABX on an outside line, the remote exchange applies a ring voltage of approximately 60v rms at 20 Hz. A diode bridge (D15 - D18) is connected across the A and B wires via a capacitor and a resistor (C12 and R1, respectively) - the "bell capacitor", when the line is unlooped. Level detection is carried out by two zener diodes, D1 and D2. C11 and RR19 prevent the Ring Detector from

responding to short spikes or transients on the PSTN lines. Provided a ring voltage of sufficient amplitude and duration is present, an opto-isolator, OPT1 will conduct, pulling the ring sense line, OLR1, low. This may then be detected by the processor, which checks for the proper cadence. The opto-isolator protects the low voltage (PELV) circuitry from the higher voltages on the PSTN (and visa versa, in the event of a fault).

The processor will close the Dial Relay once a reception 'phone has been answered. This allows about 30 mA to flow through the Outside Line loop, indicating the 'off-hook' condition to the distant exchange, and completing the speech path. This disconnects the Ring Detector. The Dial Relay remains closed until the end of the call, when the Ring Detector is reconnected to the outside line.

1.3.2 DIALLING

When a user makes an outgoing call, the Dial Relay is closed, signifying an "off-hook" condition. The user should then hear a Dial Tone from the distant exchange. Dialling is usually carried out using the Loop - Disconnect method. The Dial Relay is repeatedly opened and closed, with a make/break ration of 30 ms / 70 ms and an interdigit pause of 800 ms. A second relay, the Mask Relay, is operated during a dialling to prevent large back emf's from appearing across the Line Signalling Transformer and to prevent the user from hearing irritating clicks in the receiver.

Alternately, DTMF dialling may be used, if enabled. This is considerably quicker, but it is not currently available on all PSTN exchanges. A single DTMF generator, a Mostek 5087 (IC59) may be fitted. This may be connected to any of the verticals, under processor control, and used for dialling out on an outside line. Tone pairs are transmitted for a period of 80 mS, with an inter-digit pause of 100 mS. The frequencies used correspond with the relevant CCITT recommendation. It is possible to program the system so that DTMF dialling out is only used on selected outside lines.

This Tone Generator is used by the processor to test the Crosspoint Matrix at intervals, when the PABX is idle.

1.3.3 CLEAR DETECTION

The London 12 is normally configured as a loop calling, disconnect clearing PABX. An exchange disconnect clear detection circuit is included

in each OLI. This consists of a diode bridge in the A wire (D21 - D24), which drives an opto-isolator, OPT2. The output of OPT2 is buffered by IC60 and used to drive an LED and to provide a 'Clear Detect' signal to the processor. Disconnection of the lines by the PSTN exchange at the end of the call will put a logical '0' on the Clear Detect line, which is taken by the processor to signify the end of the call, and the line is then unlooped. The exchange disconnect clear function only applies to incoming calls, and the status of the flipflop is ignored on outgoing calls, which are terminated by the calling extension.

Since ordinary 'domestic' subscriber lines are not usually provided with a disconnect clear signal by the PSTN exchange, the PABX may be configured to clear any outside call under control of the extension. A time out of 10 seconds is then applied before the outside line is regarded as available for use for outgoing calls. Incoming calls may be recognised during this period.

1.4 EXTENSION INTERFACES

There may be 9 or 10 extensions, depending on the configuration. An Extension Interface is an active circuit, and supplies 48v to the extension telephones, via a resistance of 700 Ohms. The Extension Interface is a balanced circuit, in order to minimise crosstalk in long cable runs. The speech path is connected to the Crosspoint Matrix as before. There are two connections to the shift registers. Extension Hook Sense (EXH21-EXH30, i/p) and Extension Bell (EXB21-EXB30, o/p). Reference should be made to Drawing No. SS12E007, the Extension Line Interface Circuit, during the following discussion.

1.4.1 DIALLING

When an extension is 'on-hook', the loop is broken, and no current flows. If a user picks up an extension, the loop is completed and up to 57 mA flows (typically 30 mA). The voltage on the return tapping of the line signalling transformer therefore rises to about 15v, causing diode D5 forward conduct. Zener diode, D14, eliminates the effect of any spurious voltages which may be present due to capacitance effects. The voltage on the Hook Sense line (EXH21 EXH30) then rises, limited to a maximum of 4.7v by D6. The processor senses this and connects the appropriate horizontal speech path to a Dial Tone. The Hook Sense line also drives an LED via TR1. If DTMF dialling is enabled the processor waits for a tone decoder to detect and output a valid code and then takes the appropriate action. Loop - disconnect dialling may also be used, even if DTMF dialling

is enabled. Loop - disconnect dialling is detected by the processor if the EXH line rises and falls with the appropriate timing.

1.4.2 RINGING

When the PABX rings an extension, in order to put through a call, one of the extension Bell lines (EXB21 - EXB30) is asserted. This closes the Ring Relay, which disconnects the extension from the Extension Interface and connects it to the RING rail (R7 and C16). The switching of the relay is synchronised with the RING voltage so that the potential difference across the relay contacts is a minimum at the instant of switching.

The extension telephone will then ring with a cadence depending on whether an internal or incoming call is in progress. When the extension is answered, the EXH line will rise during the +ve half cycle of the ring, which is sensed by the processor. The Ring Relay is then released, reconnecting the extension to the Extension Interface. Speech may then proceed.

1.5 RING GENERATOR

As previously noted, the 8155 (IC2) outputs two signals, RA and RB on pins 39 and 2, respectively. These signals are used to control the Ring Generator, switching +60v and -60v alternately onto the Ring rail, effectively producing a pseudo-sine wave at a frequency of 20 Hz. IC49 is used. This rail is connected to all the Extension Interfaces and is used to ring the extension telephones. A small series resistor, R2, is included in each Extension Interface. This is designed to act as a fuse and will blow if the ring voltage is not removed when the extension is answered.

1.6 POWER SUPPLIES

Seven power rails are provided on board. A single mains transformer, type TS408, provides the appropriate a.c. voltages which are then rectified and regulated by five linear regulators. The +/- 60v supply to the Ring Generator is not regulated.

The power supplies are as follows:-

VOLTAGE RAIL	PURPOSE	MAXIMUM RATING	QUIESCENT CURRENT
+5v	Main logic supply	1200 mA	800 mA
+5R	Relay supply	500 mA	100 mA
+12v	Crosspoint Matrix, RS232C, Op-amps	100 mA	50 mA
-12v	RS232 C, op-amps	100 mA	20 mA
+48v	Extension feed voltage	600 mA	0
+60v	Ring voltage	150 mA	10 mA
-60v	Ring voltage	150 mA	10 mA

An additional supply, + 5B , is derived from the main +5v rail. This is used to charge the on-board battery and to drive IC's 9, 10 and 19. Under powerfail conditions this battery supplies power to the above IC's. The maximum rated current is 125 mA, the quiescent current is 50 mA and the powerfail (standby) current is 3 mA.

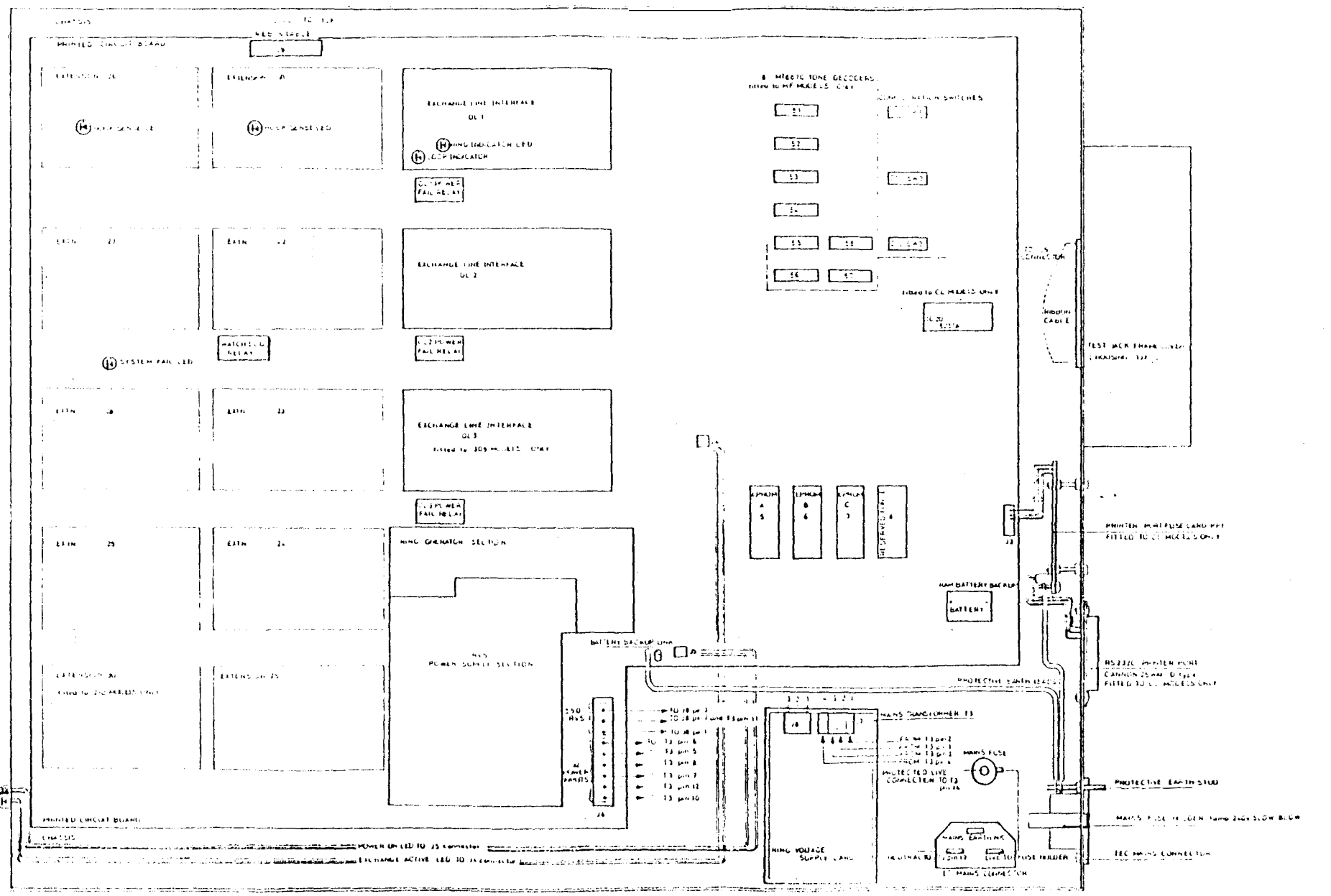

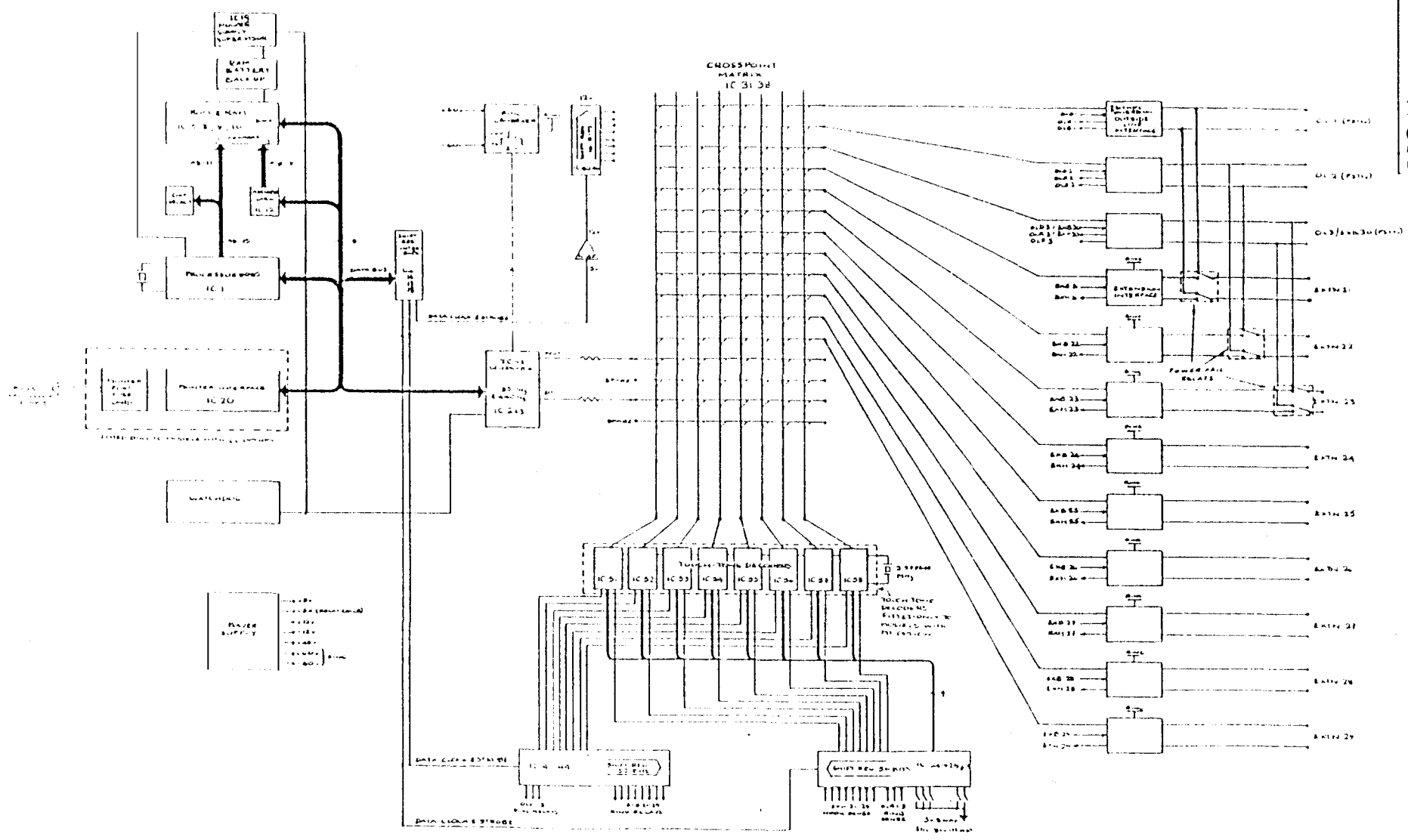

DRG. No.

ISSUE 1.0	DATE	BY
1984-01-24	1984	J. M.
DESCRIPTION	CHANGED DATE	
REVISIONS		
5512 SYSTEM BLOCK DIAGRAM		

DRAWN	TRACED	CHECKED	APPROVED	DATE	SCALE
J.B.		D.W.		11/1/84	

DRAWING No. 5512-SYSTEM BLOCK

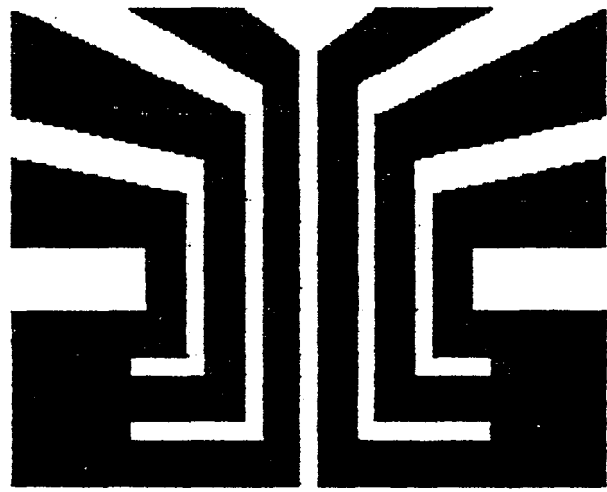

small systems engineering

SECTION 2 INSTALLATION GUIDE

CONTENTS

	Page
SECTION 2 : INSTALLATION GUIDE	
2.1 Requirements	2.2
2.2 Installation Parts	2.2
2.3 Tools And Test Equipment	2.3
2.4 Site Requirements	2.3
2.5 Installation Instructions	2.3
2.5.1 General	2.3
2.5.2 Installing The London 12	2.4
2.5.3 Extension Wiring	2.4
2.5.4 Attachments	2.5
2.5.5 Wall Mounting	2.6
2.4.6 Visual Inspection & Pre Connection Power Up Check	2.6
2.4.7 London 12 Internal Switch Settings	2.6
2.4.8 Earth Connections And Safety Dependant Features	2.8
2.4.9 Call Logging Printer Port	2.9
2.4.10 System Tests	2.9
2.4.11 System Programming	2.11
2.4.12 System Configuration Record	2.12
2.5 Site Documentation And Labels	2.12
2.5.1 Documents	2.13
2.5.2 Labels	2.13

FIGURES

Figure No.

1	TJF/MDF	2.5
2	Location Of DIL Switches On PCB	2.7
3	Switch 1 Settings	2.7
4	Switch 2 Settings	2.8
4a	Switch 3 Settings	2.8
5	System Configuration And Programming Record	2.14
6	Completion Certificate	2.15
7	Wiring Layout	2.16

SECTION 2 INSTALLATION

2.1 REQUIREMENTS

The LONDON12 PABX must be installed in compliance with the Dept Of Industry's "Interim Code Of Practice For Installation Of PBX's" (this will eventually be replaced by a new British Standard - BS6506).

2.2 INSTALLATION PARTS

The following items are required to install the LONDON 12:

ITEM	QTY
LONDON 12 central control unit	1
Mains lead and plug fitted with 2amp fuse	1
Approved (BS 6301) telephones	As required
Extension sockets (Line jack units 2/1A)	As required
Outside line test sockets (Line jack units 2/1A)	One per outside line
Cable (1 pair per extension)	As required
Power protective earth cable min 1.5 sq mm (as per IEE regulations 15th edition)	As required
80 column printer with RS 232 interface (optional)	1

The system is supplied in four configurations depending on size and type of dialling. Information specifying the configuration is contained in the system model number:

SS12-309-XX-CL -- 3+9 version
SS12-309-MF-CL -- 3+9 version with MF dialling
SS12-210-XX-CL -- 2+10 version
SS12-309-MF-CL -- 3+9 version with MF dialling

All versions have a RS 232/V24 call logging interface fitted as standard, and are designed to operate with approved (BS 6301) 10 pps loop-disconnect telephones. MF versions will operate with either loop disconnect telephones (no recall button required) or with MF Timed Break Recall telephones (recall button required).

2.3 TOOLS AND TEST EQUIPMENT

ITEM	QTY
Krone IDC inserter tool	1
Suitable exchange line simulator	1

2.4 SITE REQUIREMENTS

The LONDON 12 is designed to work in a normal office environment. The central control unit should be sited with ease of access in mind and should be away from:

- a) Hazardous areas
- b) Processes producing electricity, fumes, dust, gasses or radiation (e.g. silicon or halon contamination from photocopying or fire protection equipment).
- c) Electrical meters or switchgear.
- d) Fire sprinkler systems.
- e) Water pipes.
- f) Gas meters, pipes or appliances.
- g) Dampness.
- f) Vibration.

The central control unit should be sited at a convenient working height in a well lit room. It should be sited in a room which is normally supervised or a room to which access is restricted.

2.5 INSTALLATION INSTRUCTIONS

These instructions must be carefully read before proceeding with the installation of the LONDON 12.

2.5.1 GENERAL

The central control unit is wall mounted or horizontally desk/table top mounted according to customer requirements within 3 cable metres of a suitable 240V 13A socket outlet. It is recommended that the socket should be surface mounted, of the double switched type and used exclusively for the LONDON 12 and printer. The socket should be labelled : "TELEPHONE EQUIPMENT DO NOT REMOVE". Whenever possible the customer should be asked to provide a "clean" supply direct from the power distribution board.

2.5.2 INSTALLING THE LONDON 12

WARNING: THE CENTRAL CONTROL UNIT CONTAINS CMOS COMPONENTS WHICH ARE PRONE TO DAMAGE FROM STATIC ELECTRICITY. ANTI-STATIC PRECAUTIONS (SEE BS5783) SHOULD BE TAKEN WHEN WORKING ON OR NEAR THE UNIT.

The LONDON 12 installation involves the following sequence of operations: Install and check the extension wiring and extension telephone sockets. Install and test power protective earth wire to a proven building earthing point.

Mount the central control unit according to customer requirements, wall fixing or horizontal desk/table mounting.

Install the outside line test sockets (one per outside line) adjacent to central control unit.

Carry out a visual inspection of the control unit modules, switch settings and safety dependant features.

Carry out a preliminary power-up check prior to connecting the extension wiring.

Connect extension wiring according to the customer's extension numbering plan.

Connect one test socket to each outside line port.

Connect the battery back-up by inserting the MOLEX link on the PCB, power up and perform preliminary tests.

Carry out system programming in accordance with the Programming Configuration Requirements Form.

Complete a LONDON 12 Configuration And Programming Record Form.

(See figure 5)

Complete a Certificate Of Satisfactory Completion (See figure 6).

NOTE: Connection of PSTN lines to the LONDON 12 can only be carried out by British Telecom personnel. A 3 pair cable "tail" (max 15 metres) should be provided by the installer for this purpose.

2.5.3 EXTENSION WIRING

Extensions are wired in a 2 wire star configuration with telephones connected via type LJ 2/1A sockets. Each socket must bear a label carrying the following warning:

WARNING: CONNECT ONLY APPARATUS COMPLYING WITH BS 6301 TO THIS PORT.

Extension wiring run externally to the building must not exceed 220 metres.

Maximum extension loop resistance is 42 ohms. This is equivalent to a 250 metre run of 0.5 sq mm copper cable. Connections are as follows:

Central Control Unit Connections (see fig. 1)	Extension Line Jack Unit Connections
A	2
B	5

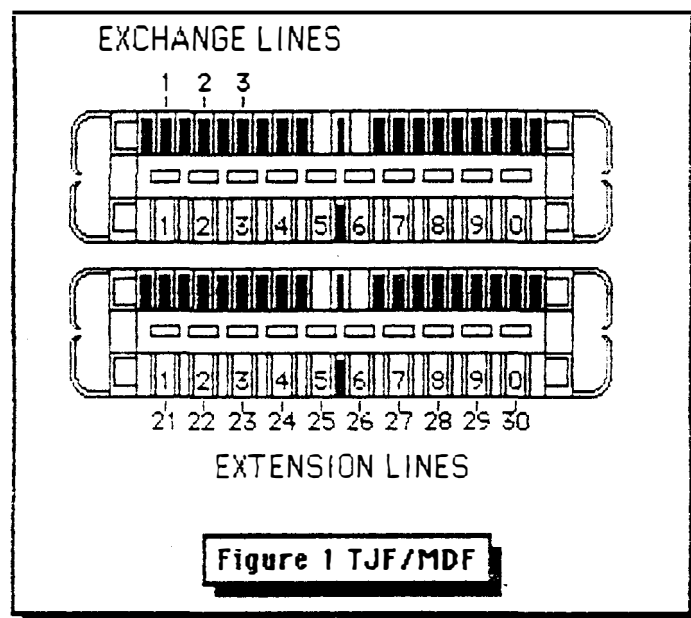

Ensure that extensions 21 and 22 are both equipped with loop disconnect telephones. If MF telephones are fitted, loop-dis telephones should be available for use under power fail conditions .

2.5.4 ATTACHMENTS

Only approved attachments (e.g. extension bells, callmakers, telephone answering machines, modems etc) may be connected to the LONDON 12. These attachments must conform to BS 6301 and this is normally indicated by the prefix 'S' (meaning statutory) to the approval number. The LONDON 12 can handle up to 3 bells/sounders, including the telephone, on each extension port.

2.5.5 WALL MOUNTING

The hole positions for the four fixing screws should be accurately marked on the wall using the template provided. The four roundheaded screws provided should be adjusted such that the unit is a tight push fit when located on to the screws. Mount the unit such that the ventilation slots are at the top.

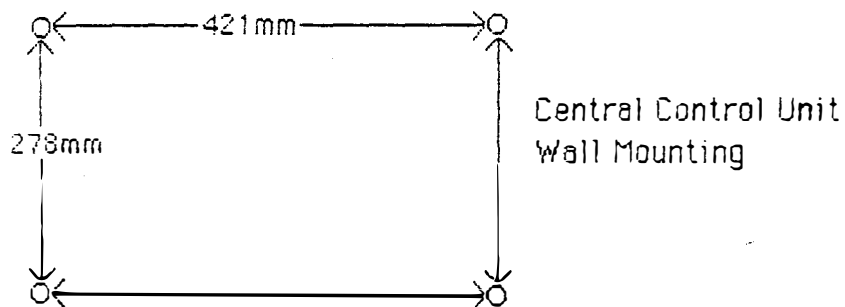

2.5.6 VISUAL INSPECTION AND PRE CONNECTION POWER UP CHECK

Before connecting any extension wiring carry out the following checks:

Check that all inter-pcb cabling is secure. Ensure that the correct EPROM's are securely installed and that the firmware issue labels show the correct issue number as detailed in the PXML.

Check that the DIL switch settings are set for the required system configuration. See the section below on LONDON 12 switch settings.

2.5.7 LONDON 12 INTERNAL SWITCH SETTINGS

The internal DIL switches are normally factory set for one of the standard LONDON 12 configurations. Switch settings are shown overleaf:

The switches are arranged in 3 banks:

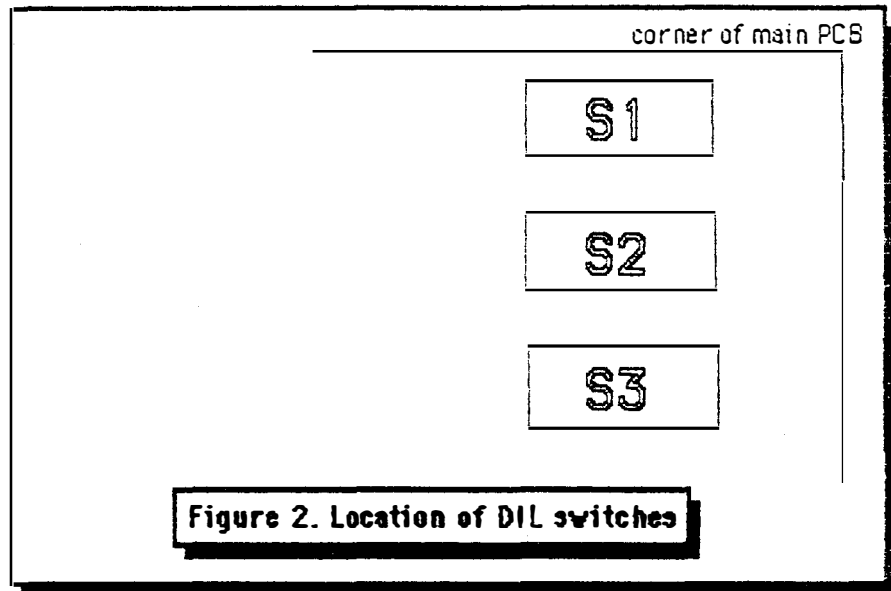

S1 determines what kind of dialling is used for outgoing calls on each outside line.

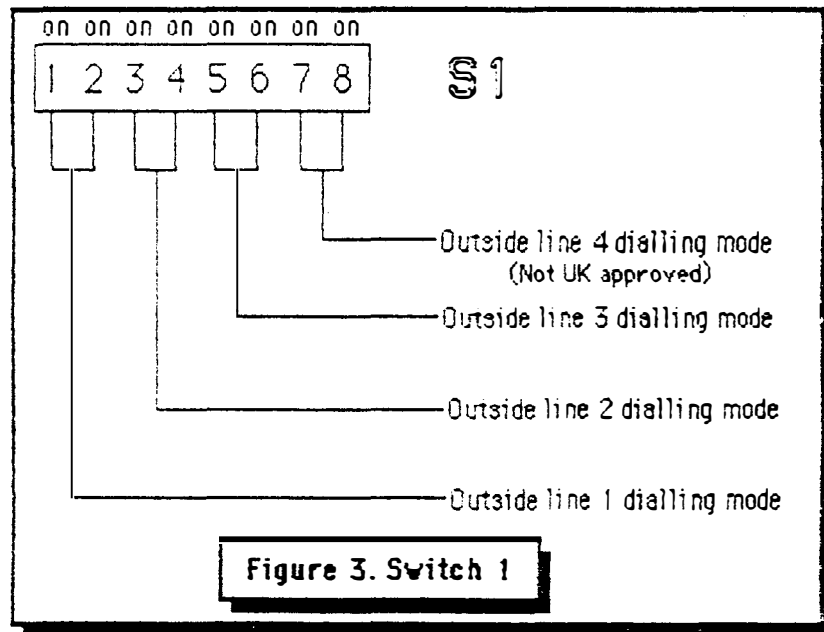

Outside line dialling modes:

- OFF OFF = Line not used for outgoing calls
- ON OFF = Use MF dialling on this line (N/A UK model)
- OFF ON = Use 10 pps loop disconnect dialling on this line

S2 defines whether or not MF receivers are fitted:

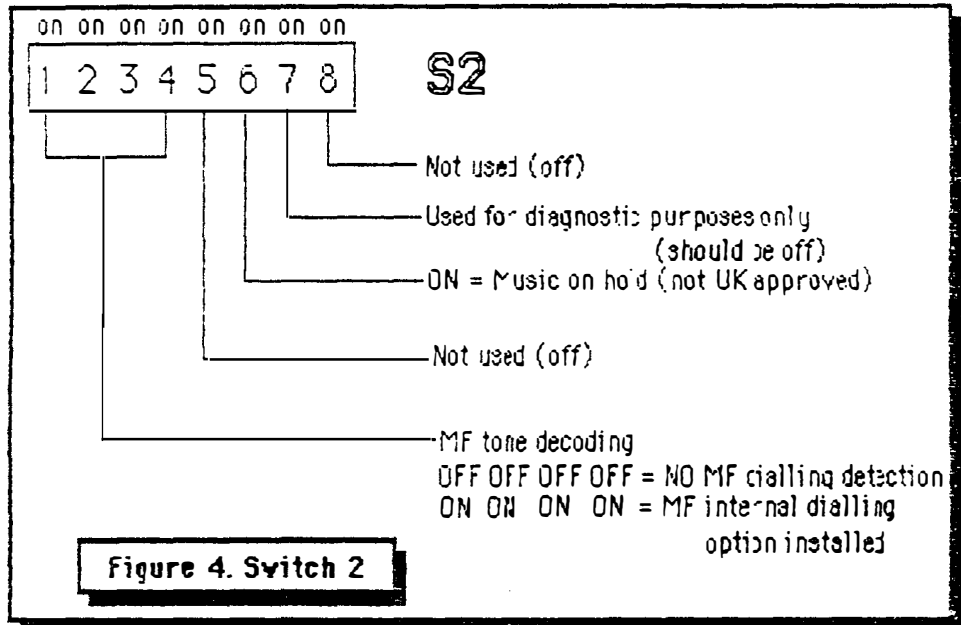

S3 determines the system size:

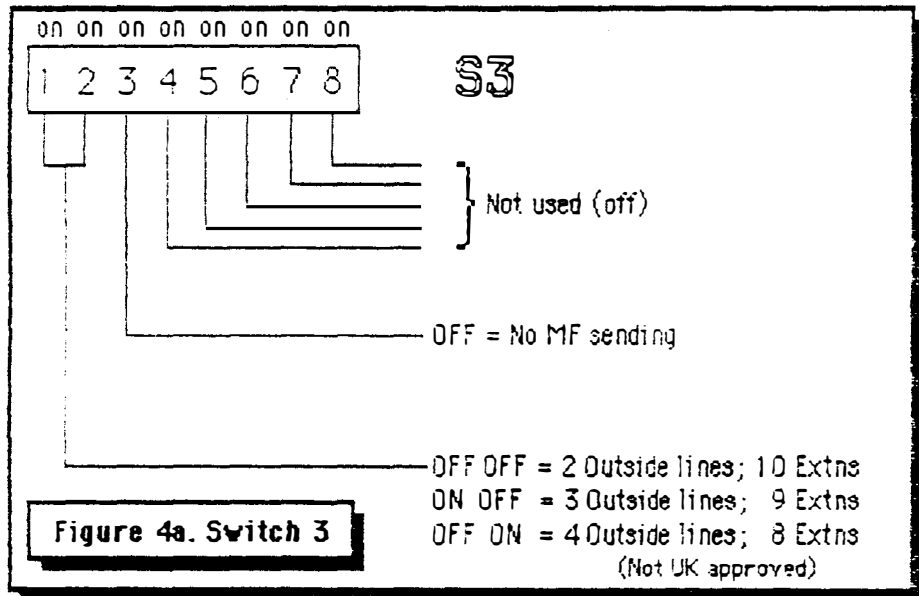

2.5.8 EARTH CONNECTIONS AND SAFETY DEPENDANT FEATURES

Ensure that a protective earth strap is connected between the unit's protective earthing point and a proven building earth point. Check continuity of the earth connection.

Ensure that the mains lead is terminated in a BS 1363 13 amp mains plug fitted with a 2 amp fuse.

Ensure that the correct value mains input fuse is installed in accordance with the label on the central control unit: 1 A SLO BLO FUSE. The fuse holder is located above the mains connector on the side of the central control unit.

Ensure that the correct type of fuses are fitted in the printer port fuse disconnection barrier as per the labelling on the printer port fuse PCB.

Check continuity between protective earth point and the internal earthing point on the printer port fuse PCB.

2.5.9 CALL LOGGING PRINTER PORT

Connect a suitable printer or terminal to the 25 way D-type CL port connector. The port conforms to the RS 232/V24 standard and uses the following signal lines:

PIN	SIGNAL
3	Transmitted data (to printer)
7	Signal ground
20	Data terminal ready (DTR)

Data is transmitted with even parity and one stop bit at a Baud rate determined by one of the following programming codes:

BAUD RATE	PROGRAMMING CODE
9600	19680
4800	19681
2400	19682
1200	19683

Power up the unit and check that the SS12 sign on message and system configuration details are printed.

2.5.10 SYSTEM TESTS

Connect the extension wiring in accordance with the customer's extension numbering plan. See figure 1.

Connect one outside line test socket (LJ 2/1A) to each outside line port as follows:

Central Control Unit
Outside Line Connections

Line Jack Unit
Connections

A
B

2
5

Each line jack should be labelled LINE 1, LINE 2 etc. and should also carry a warning label.

Replace the plug in module containing the outside line surge arresters.

Note: If any external extension wiring has been provided, each pair should also be protected by surge arresters .

Connect the RAM battery backup by inserting the battery link so that it bridges the two MOLEX pins. The position of the link is shown on the System Component Identification Drawing SS12G011.

Carry out the following tests:

On each extension check:

- Internal dial tone
- Ringing
- Dialling (dial another extension)

For each outside line circuit installed check line siezing and dialling:

Select each line by dialling 81, 82, etc and dial 0. Check that the line siezed LED comes on and that the dialling relay is activated.

Check the battery back up:

Note: If the RAM battery is completely exhausted it will require charging for 24 hours prior to carrying out this test.

Set call diversion from extension 21 to extension 22 by dialling from extension 21:

60422 Check that calls are diverted.

Switch off the mains power and switch on again after 30 seconds.

Check that calls are still diverted from extension 21 to extension 22.

Cancel call diversion by dialling:

605 from extension 21

Check that the diversion has been cancelled.

Check incoming ringing using a suitable exchange line simulator.

Check that extensions 21 and 22 ring for incoming calls on each outside line.

Call Logging Port:

Turn on call logging by dialling:

19651 from extension 21 (Masterphone)

Check the call logging print out on the customer's printer unit

Switch off the mains power and check that outside lines 1-3 are switched through to extensions 21-23.

2.5.11 SYSTEM PROGRAMMING

Set the correct time and date. Refer to LONDON 12 Owner's Programming Guide (Section 3).

If the customer has requested that the master programming phone should be an extension number other than 21, reprogram the master extension by dialling from extension 21:

1966 + No. of required master extension.

Carry out any system programming required in order to configure the system to the customer's specification.

Certain time-out values on the LONDON 12 are configureable. Since these values cannot be displayed or printed, and because operational problems can occur if they are changed without careful consideration, it is strongly recommended that the programming codes associated with these time-outs are not made known to the Customer.

The time-outs are as follows:

a) **CAMP-ON BUSY RETURN** - The time after which calls camped on to a busy extension by a Reception Phone will be returned to the Reception Phone(s) if the required extension does not become free.

b) **UNANSWERED CALL RETURN** - The time after which a call extended from a Reception Phone will be returned to the Reception Phone(s) if the required extension does not answer.

c) **PARKED CALL RETURN** - If an extension parks a call then replaces the receiver the call will return after this period of time.

d) **ALARM CALL TIME-OUT** - The length of time for which an unanswered alarm call will continue to ring an extension.

e) **AUTOMATIC RINGBACK TIMEOUT** - The length of time for which an unanswered ringback will continue, indicating that a requested extension or outside line has become free.

Time-outs can be changed by using the following codes from a Masterphone:

<u>TIMEOUT</u>	<u>PROGRAMMING CODE</u> (Where xxx is a time in seconds between 001 & 250)	<u>DEFAULT</u> <u>VALUE</u>
Camp-on busy return	1911xxx	045
Unanswered call return	1912xxx	030
Parked call return	1913xxx	010
Alarm call time-out	1914xxx	240
Automatic ringback timeout	1915xxx	015

Check programmed configuration.

Note: If the system is being checked for a possible outside line fault a programming code may be used to "busy out" selected lines:

1931 + line Causes the outside line to be ignored for outgoing calls.

193² + line Causes outside line to be re-instated.

2.5.12 SYSTEM CONFIGURATION RECORD

Complete a LONDON 12 Configuration And Programming Record form and leave it with the system.

A sample record showing the default programme is shown in figure 5.

2.6 SITE DOCUMENTATION AND LABELS

The following documentation should be available on site prior to connection to the PSTN by B.T:

2.6.1 DOCUMENTS

- 1) Private Exchange Master List (PXML 87).
- 2) Copy of a maintenance contract issued by an approved maintainer and signed by the customer.
- 3) System Configuration And Programming Record Form (see figure 5).
- 4) Certificate of satisfactory completion (see figure 6).
- 5) Installation layout drawing showing the positions of all extension sockets and any distribution points (See Figure 7).
- 6) User guide - one per extension.

2.6.2 LABELS

- 1) '999' Labels fitted to each telephone.
- 2) Label on each socket: WARNING CONNECT ONLY APPARATUS COMPLYING WITH BS 6301 TO THIS PORT.
- 3) Label on the cover of the central control unit:
WARNING : THIS COVER SHOULD ONLY BE REMOVED BY AN AUTHORISED MAINTAINER.

small systems engineering

**London 12 System Configuration And
Programming Record**

Customer _____ Installer _____
 Site Address _____ Installation Date _____
 _____ Model No. SS12- - -
 _____ Serial No. _____

Exchange lines:

Line 1 Tel No. _____ Power fail extn 21
 Line 2 Tel No. _____ Power fail extn 22
 Line 3 Tel No. _____ Power fail extn 23

Extension Programming Configuration:

User/Location	Ext	Ring	Dial	Answer	Bar	Hunt	Divert	Attrib
	21	7/7	7	7	0/0	0	None	M
	22	7/7	7	7	0/0	0	None	
	23	0/0	7	7	0/0	0	None	
	24	0/0	7	7	0/0	0	None	
	25	0/0	7	7	0/0	0	None	
	26	0/0	7	7	0/0	0	None	
	27	0/0	7	7	0/0	0	None	
	28	0/0	7	7	0/0	0	None	
	29	0/0	7	7	0/0	0	None	
	30	0/0	7	7	0/0	0	None	

Figure 5.

Figure 6. Completion Certificate

CERTIFICATE OF SATISFACTORY COMPLETION

This is to certify that a PABX type **SMALL SYSTEMS LONDON 12**,
model number SS12-.....-.....-....., serial number.....

was installed at

.....

.....

on..... (date) in accordance with the requirements for
installation in the Secretary of State's approval number 84/0121 and in
accordance with the recommendations of BS 6506 and/or The Interim
Code Of Practice For Installation Of PBX's.

The following documents have been left on site:

PXML 87 Issue.....

Copy of maintenance contract issued by an approved maintainer and
signed by the customer.

Signed..... Date.....

On behalf of.....

small systems engineering limited

Site Name _____
Date _____

Figure 7. Wiring layout

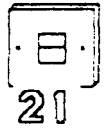
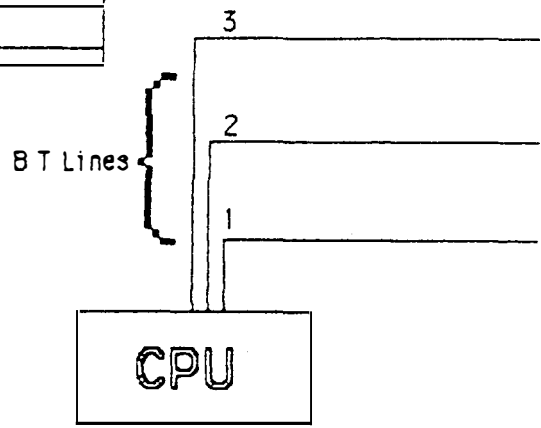

KEY :-

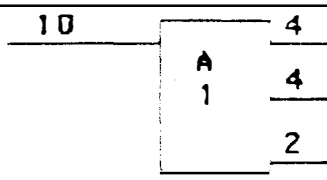
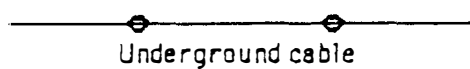
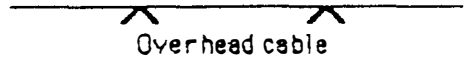

Distribution Point showing number of pairs

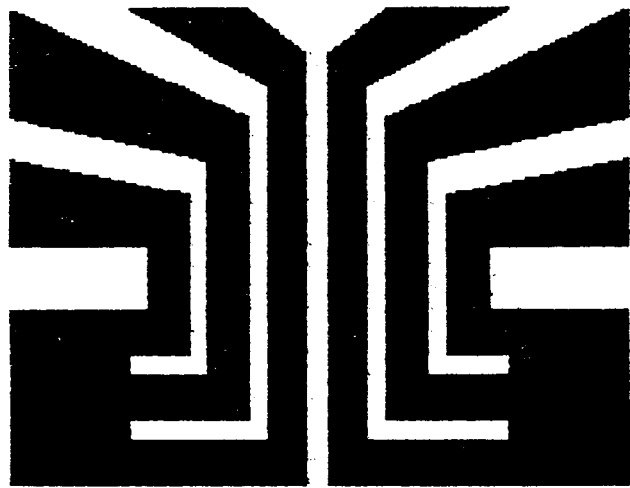

small systems engineering

SECTION 3 PROGRAMMING GUIDE

CONTENTS

	Page
SECTION 3 : OWNER'S PROGRAMMING GUIDE	
3.1 Introduction	3.2
3.1.1 London 12 configurations and optional MF facility	3.2
3.1.2 Operating the London 12 in compliance with BS6450	3.2
3.1.3 Power fail operation	3.2
3.2 Introduction to programming and configuring the London 12	3.3
3.2.1 London 12 configuration and programming record	3.3
3.2.2 Programming codes	3.3
3.2.3 Examining the PABX configuration	3.4
3.2.4 Programming the switchover of Day/Night modes	3.5
3.3 Setting the time and date	3.6
3.4 Call logging	3.7
3.5 Programming the central dialling memories	3.8
3.6 Programming individual extensions	3.9
3.6.1 Setting the range of extensions to be programmed	3.9
3.6.2 Call barring	3.10
3.6.2 Ringing	3.10
3.6.3 Outgoing line restrictions	3.12
3.6.4 Incoming call answering using the 61 code	3.12
3.6.5 Remote call answering protection	3.13
3.6.6 Call interruption protection	3.13
3.7 Setting Reception Phones	3.15
3.8 Summary of programming codes	3.16
System Configuration And Programming Record	3.18

3.1. INTRODUCTION

3.1.1. LONDON 12 CONFIGURATIONS AND OPTIONAL MF FACILITY

The London 12 may be supplied in one of two line configurations:

2 Exchange lines + 10 Extensions (Model No SS12-210-XX-CL)

3 Exchange lines + 12 Extensions (Model No SS12-309-XX-CL)

CL (Call Logging Printer Port), supplied with all systems, provides a printer port for the connection of a V24 9600 baud printer.

The London 12 may be installed with the following optional facility:

MF (Touch Tone) operation for extension telephones. (Denoted by letters MF in model number). With the MF option fitted, any extension socket is compatible with either MF telephones or Loop Disconnect (dial pulse) telephones. The MF telephone must have timed break recall.

3.1.2. OPERATING THE LONDON 12 IN COMPLIANCE WITH BS6450

The London 12 has been approved only for operation with extension telephones approved to BS6317.

WARNING: Interconnection directly, or by way of other apparatus, of ports marked "WARNING: connect only apparatus complying with BS6301 to this port" with ports not so marked may produce hazardous conditions on the BT lines and advice should be obtained from a competent engineer before such connection is made.

3.1.3. POWER FAIL OPERATION

In the event of a mains power failure the London 12 will automatically connect exchange lines 1, 2 and 3 to extensions 21, 22 and 23 (or extns. 21 and 22 in the case of a 2 line system).

Note: In Power Fail mode the extension telephones connected to the power fail fallback extensions must be loop disconnect, pulse dialling telephones. The London 12 Installation and Configuration Record will contain information concerning the numbers of the BT lines which will be connected to each power fail extension.

All stored numbers and system programming information (apart from time and date) will be retained for at least 10 hours by internal battery backup.

3.2. INTRODUCTION TO PROGRAMMING AND CONFIGURING THE LONDON 12 PABX

The London 12 has been designed to provide considerable flexibility in the system configuration and modes of operation. In addition to the user features and programming facilities described in the user guide, the London 12 has a number of programming facilities which are normally not available to all users.

This manual describes programming facilities which may be useful to the system owner.

3.2.1. LONDON 12 CONFIGURATION AND PROGRAMMING RECORD

The system installer will have completed a "Configuration and Programming Record" for your London 12 PABX. It is important that this document is kept in a safe place and updated whenever the system configuration is altered in any way. It provides a useful overview of the SS12 programming facilities.

Certain items defining the system configuration can only be set or modified by the installer or approved maintainer of your system. These are:

- * Number of outside lines connected to the London 12: 2 or 3
- * The phone numbers of each line: as defined in configuration record.
- * Number of extensions: 9 or 10
- * The number of the master programming phone (from which the codes in this guide are operative): normally extn. 21

If you have special requirements in relation to any of the above facilities then you should arrange for your installer to configure the system accordingly.

3.2.2. PROGRAMMING CODES

The special dialling codes listed in this manual can only be dialled from a master extension. Master extensions have all the properties of normal extensions with some additional capabilities which it might be undesirable to make generally available.

AFTER DIALLING ANY OF THE CODES LISTED IN THIS MANUAL YOU SHOULD HEAR AN INTERNAL DIAL TONE. A "NUMBER UNOBTAINABLE" TONE (CONTINUOUS HIGH PITCH) INDICATES THAT THE CODE HAS BEEN IMPROPERLY DIALLED OR IS NOT BEING DIALLED FROM THE MASTER PHONE.

3.2.3. EXAMINING THE PABX CONFIGURATION

If you have a printer attached to the call logging port of your PABX it is possible at any time to examine the current programming configuration. The special dialling code:

1951

causes current programming information to be listed on the printer in the following format:

Number of extensions	--9/10	Set by installer
Number of outside lines	-- 3/2	Set by installer
Day/night mode	--	Whether currently in night mode

Extension Programming Configuration:

(Entries in table show standard shipping configuration)

Ext.	Ring	Dial	Answer	Bar	Hunt	Divert	Attrib
21	7/7	7	7	0/0	0		M
22	7/7	7	7	0/0	0		
23	0/0	7	7	0/0	0		
24	0/0	7	7	0/0	0		
25	0/0	7	7	0/0	0		
26	0/0	7	7	0/0	0		
27	0/0	7	7	0/0	0		
28	0/0	7	7	0/0	0		
29	0/0	7	7	0/0	0		
30*	0/0	7	7	0/0	0		

Day mode starts at hh:mm:ss A.M.; night mode starts at hh:mm:ss P.M.

* Extn 30 installed only for 2 + 10 configuration

Ring: Line Group for day/night mode ringing

Dial: Line group for outgoing calls

Answer: Line group answered by "61" incoming call remote answer

Bar: Call barring level for day/night mode:

0 = no calls barred

1 = international calls barred

2 = long distance calls barred

3 = emergency calls only (999)

Hunt: Hunt group (1 to 9) that extension is in; 0 = no hunting
Divert: Extn. No. to which calls for this extn. are diverted
Attribute: M = Master phone
R = Remote answering of this extn barred
I = Call interruption barred for this extn

Line Group Selection:

<u>Group Selection</u>	<u>Lines</u>
0	No Outside Lines
1	Line 1 only
2	Line 2 only
3	Lines 1, 2
4	Line 3 only
5	Lines 1, 3
6	Lines 2, 3
7	All lines

(1 & 2 for 2 + 10 config. 1, 2 & 3 for 3 + 9)

3.2.4. PROGRAMMING THE SWITCHOVER OF DAY/NIGHT MODE

It is possible to programme the London 12 so that it switches between day and night modes at the same times each day.

The dialling code to set the start of the day mode is:

1920hhmm

The dialling code to set the start of night mode is:

1921hhmm

where hhmm is the time in 24-hour format.

To cancel, use 19200000 or 19210000.

3.3. SETTING THE TIME AND DATE

The PABX has a built in clock and day/month calendar for use by the call logging option and the alarm call facility.

The dialling code for setting the time is:

1961 + time

The time is given in 24-hour format, hours then minutes, for example:

19610203 2.03 a.m.

19611639 4.39 p.m.

19610000 12.00 (midnight)

The time will be set and the "seconds" counter zeroed when the last digit has been dialled, and a dial tone will be heard.

The date, for call logging purposes, is set by two different codes, one for the numeric day and month, the other for the day of the week.

1962 + day + month

1963 + day of week

For example:

196209129 December

1962300430 April

196201011 January

19631 Monday

19632 Tuesday

19633 Wednesday

19634 Thursday

19635 Friday

19636 Saturday

19637 Sunday

Once the time and date have been set, they only need to be reset if there is a power failure to the exchange. The date must also be reset on 1 March during a leap year.

When completed, these codes should give you a dial tone. a "NUMBER UNOBTAINABLE" TONE (CONTINUOUS HIGH PITCH) INDICATES THAT THE CODE HAS BEEN MIS-DIALLED OR THE TIME/DATE IS OUTSIDE THE APPROPRIATE RANGE.

3.4. CALL LOGGING

The call logging facility is switched on or off by the following codes:

19650	call logging off
19651	call logging on

All external calls (incoming or outgoing) are logged in the chronological order of their completion. The printout shows the following information, in column form from left to right:

1. Date of call (day of week, day, month)
2. Start time (Hours, minutes, seconds, A.M./P.M.)
3. Outside line number (1 to 3)
4. First 18 digits of outside number dialled
(or "INCOMING" if incoming call)
5. Charge account code (if entered) - three digits
6. Length of call (hours, minutes, seconds)
7. Extension number (21 - 30). For outgoing calls this is the extension that dialled the call; for incoming calls it is the last extension that was speaking.

The system will initially power up with call logging on.

3.5. PROGRAMMING THE CENTRAL DIALLING MEMORIES

In addition to the local memories belonging to each extension the PABX has 40 central dialling memories shared between all the extensions, which may be used for storing numbers likely to be dialled by more than one extension.

Numbers stored in memories 50-69 are subject to the call barring restrictions placed on any extension attempting to dial an outside call from them.

Memories 30-49 are freely accessible from all extensions regardless of any call barring.

The central memories are programmed in the same way as the local (extension) memories, except that the memory number is in the range 30 to 69 and that numbers can only be entered from the master programming extension.

To store a number in shared memory, dial on the MASTER PHONE:

603 + NN + outside number

where NN is the 2-digit number of an unused memory in the range 30 to 69. The outside number may be up to 18 digits long. Wait until the phone has finished pulsing out the number (if pulse dialling is being used) and then put the phone down to store the number. Any number previously stored in that memory will be overwritten.

To dial an outside number from a central memory, pick up the extension and dial:

5

WAIT FOR AN OUTSIDE DIAL TONE and then dial the 2-digit code from the memory (30 to 69).

If a call logging printer is installed, the special dialling code:

1952

can be used to list out the contents of all the central dialling memories on the printer

Note: In the event of a mains power failure all stored numbers will be retained in the system memory. Stored numbers can be deleted by dialling 603 NN and then hanging up, or by reprogramming that location with a new number.

3.6. PROGRAMMING INDIVIDUAL EXTENSIONS

The following functions can be programmed individually for each extension:

- * Outside call barring (various levels) for day and night mode
- * Which outside lines are available for outgoing calls
- * Which outside lines cause this extension to ring for incoming calls (independently programmable for day and night mode)
- * Which outside lines can be remotely answered (using the "61" code)
- * Call privacy - Call interruption barring, remote call answering barring, remote call diversion barring
- * Hunting group membership

3.6.1. SETTING THE RANGE OF EXTENSIONS TO BE PROGRAMMED

Before dialling any of the programming codes for setting the facilities available to extensions, the range of extensions you wish to program has to be set by dialling:

18 + FIRST EXTN + LAST EXTN

For example:

182529 - extensions 25 to 29
182226 - extensions 22 to 26
182424 - extension 24 only

Subsequent extension programming codes (listed below) WILL THEN APPLY TO THIS RANGE OF EXTENSIONS ONLY, until a new range is set. The properties of any extensions outside the current range will not be affected.

3.6.2. CALL BARRING

The selected range of extensions can be programmed for one of the four categories of outside call service for day/night mode:

1974X = day mode barring; 1977X = night mode barring

X	day	night	
0:	19740	19770	- allow all calls
1:	19741	19771	- allow no international calls (numbers beginning with 010, 000 or international operators)
2:	19742	19772	- allow no long distance calls (numbers beginning with 0 or operator services [100 to 109])
3:	19743	19773	- allow emergency (999) calls only

Example of setting call barring:

To allow STD calls on extensions 25 and 26 in day mode and local calls only in night mode -

Set range of extensions by dialling:

182526

Set the barring by dialling -

19741

19772

The London 12 is normally installed with all extensions permitted to make any type of call (level 0).

6.3. RINGING

Ring mode, outgoing line access and remote incoming call answering may be programmed for each extension. Each programming command refers to an outside line "group selection", GS. For example:

1972 + GS - control day mode ringing

1973 + GS - control night mode ringing

These two dialling codes set the ringing mode FOR ALL EXTENSIONS IN THE EXTENSION RANGE SELECTED, for day and night mode operation.

GS is a single digit value in the range of 0 to 7 selected from the following table, according to the required outside line group selection:

GS	Outside Line Group
0	No outside lines
1	Line 1 only
2	Line 2 only
3	Lines 1, 2
4	Line 3 only
5	Lines 1, 3
6	Lines 2, 3
7	All lines - 1, 2 for a 2 + 10 system, 1, 2 & 3 for a 3 + 9 system

Some examples of ringing control:

- 19727 - daytime ringing for all lines
- 19735 - nighttime ringing for lines 1 and 3
- 19720 - no ringing at all during day time

As a further example of ringing control, set extension 29 to be an additional ringing phone in night mode (for all lines):

Set extension programming range:

182929

Set night mode ringing for all lines:

19737

The London 12 is normally installed with extensions 21 and 22 as reception phones which will ring for all lines during both day and night operation, while the other extensions do not ring in either mode.

3.6.4. OUTGOING LINE RESTRICTIONS

FOR ALL EXTENSIONS IN THE CURRENT PROGRAMMING RANGE, the following dialling code:

1975 + GS

programs which outside lines can be used to make outgoing calls from the selected extension(s). Whenever a "9", "5" or "8n" is dialled to get an outside line, only lines belonging to the group specified by the GS code can be used to make the outgoing call. If no lines are available, an engaged tone will result. The possible values of GS are listed in the table above.

For example:

- 19757 - can dial out on any line
- 19753 - can dial out on lines 1 and 2 only
- 19754 - can dial out on line 3 only

The London 12 is normally installed with all extensions allowed access to all outside lines.

3.6.5. INCOMING CALL ANSWERING USING THE 61 CODE

FOR ALL EXTENSIONS IN THE CURRENT PROGRAMMING RANGE, these codes determine which outside line groups can be answered from a non-ringing extension using the "61" code. "GS" is defined as above in the section on ringing.

For example:

- 19767 - can answer calls on any line
- 19764 - can answer calls on outside line 3 only
- 19760 - cannot answer calls on any line

The system is normally installed with all extensions able to answer calls on any line using the "61" code.

(See note under point 3.7, page 3.15)

3.6.6. REMOTE CALL ANSWERING PROTECTION

These codes set or clear the "remote call answering protection" attribute FOR ALL EXTENSIONS IN THE CURRENT PROGRAMMING RANGE.

- 19430 - Allow remote call answering/diversion
- 19431 - Prohibit remote call answering/diversion

Setting this attribute prevents calls destined for this extension from being intercepted using any of the remote answering or diversion codes:

- 65xx - remote answer
- 694xx - remote divert
- 695xx - remote undivert

The system is normally installed with remote answering and diversion permitted for all extensions.

3.6.7. CALL INTERRUPTION PROTECTION

These codes set or clear the "interruption protection" attribute FOR ALL EXTENSIONS IN THE CURRENT PROGRAMMING RANGE.

- 19440 - Allow call interruption for this extension
- 19441 - Prohibit call interruption for this extension

Setting this attribute prevents calls on this extension from intrusion by the "66" code being dialled from a reception phone.

The system is normally installed with call interruption permitted for all extensions.

6.8. HUNTING GROUPS

It is possible to have up to nine hunting groups on the London 12. These are numbered 1 to 9 and are accessed by dialling 31 to 39.

To put all the extensions in a programming range into a hunting group, dial:

1978H

where H is the hunting group number

(1 to 9)

For example, to put extensions 22, 23, 27 and 28 into hunting group number

1, dial

- 182223
- 19781
- 182728
- 19781

When a hunting group has been programmed, then dialling the directory number of the group (31 to 39) will ring the first free extension in the group. The exchange will hunt cyclically for a free telephone, starting from the one used the last time the group was dialled. This ensures that calls are distributed evenly around the group.

Dialling 19780 removes all extensions in the current programming range from any hunting group they are in.

3.7. SETTING RECEPTION PHONES

In addition to the ringing control codes described above, it is possible to control each extension's ringing by dialling a code from the extension itself:

602 + GS

This will reprogram the ringing for that extension, FOR WHICHEVER MODE THE EXCHANGE IS CURRENTLY IN (DAY OR NIGHT) ONLY.

For example, dialling:

6027

on extension 24 when the system is in night mode, will result extension 24 ringing when there is an incoming call on outside lines 1, 2 and 3, whenever the system is in night mode.

This can be cancelled by dialling:

6020

on the extension concerned.

This may be useful, for example, in routing incoming calls temporarily to a location other than the main receptionist's desk.

This facility is available to every extension in the system; however, it is not described in the extension users' hand book for security reasons. This means that the system controller is able to control which extensions know how to use this facility.

N.B. If an extension has been restricted from answering certain lines using the "61" code, the same restriction will apply when that extension is made a reception phone; so it will ring only for those lines that it is allowed to answer.

For example: If extension 23 has been set by dialling 19761, then dialling 6027 on extension 23 will make it a reception phone for line 1 only.

3.8. SUMMARY OF PROGRAMMING CODES

602 GS	Set ringing mode for this extension only (table below shows GS, group selection, values)
603 NN number	Set outside dialling memory number N
1920 hhmm	Set start of day mode
1921 hhmm	Set start of night mode
1951	Print out programming configuration
1952	Print contents of central dialling memories
1955 extn	Print contents of extension's dialling memories
1961 hhmm	Set time (hours 00-23; minutes 00-59)
1962 ddm	Set day (day 01-31; month 01-12)
1963 DAY	Set day of week (Monday = 1. . . Sunday = 7)
19650	Turn off call logging
19651	Turn on call logging
18 xxyy	Set extension (or outside line number) range for programming; xx = first extn, yy = last))

The following codes act only on extensions in the current programming range:

19430	Allow remote call answering for this extn
19431	Prohibit remote call answering for this extn
19440	Allow call interruption on this extn
19441	Prohibit call interruption on this extn
19740/19770	Program all calls allowed (day/night mode)
19741/19771	Program no international calls (day/night mode)
19742/19772	Program no long distance calls (day/night mode)
19743/19773	Program emergency calls only (day/night mode)
1976 GS	Program incoming call answering groups
1972 GS	Program extension ringing group (daytime)
1973 GS	Program extension ringing group (night time)
1975 GS	Program external dialling group
1978 H	Set hunting group (H = 1 to 9)

GS is a single digit value in the range 0 to 7, selected from the following table according to the required outside line group selection.

GS	Outside Line Group
0	No outside line
1	Line 1 only
2	Line 2 only
3	Lines 1, 2
4	Line 3 only
5	Lines 1, 3
6	Lines 2, 3
7	All lines - 1, 2 for a 2 + 10 system, 1, 2 + 3 for a 3 + 9 system

Issue 3
Feb 85

small systems engineering

**London 12 System Configuration And
Programming Record**

Customer _____ Installer _____
Site Address _____ Installation Date _____
Model No. SS12- - -
Serial No. _____

Exchange lines:

Line 1 Tel No. _____ Power fail extn 21
Line 2 Tel No. _____ Power fail extn 22
Line 3 Tel No. _____ Power fail extn 23

Extension Programming Configuration:

User/Location	Ext	Ring	Dial	Answer	Bar	Hunt	Divert	Attrib
	21							
	22							
	23							
	24							
	25							
	26							
	27							
	28							
	29							
	30							



small systems engineering

SECTION 4 USER GUIDE

CONTENTS

	Page
SECTION 4 : USER GUIDE	
Extension telephones	4.3
Making calls	4.4
Repeat last number	4.5
Alarm calls	4.5
Call pick up	4.6
Call hold	4.7
Call park	4.7
Enquiry calls	4.8
Transferring calls	4.8
Shuttle	4.9
Conference calls	4.9
Call diversion	4.10
Automatic callback	4.11
Charge account coding	4.12
Abbreviated dialling	4.13
RECEPTION TELEPHONE FACILITIES	
Incoming calls	4.14
Call waiting	4.14
Call interruption	4.15
Day/night mode	4.15
TONE DEMONSTRATION	4.16
ABBREVIATED DIALLING LISTS	4.17 - 20

EXTENSION TELEPHONES

Both LOOP DISCONNECT (pulse) and MF 4 (tone) telephones can be used on the London 12.

If you have an MF 4 telephone, you will have to use the Timed Break Recall button on the phone to obtain 'Recall' dial tone (see TONE DEMONSTRATION) before dialling digits to transfer a call or invoke a facility.

Throughout this book, the symbol 'R' means 'Press Timed Break Recall Button and Obtain Recall Dial Tone'.

If you have a loop disconnect phone, you can ignore the symbol 'R'.

MAKING CALLS

INTERNAL CALLS

Obtain dial tone and dial extension number

If the extension is busy, you will hear the engaged tone. This will change to a ringing tone when the extension you are calling becomes free.

Extension 21, normally the reception phone, may be called by dialling 0.

EXTERNAL CALLS

Dial 9

Wait for public dial tone

Dial the rest of the number

('Number unobtainable' tone means that you are barred from dialling that number. Your call barring in night mode may not be the same as it is in day mode.)

N.b Do not pause for more than 10 seconds between digits when dialling.

REPEAT LAST NUMBER | ALARM CALLS

REPEAT LAST NUMBER

To redial the last external number dialled from your extension:

Dial 5
Wait for public dialling tone
Dial 0

ALARM CALLS

To program your telephone to ring at a specified time:

Dial 606
followed by the time at which you want to be called
as a 4-digit number (24-hour format)
E.g. For an alarm call at 4.05p.m., dial 6061605

To cancel alarm calls:

Dial 607
(N.b. You can only have one alarm call programmed on your extension at one time.)

CALL PICK UP

EXTERNAL CALL PICK UP

If a reception phone is ringing for an outside call, to answer it from your non-ringing phone:

Dial 61

If there is no call to answer, you will hear dial tone.

INTERNAL CALL PICK UP

If any phone is ringing for an internal call, to answer it from your non-ringing phone:

Dial 65

followed by extension number of ringing phone

If the ringing phone is in your hunting group, to answer the internal call from your non-ringing phone:

Dial 62

If there is no call to answer, you will hear the Dialling tone.

(If you hear 'Number unobtainable' tone, you are not allowed to pick up the call.)

CALL HOLD | CALL PARK

CALL HOLD

To put an existing call (internal or external) on hold, so that the other party cannot hear you:

R
Dial 9

To return to the call:

R
Dial 8

CALL PARK

This allows you to hold an existing call and use your extension for making or receiving other calls.

To park a call in progress:

R
Dial 63

To retrieve a parked call:

Dial 64

If your phone is on-hook for 10 seconds without retrieving the parked call, the call will ring you back anyway.

ENQUIRY | TRANSFER

ENQUIRY

If you are on a call (internal or external), to speak to another extension:

R

Dial the required extension number

The original call is automatically put on hold.

To return to the original call:

R

Dial 8

TRANSFER

To transfer a call (internal or external) to another extension:

R

Dial the required extension number

Then either:

Hang up.		Wait for extension
Extension will ring	OR	to answer. Announce call.
Caller will hear ringing		Hang up. Call is automat-
tone. If the extension is		ically transferred.
unanswered after 30 sec-		
onds, the call (if an ex-		
ternal call) will automat-		
ically return to reception		
phones		

To recover a transferred external call if extension not answered:

Dial 691

To recover a call if enquiry extension does not wish you to transfer it:

R

Dial 8

SHUTTLE | CONFERENCE

SHUTTLE

At any point in an enquiry call, to return to the original call:

R
Dial 5

To return to the enquiry call:

R
Dial 7

(Enquiry extension does not hang up)

You may shuttle between the two calls as often as you wish. The other call will always be on hold.

CONFERENCE

1. External: To convert any outside call into a 3-way conference:

R
Dial the required extension number.
When the extension answers,
R
Dial 67

2. Internal: Any number of extensions can participate in an internal conference.

On an existing call, to bring a third extension into conference:

R
Dial required 3rd extension.
When the extension answers,
R
Dial 67

Further extensions may bring themselves into the conference by dialling 67 followed by the number of any of the extensions already in conference.

N.b. A conference call, once in progress, cannot be put on hold or transferred like a normal call.

CALL DIVERSION

CALL FORWARD

To divert all your calls to another extension from your own extension:

Dial 604
followed by the extension number
to which calls are to be diverted

You will hear a broken dial tone (see TONE DEMONSTRATION); anyone picking up your phone will hear broken dial tone until diversion is cancelled..

FOLLOW ME

To divert all your calls to another extension from that other extension:

Dial 694
followed by your own extension number

You will hear a dial tone; anyone picking up your phone will hear broken dial tone until the diversion is cancelled.

A broken dial tone is always heard in the phone which has been diverted; this does NOT mean that the extension is unavailable for making calls.

Only the phone to which your calls are diverted can ring your own extension. This means that they can pass calls back to you as required.

CANCELLING CALL DIVERSION

To cancel the diversion from your extension:

Dial 605

To cancel the diversion from any remote extension:

Dial 695

followed by your own extension number

If you do a second follow-me from another extension, the first diversion will automatically be cancelled and the second one implemented.

(If 'Number unobtainable' tone is heard after dialling 604 or 694, diversion to or from either or both of the extensions is barred).

AUTOMATIC RING BACK

(i) RING BACK WHEN FREE

If you dial an extension and get 'Busy' tone, to request a ring back, dial R 68 and hang up. When the extension becomes free, your phone will ring for 15 seconds. To 'trigger' the ring back, you must pick up your phone within this time; the extension you require will then ring.

(ii) RING BACK WHEN AVAILABLE

If you dial an extension and get ringing tone but no reply, to request a ring back, dial R 68 and hang up. When the extension you require is next used and the call is finished, your phone will ring for 15 seconds. Pick up your phone within this time; the extension you require will then ring.

To cancel outstanding ringbacks from extensions, dial 608.

(iii) RING BACK ON EXCHANGE LINES

If you dial 5 or 9 to get an outside line and get busy tone, to request a ringback, dial R 68 and hang up. When an outside line becomes free, your phone will ring for 15 seconds. Pick up your phone within this time; you will hear the public dial tone. You can dial the number you require without having to dial 9 again; similarly, if you dialled 5, you can dial the short code you require or 0 to repeat the last number dialled.

To cancel outstanding ringbacks on exchange lines, dial 698.

Up to 8 ringbacks may be queued on one target extension; they will be executed in order.

You may request any number of ringbacks on your extension; but they will not necessarily come back to you in the order in which you set them up.

All outstanding ringback requests are cancelled at midnight.

CHARGE ACCOUNT CODING

Any external call, incoming or outgoing, may be assigned to a particular charge account, which is coded using any three digits.

To assign a call:

R

Dial 4XXX

Where XXX is the designated account code.

On both incoming and outgoing calls, this should be done after the external party has hung up, before hanging up yourself. Wait for 10 seconds after dialling the digits before you hang up.

Alternatively, you may dial R 4XXX during the speech phase of the call; but in this case the call will be briefly interrupted.

When the call is finished, the account code will be printed as part of the call logging information.

ABBREVIATED DIALLING

CENTRAL MEMORY

The system controller can store up to 40 outside numbers in the central memory, to be used by any extension. These are coded 30 to 69.

To dial one of these numbers:

Dial 5

Wait for public dial tone

Dial code (30 to 69)

('Number unobtainable' tone means that you have dialled a barred code or an empty store.)

PERSONAL MEMORIES

You can store up to 9 external numbers, of up to 18 digits, for your extension. These are coded 11 to 19.

To store an outside number in memory:

Dial 603

followed by the chosen code (11 to 19)

followed by the outside number.

Wait for digits to be coded.

Hang up.

To store the last outside number dialled:

Dial 693

followed by the chosen code (11 to 19)

Wait for digits to be coded.

Hang up.

To dial a number from your store:

Dial 5

Wait for public dial tone.

Dial code (11 to 19)

OVERDIALLING

You can store part of the number in the memory of the system and the rest of the number after dialling the short code. E.g. If 01-538 is stored against code 11: to dial 01-538-2211, dial 5...112211.

RECEPTION TELEPHONE FACILITIES

INCOMING CALLS | CALLS WAITING

INCOMING CALLS

If your telephone is one that rings for incoming calls, then it is a Reception telephone.

If an incoming call remains unanswered for 40 seconds, then all extension telephones will ring.

When you receive an incoming call, you can use the Enquiry and Transfer facilities to process the call.

CALL WAITING

If an incoming call arrives when all reception phones are busy, a "Call Waiting" tone will be superimposed on the conversations in progress on all reception phones. (See TONE DEMONSTRATION).

To park the call that you are on in order to answer the incoming call:

R
Dial 61

To shuttle between the original call and the new call:

R
Dial 63

Alternatively, after transferring the second call to the required extension by hanging up, to retrieve the first call:

Dial 64

CALL INTERRUPTION | DAY/NIGHT MODE

CALL INTERRUPTION

Reception phones can interrupt a call in progress to pass on a message or an incoming call. A warning tone will be heard over the conversation while the reception phone is connected. (See TONE DEMONSTRATION).

To interrupt a call when you have dialled the extension number and obtained a busy tone:

R
Dial 66

You will then be connected to the extension you dialled and the third party.

To put an incoming call through to the extension you interrupted, ask them to park or terminate their present call and put their phone on-hook. Redial the extension to transfer the call in the usual manner.

To return to the incoming call if it is not to be put through to the extension that you interrupted:

R
Dial 8

OR, to shuttle back to the incoming call and terminate the intrusion:

R
Dial 5

This allows you to put your phone down to transfer the incoming caller to the (still busy) required extension.

(You may not be allowed to interrupt certain extensions, or conference calls.)

DAY/NIGHT MODE

To put the system into DAY mode:

Dial 600

To put the system into NIGHT mode:

Dial 601

The system can be programmed to switch automatically from one mode to another at the same times every day (See Programming Guide).

PHONE DEMONSTRATION

To listen to a demonstration of the tones used on the London 12 PABX, obtain the dialling tone and dial the appropriate code as follows:

Number Unobtainable tone.....	200
Ring tone.....	203
Busy tone.....	204
Interruption tone.....	205
Call Waiting tone.....	206
Alarm Call tone.....	207
Broken dial tone.....	208
Recall dial tone.....	209

RINGING

INTERNAL CALLS:

| ON | OFF | ON | OFF |

EXTERNAL CALLS:

| ON | ON | OFF | ON | ON | OFF |

RINGBACK CALLS:

| ON | OFF | ON | OFF |

ABBREVIATED DIALLING LISTS

PERSONAL MEMORY

Extn.....

NAME	ABBREVIATED CODE
	5 11
	5 12
	5 13
	5 14
	5 15
	5 16
	5 17
	5 18
	5 19

CENTRAL MEMORY

NAME	ABBREVIATED CODE
	5 30
	5 31
	5 32
	5 33
	5 34
	5 35
	5 36
	5 37
	5 38
	5 39
	5 40
	5 41
	5 42
	5 43
	5 44
	5 45

CENTRAL MEMORY, CONTD.

NAME	ABBREVIATED CODE
	5 46
	5 47
	5 48
	5 49
	5 50
	5 51
	5 52
	5 53
	5 54
	5 55
	5 56
	5 57
	5 58
	5 59
	5 60
	5 61

CENTRAL MEMORY CONTD.

NAME	ABBREVIATED CODE
	15 62
	15 63
	15 64
	15 65
	15 66
	15 67
	15 68
	15 69

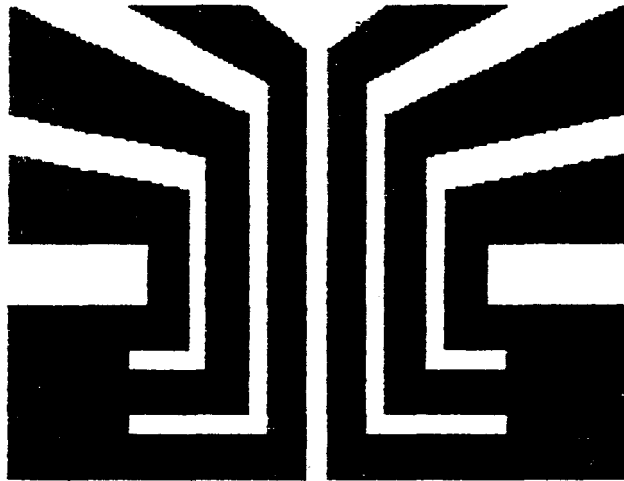

small systems engineering

SECTION 5 MAINTENANCE

CONTENTS

	Page
SECTION 5 : MAINTENANCE	
5.1 General	5.2
5.2 Tools required	5.2
5.3 Fault diagnosis and location	5.2
5.4 System in power fail mode	5.3
5.5 Extension faults	5.4
5.5.1 No dial tone	5.4
5.5.2 Unable to break dial tone	5.4
5.5.3 No ringing	5.4
5.6 Outside line faults	5.5
5.7 Printer / terminal faults	5.6

5.1 GENERAL

Present versions of the LONDON 12 are based on a single PCB design. On-site maintenance of the Central Control Unit is limited to the location of a fault to the Central Control Unit assembly and the renewal of that assembly. Faulty assemblies should be returned to the repair depot of Small Systems Engineering Ltd, showing clearly the nature of the fault.

Faults should be traced by using the following procedures.

5.2 TOOLS REQUIRED

The only special tools required for the maintenance of the LONDON 12 are the following:

ITEM	QTY
Krone IDC inserter tool	1
Krone Disconnection Plug (Krone part No. AF 0530)	6
Krone 4 Pole Plugset (see note below)	1
Multi Range meter	1
Loop disconnect test telephone	1
Multi-frequency test telephone	1

Note: To enable a test telephone to be plugged into the test jack on the Krone connection strip, a suitable plug (Krone part number AF0700 or AF0670) is needed. This can either be terminated directly on to the cord of the telephone (in the case of a Lineman's test telephone Tele 762 or similar) or via an adaptor made up from a short length of cord and a master line jack unit. Using the latter allows one of the customer's telephones to be used for testing. The plug should be terminated such that when inserted, the test telephone connects to the equipment side, with the line side disconnected.

5.3 FAULT DIAGNOSIS AND LOCATION

Prior to any attempt to locate a fault the user should be questioned about the nature of the fault and its symptoms. Whenever possible the user should be asked to demonstrate the fault. The maintenance engineer must be fully conversant with the system features and operating procedures, in order that he may advise the customer if necessary.

Using a printer or terminal, the programmed configuration of the system

should be examined in order to establish that the fault is not being caused by attempts to use a denied feature. The setting of the DIL switches should also be checked.

(Note: The DIL switches are read by the Processor on power up. Therefore if any changes are made to the switch settings, they will only become effective after the power has been removed then restored)

WARNING: THE CENTRAL CONTROL UNIT CONTAINS CMOS COMPONENTS WHICH ARE PRONE TO DAMAGE FROM STATIC ELECTRICITY. ANTI-STATIC PRECAUTIONS (SEE BS 5783) SHOULD BE TAKEN WHEN WORKING ON OR NEAR THE UNIT.

5.4 SYSTEM IN POWER FAIL MODE

The system will switch into its power fail mode (Exchange lines 1-3 connected directly to Extensions 21-23) if:

- a) The mains power is removed.
- b) The watchdog circuit fails to detect a signal from the processor and is subsequently unable to reset the processor. This implies a catastrophic failure.

Note: When the system is in its power fail mode the telephones connected to the power fail extensions must be of the loop disconnect type in order for them to be able to signal to the PSTN.

(i) Check the power-on LED on the Central Control Unit. If the system is in power fail with this LED on, the system should be manually reset by removing the power for approximately 10 seconds. If, on power up, the system does not respond or goes immediately into power fail, the Central Control Unit assembly should be renewed.

(ii) If the power-on LED is not on:

Check that mains voltage is present at the socket outlet.

Check that the 2A fuse in the 13amp plug is intact.

Check that the 1A 'Slo-Blo' fuse situated above the mains connector on the Central Control Unit is intact.

Unplug both ends of the mains lead and test for continuity of the the live and neutral conductors. (Note: earthing of the Central Control Unit is achieved by means of a separately run power protective earth wire. Therefore the earth conductor in the mains lead is redundant).

(iii) If the above checks reveal no fault and the mains supply is reaching the Central Control Unit, the assembly should be renewed.

5.5 EXTENSION FAULTS

5.5.1 NO DIAL TONE

(i) Check by substitution to ensure that the fault is not on the telephone instrument.

(ii) Check the voltage across the A and B wires of the extension socket. This should be between 45V and 48V.

(iii) Using a test telephone, check the extension port by plugging in to the test jack on the extension Krone connector. If no dial tone is received, the Central Control Unit assembly should be renewed.

(iv) If OK, the extension wiring and socket should be tested for possible disconnection or short circuit.

5.5.2 UNABLE TO BREAK DIAL TONE

(i) Check by substitution to ensure that the fault is not on the telephone instrument.

(ii) Check the voltage across the A and B wires of the extension socket. This should be between 45V and 48V.

(iii) Using a loop disconnect test telephone, test the extension port by plugging in to the test jack on the extension Krone connector. If unable to break dial tone, the Central Control Unit assembly should be renewed.

(iv) If OK, use a Multi Frequency test telephone and repeat (iii).

(v) If OK, the extension wiring and socket should be tested for possible low insulation resistance.

5.5.3 NO RINGING

(i) Check by substitution to ensure that the fault is not on the telephone instrument.

(ii) Ensure that no call diversion has been set up from the extension.

(iii) Using a test telephone plugged into the test jack on the extension Krone connector, set up an incoming call to the extension. If no ringing voltage is present (approximately 60V rms) the Central Control Unit assembly should be renewed.

(iv) If OK, the extension wiring and socket should be tested, paying particular attention to the socket, which contains the bell capacitor and resistor.

5.6 OUTSIDE LINE FAULTS

If an outside line fault is suspected, the following checks should be carried out:

(i) Plug a loop disconnect test telephone into the Krone test jack of an extension which has access to all outside lines.

(ii) Select each outside line in turn by dialling 81, 82, etc, and ensure that BT dial tone is received. Check seizure of the correct line by reference to LED 2 which lights when the line is looped, and flashes in time with the loop disconnect dial pulses.

(iii) Make an outgoing call on each outside line and check the quality of transmission. This will of necessity be only a subjective check.

(iv) If no dial tone is received on one of the lines, a loop disconnect telephone should be plugged in to the relevant test socket situated close to the Central Control Unit.

(v) If no dial tone is received, a disconnection plug should be inserted into the Krone test jack on the outside line connector, to ensure that dial tone is not being masked by a fault on the PABX.

(vi) If dial tone is still not received, the fault should be reported to BT.

(vii) If dial tone is received after inserting the disconnection plug, a fault on the Central Control Unit or test socket/wiring should be

suspected.

(viii) If the above checks prove OK, an incoming call should be made to each line in turn, and answered either at a Reception Phone or by using the 61 code.

Note: If the line under test forms part of an 'Auxiliary Hunting Group', all other lines in the group must be made busy so that the incoming call will arrive on the correct line.

(ix) If the Central Control Unit fails to detect an incoming call (ie the reception phone does not ring and LED 3 does not light up in time with the ring signal cadence), a telephone should be plugged in to the test socket of the line in question and an incoming call set up.

(x) If the telephone fails to ring, the fault should be reported to BT.

(xi) If the telephone rings OK but is still undetected by the PABX, a fault on the Central Control Unit should be suspected.

5.7 PRINTER / TERMINAL FAULTS

(i) Check that the printer/terminal is of the correct type, is connected to the mains supply and is plugged into the D-type socket on the side of the Central Control Unit.

(ii) Check by substitution to ensure that the fault is not on the printer/terminal.

(iii) Check to make sure that the fuses on the printer port fuse disconnection barrier are intact.

(iv) Check that the system has been programmed for a Baud rate matching that of the printer/terminal.

(v) Check continuity of the lead connecting the printer/terminal to the Central Control Unit. The following pins are used:

PIN	SIGNAL
3	Transmitted data
7	Signal ground
20	Data terminal ready (DTR)

(vi) If the above checks prove OK, The Central Control Unit assembly should be renewed.